

# ELECTRIC PUMP WEDA L100

---

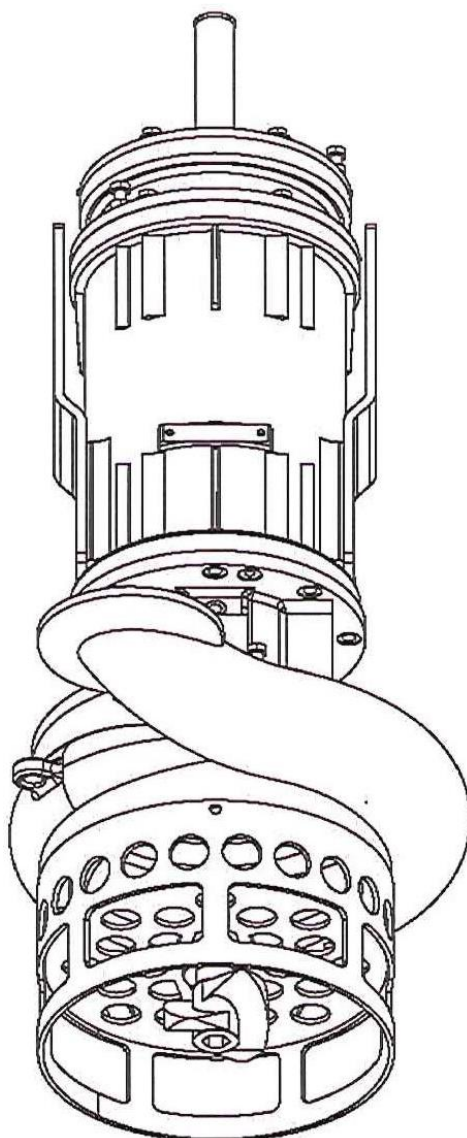

Instructions handbook



*Atlas Copco*



## INDEX

PRESENTATION.....	pg. 3
WARRANTY REGULATIONS.....	pg. 4
1.0 DESCRIPTION.....	pg. 5
2.0 TRANSPORT, ASSEMBLY AND DEMOLITION.....	pg. 6
3.0 STARTING AND OPERATION.....	pg. 12
4.0 MAINTENANCE AND CLEANING.....	pg. 14
5.0 NOISE.....	pg. 18
6.0 SAFETY.....	pg. 19

## PRESENTATION

This instructions manual has been conceived and structured for rapid and easy consultation, thanks to the index ordered by subjects, and explanatory figures and tables.

## GENERAL WARNINGS

This instructions manual must be studied by the owner of the machine, the technical personnel within the factory, the operators, that is, all those that will be using the machine, the maintenance technician. The manual is an integral part of the machine and contains information on its use, technical characteristics, as well as instructions for handling, installation, assembling, regulation and maintenance. It also contains a section for trouble-shooting, if necessary, and for the ordering of spares. The **Atlas Copco** technicians are always available, by telephone, fax or e-mail, to supply all the explanations that may be needed.

### This manual:

- must be considered as integral part of the machine until it is taken to the breakdown yard;
- must be kept in an easily accessible place and suitable for its preservation;
- must be consulted each time that there are problems or doubts on the operation of the machine;
- must be carefully followed for whatever regards the necessary maintenance operations set out in it.

In case it is lost, apply for a copy directly from **Atlas Copco**.

**Atlas Copco** reserves the right to carry out all modifications to update the machine or instructions manual according to the technological progress and the state of the art.

This constitutes no obligation to carry out modifications to the machines that have already been sold. If the machine is ceded to a third party, it is recommended that of the instructions manual follow it.

### ATLAS COPCO RETAINS ITSELF FREE FROM LIABILITY OF ANY KIND, AND ESPECIALLY FOR:

- improper use of the machine;
- use of the machine by personnel not trained to use it;
- power supply defects;
- maintenance defects;
- unauthorized and unforeseen modifications;
- use of spares that are not original or not specific for the model;
- non observance of the instructions;

The uses of the machine for different purposes are to be considered dangerous for the operator and for the machine. Likewise, modalities of installation and utilizations different from that indicated in the present manual could cause damage to persons and/or to the machine itself.

## WARRANTY REGULATIONS

**Atlas Copco** guarantees the original user that the machine will be reasonably free from factory and material defects.

This warranty lasts for 12 ( twelve ) months from the invoice date, and refers to the repairing of any defect that will be recognized by **Atlas Copco** as being subject to warranty.

The warranty does not apply to those parts that result defective because of incorrect use, handling or bad observance of the use and maintenance instructions supplied by **Atlas Copco**.

The warranty is not applied for those listed parts subject to normal wearing:

- *seals and gaskets, shaft sleeves, impeller, stirrer, wear-plates, casing, discharge adapter, excavator teeth and electrical components;*

The warranty on the electric motor is applied only if the *standard electronic control console* foreseen has been installed.

If the Purchaser tries, either to repair any fault that is under guarantee, or obtain direct supply of the spare part without previous written consent of **Atlas Copco** the latter will not be responsible for the results of the repair and will not be held to reimburse the expenses sustained by the Purchaser.

Any claim for warrantable failures shall be sent in writing to **Atlas Copco** prior to the expiry of the warranty period.

As soon as the spare is ready, the Client will make the defective part available to **Atlas Copco**.

The warranty is applied in one of the following ways and at the discretion of **Atlas Copco**:

- replacement of defective part with a new one, made available in the offices of the Purchaser at the lowest transport rate;
- repair of defective part, after this has been returned to **Atlas Copco** with transport expenses prepaid.

**Atlas Copco** declines all responsibility for the expenses due to “down-time”, business costs and losses deriving there from.

This warranty is the sole warranty provided by **Atlas Copco**.

There are no other warranties, explicit or implied, or of merchantability or fitness for a particular purpose.

## 1.0 DESCRIPTION

### STRUCTURAL DESCRIPTION OF THE MACHINE (Fig. 1)

The Dragflow motor driven pumps are made of high quality materials and undergo severe controls before leaving the factory.

They are essentially made up of a cylindrical pump casing **3** inside of which is housed an electrical motor **4**. The upper part **2** is completely water-tight, and contains the terminal box for connection to the electric motor, the seal is guaranteed by the cover **1** and by a series of seals.

Inside the oil housing **5** is housed the group of seals and gaskets **11** that prevents the water from passing to the motor.

On the main shaft **12**, inside the casing **6** there is a keyed impeller **7**, made in high chrome content anti-wear materials.

A wear plate **8**, made with the same material, partially closes the impeller inlet.

Inside the strainer protection **9** houses a cutter **10** that rotates and stirs the mixture of solids in the water to be pumped.

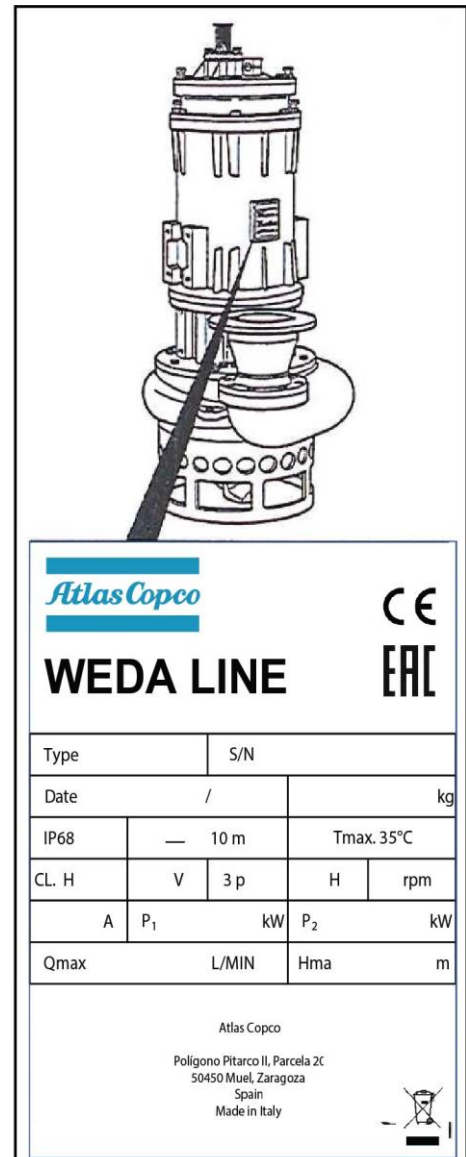
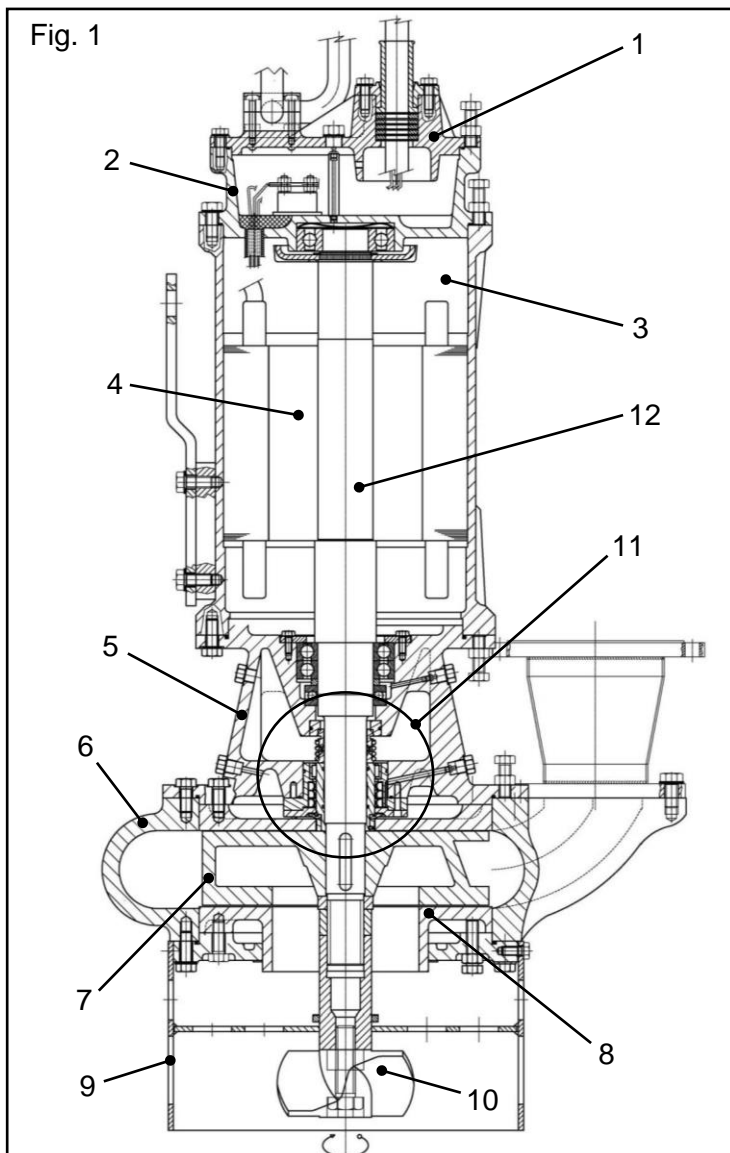

## 2.0 TRANSPORT, ASSEMBLY AND DEMOLITION

Dragflow pumps are generally transported encased inside a crate to avoid damage to the pump or parts of it. The crate is arranged for unloading with a fork-lift truck, whose capacity must be able to sustain the weight of the pump ( see data sheet enclosed in this instructions handbook ) as shown in **Fig. 2**.

The pump is placed inside the crate as seen in **Fig. 3**, it must be freed from the packing and lifted with ropes hooked to the appropriate lifting plate **A**.

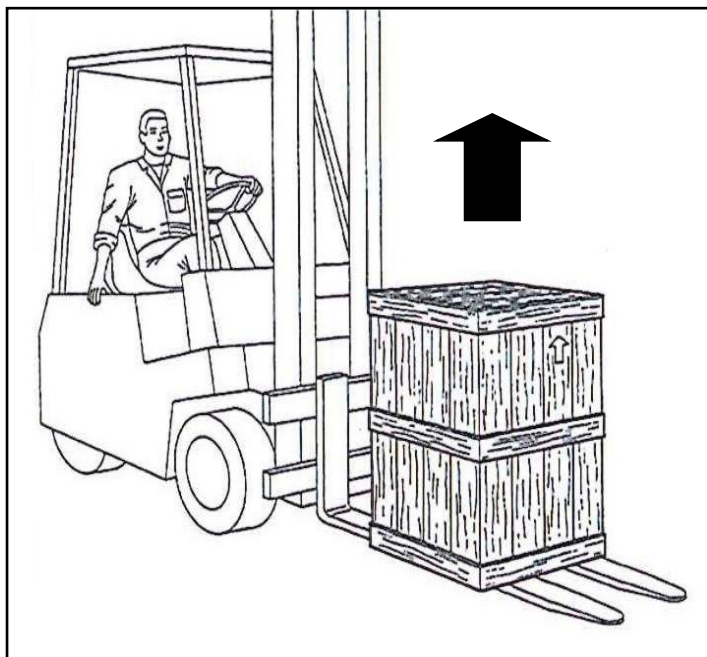

Fig. 2

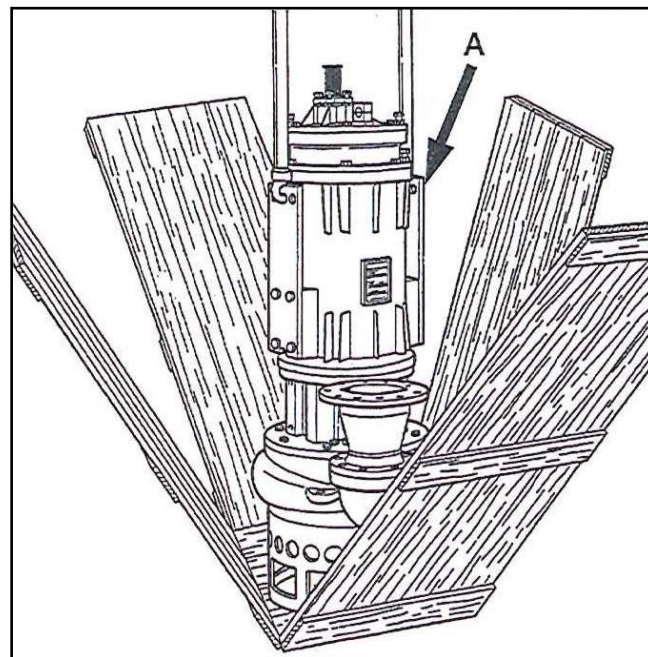

Fig. 3

### INSTALLATION

**1) Connect the delivery pipe.**

- The delivery pipes must never form siphons (**Fig. 5**) pag. 6, to avoid problems due to the formation of air pockets or deposits of solid material.
- Before connecting then pump to the electrical supply source, make sure that all the data on the rating plate correspond ( voltage, power, absorption, etc. )

The pump is supplied with a supply cable already connected.

**2) Connect the end of the wires to the control panel, taking care to respect the power supply phases and the yellow/green ground wire that will be connected to the general grounding system of the plant.**

- The user must guarantee the electrical conductivity between the machine and the main grounding system of the plant.

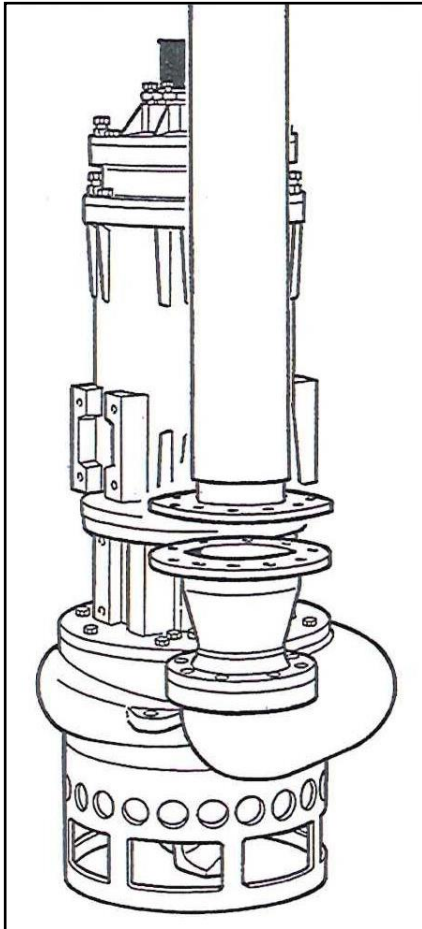

Fig. 4

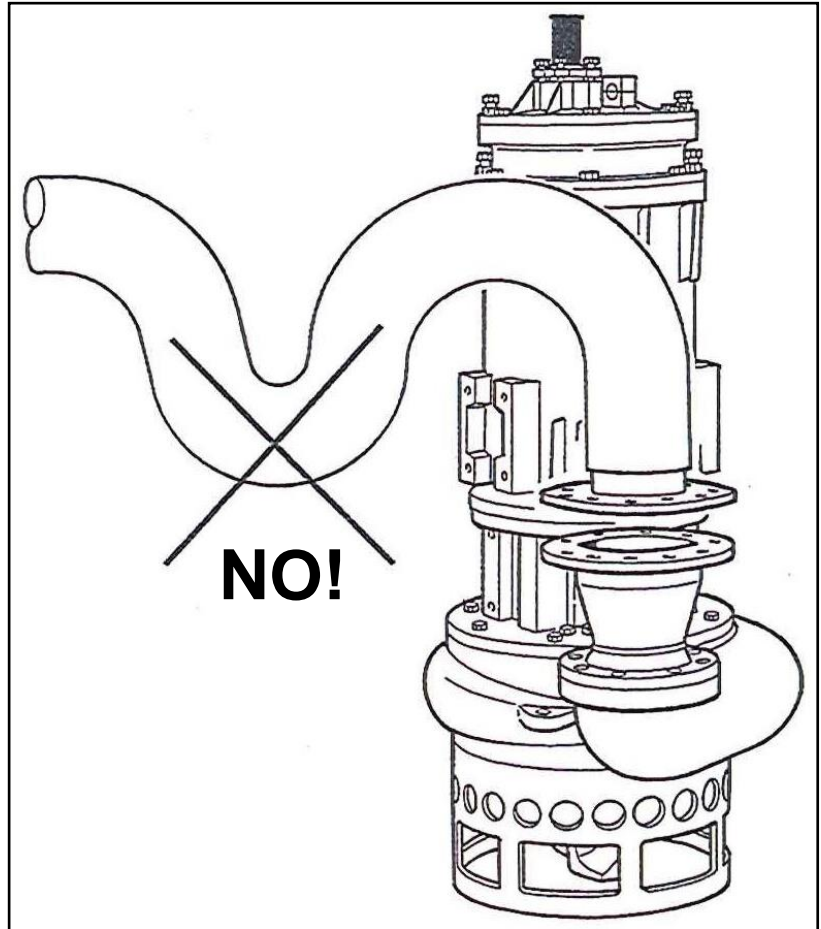

Fig. 5



3) If the electric cable has not been requested proceed as follow (**Fig. 6b**) pag. 8:

**Warning:** the pump supply cable must be a cable HO7RN-F type with rubber insulated flexible wires, chloroprene-type 076 internal sheath in compliance with CEI 20-19- mark HAR with a cross-section for the current absorption of the pump, or of equivalent type.

- Be sure to disconnect the electrical supply.
- Loosen the screws **4** and their washers **5**, then remove the cable gland **1**.
- Loosen the upper bolts **6** with its bonded seal **7** and lift the stuffing box **77**.
- Fix on the electric cable **87** the following items in the same sequence as written (**see Fig.6b**): the cable gland **1**, rubber sleeve **2A** (n.1) passing it inside the cable gland internally (**Fig.6a**), the steel washers **2B** (n.6), the rubber washers **2C** (n.5), steel and rubber washers must be fit alternately.
- Insert this prepared electric cable into the stuffing box **77**, *be carefully the cable wires must be long enough to reach the terminal box **85** inside the electric motor cover **75**.*
- Compress the kit **2A,2B** and **2C** to pack the washers together by tightening the screws **4** of the cable gland **1** to prevent any water seepage inside (use the torque table for tightening the screws).
- Rotate the stuffing box **77** upside down and fix the plastic spacer **3D** making the wires passing through the prepared 4 (four) holes (**Fig.6c, pg.9**).
- Use a knife or scissors and carefully remove the wires rubber cover inside the prepared resin basin of the stuffing box **77** (**Fig.6c**) for about *0,5 cm length*. This has to be done between the 2 (two) spacer **3D** and **3E** (**Fig.6a**) to avoid the water can seep in through the wires in case of electric cable cut.
- Place the second plastic spacer **3E**, the wires have to pass through the 4 (four) prepared smaller holes as indicated in **Fig.6d, pg.9**
- Screw in the 3 (three) bolts **3A** inside the resin basin and fix the yellow/green ground wire to one of them provided screw (**Fig.6e, pg.9**).
- Fill completely with the epoxy resin **95B** the resin basin through the external holes of the spacer **3E** (**Fig.6e**) (top up little by little to avoid the epoxy resin has a crack during its hardening).
- Connect the three phases wires to the terminal box **85** using the terminals **3H** and the nuts **3C** (**Fig.6b**).
- Place the stuffing box **77** on the electric motor cover **75** making sure that the o-ring **76** is new and remains in its seat, to avoid damage and as a result water leakage, tighten down the screws **6** with the bonded seal **7** (**Fig.6b**).
- Connect the other end of the cable as shown in the wiring diagram.

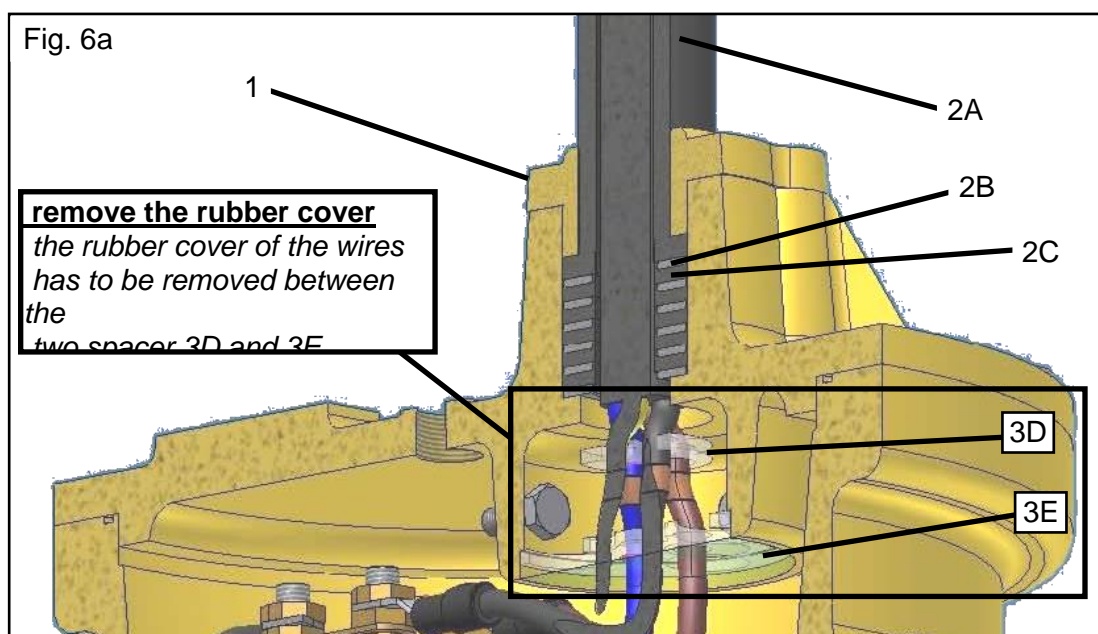

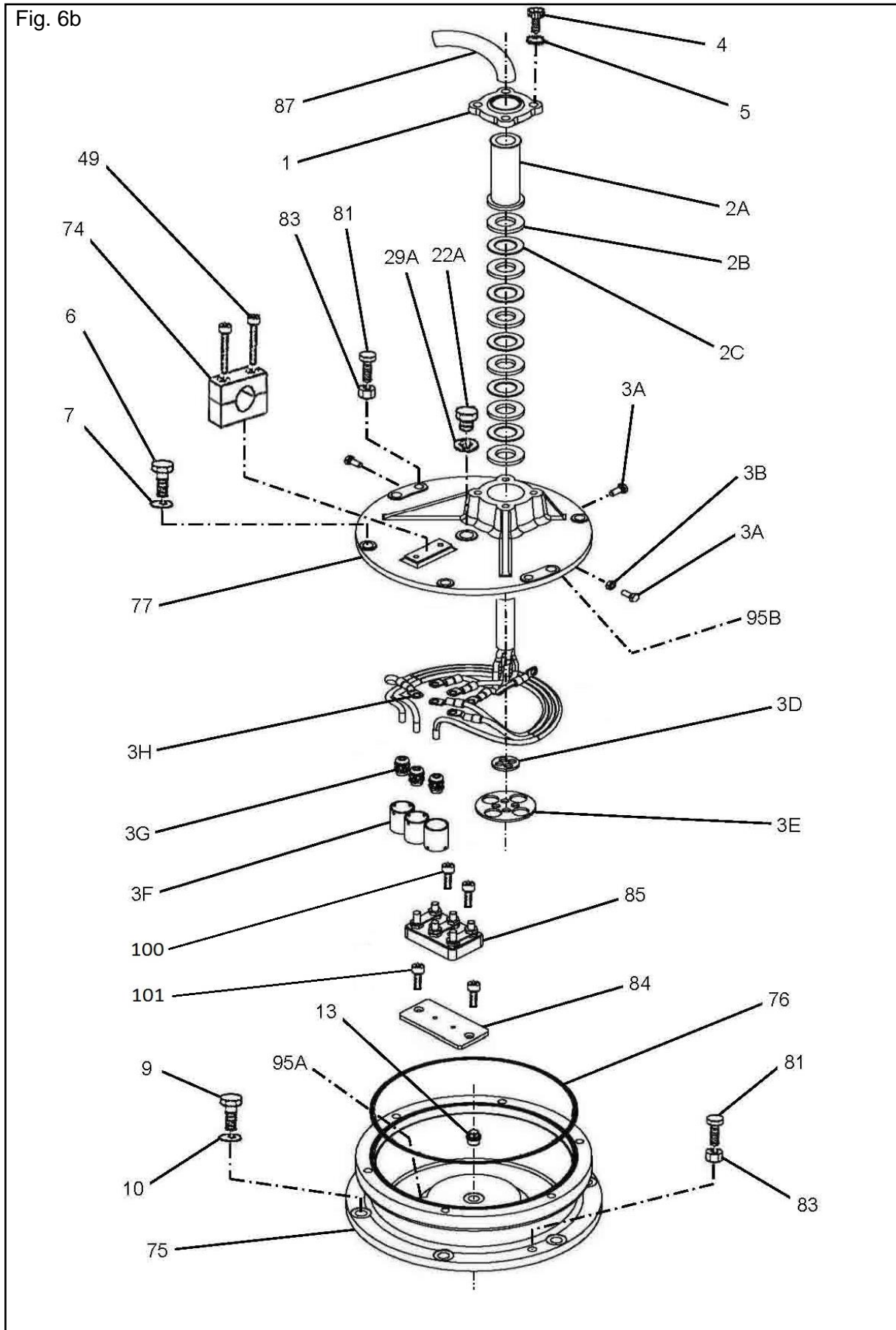

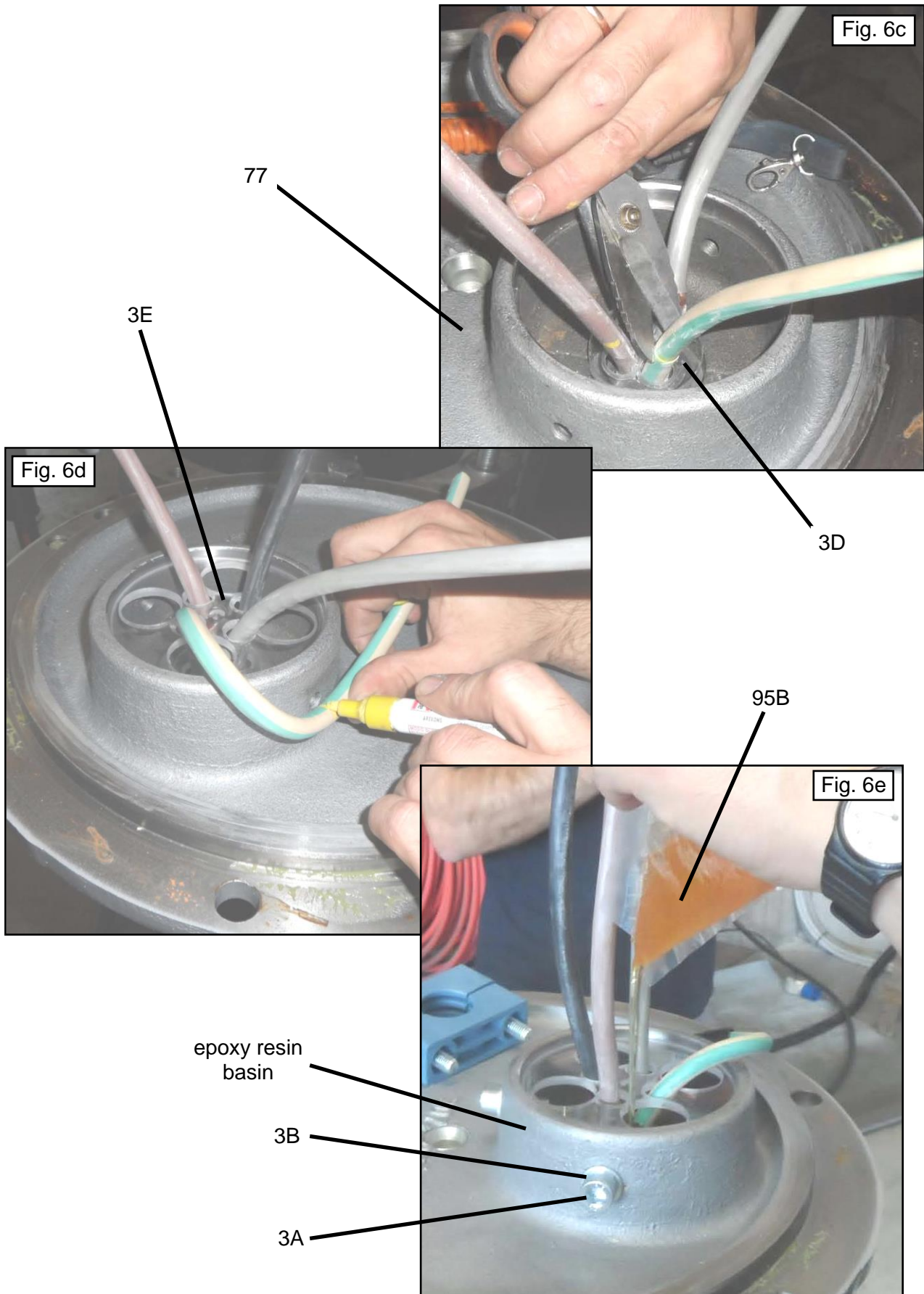

## **DISMANTLING**

Before doing anything on the pump, be sure to disconnect the electrical supply and disconnect the delivery pipes.

**Warning:** the machine that is considered completely useless must be removed from the department and collected by the manufacturer or any other firm specialized in demolition. Remember that dismantling the machine in your establishment will “produce” different materials ( metals, plastics, oil, etc. ) whose disposal will be done in compliance with the legislative regulations in force in the state where the machine is found.

### 3.0 STARTING AND OPERATION

#### STARTING

The pump has been created to pump suspended matter, even with solid parts, as long as water is always present. It can be used for civil and industrial purposes, as long as conditions described in this manual are observed.



#### ATTENTION

1) The control panel has a switch to which must be applied a device with a lock that stops the use of the pump. The key will be given to someone in charge who will be responsible for all the operations which he will supervise to avoid improper use of the machine.

Check the direction of rotation: by passing very short current impulses with the START/STOP switches placed on the control panel, and check that the direction of rotation is that indicated on the rating plate.

- 2) Immerse the pump in clear water and push the "START" button.
- 3) If any priming problems should come up, stop the pump by pressing the "STOP" button and wait for about 30 seconds, leaving it immersed, until all the air has been eliminated.
- 4) Never operate the immersed pump without connecting the pipes, because not sensing the load loss foreseen, the electric motor could overshoot the maximum current absorption (and in the absence of the suitable safety devices be completely damaged). When only water is pumped, absorption should be 20% below that allowed.

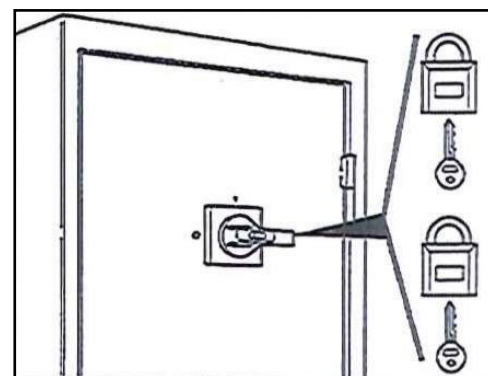

If this is not the case, the load loss must be increased, in one of the following ways:

- by adding pipes
  - by creating bottlenecks
  - raising the discharge height
- 5) Slowly lower the pump until it comes into contact with the material.
  - 6) Check the percentage of solid in order not to go over the maximum absorption limit.
  - 7) When clean water is not available, but only mud and other mixtures, check that the pump does not go over the maximum absorption limit indicated on the rating plate (**Fig. 7**); however, if this does happen, create a further load loss, acting as indicated at the preceding point 4.
  - 8) Before stopping the pump, it is always a good rule to pump water with very little solid in it, so that the pipes are washed.

## WEDA LINE

Type		S/N			
Date		/		kg	
IP68	—	10 m	Tmax. 35°C		
CL. H	V	3 p	H	rpm	
	A	P <sub>1</sub>	kW	P <sub>2</sub>	kW
Q <sub>max</sub>	L/MIN		H <sub>ma</sub>	m	

Atlas Copco

Poligono Pitarco II, Parcela 2C  
50450 Muel, Zaragoza  
Spain  
Made in Italy

VOLTAGE

AMPS

Fig. 7

## **EMERGENCY SITUATIONS**

The correct use of the machine excludes the possibility of emergencies happening during operation or during cleaning and maintenance, unless the latter have not been done in compliance with this instructions manual.

- a) In case of imminent danger of a mechanical origin, press, or have someone press, the emergency stop button, and immediately afterwards switch off the general cutout switch or disconnect the plug. An accurate search for the fault, or anomaly that caused the danger, must be carried out soon afterwards, and once detected, see to resetting the operation of the machine and of the protection set-up. If necessary, have **Atlas Copco** Service or competent personnel from another firm carry out any repairs or work.
- b) If a current loss should be found, felt by touching metallic parts of the machine, switch off the general cutout switch and have an expert electrical technician come in, or contact **Atlas Copco** Service for further details.

## 4.0 MAINTENANCE AND CLEANING

**Warning:** maintenance and cleaning of the machine must be done after having stopped the machine.

- 1) Check the tightness of the fastening screws every 50 hours of pump operation.
- 2) Remove the lower plug marked by the label GREASE , **Fig. 8**, and restore the grease with 50 grams of it into the seals zone using a hand grease gun. **Seals zone must be greased every 8 hours.**  
The upper plug marked GREASE lubricates the bearings zone of the oil chamber, **this zone has to be greased every 150 hours with no more than 50 grams (Fig.8)**, with a higher quantity or more frequent greasing the upper mechanical seal of the pump could be damaged.  
**Use water resistant grease with LIQUILON.**
- 3) **Every 150 hours** check the clearance between the impeller **47** and the lower wear plate **48** is as follows (see **Fig. 9**).
  - keep the pump in a vertical position;
  - dismantle the side strainer **53** by removing the screws in position **21**;
  - check that the clearance is not more than 1,5 mm, if it is wider proceed as follows:
  - slacken of the fastening screws **52**;
  - take the wear plate **48** at a distance of about 1,5 mm from the impeller **47**, by turning the adjustment screws **81** and locknuts **83**;
  - check that it rotates freely;
  - fasten both the locknuts **83**, the adjustment screws **81** and the fastening screws **52**;
  - fit again the strainer **53** using the screws **21**;
 (Use the torque table for tightening the screws).

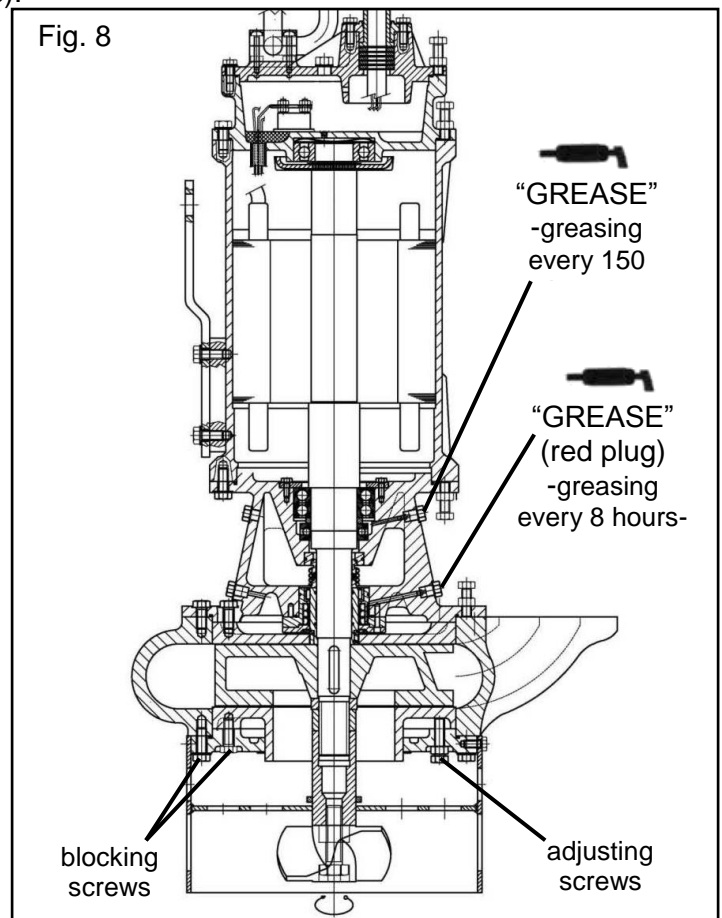
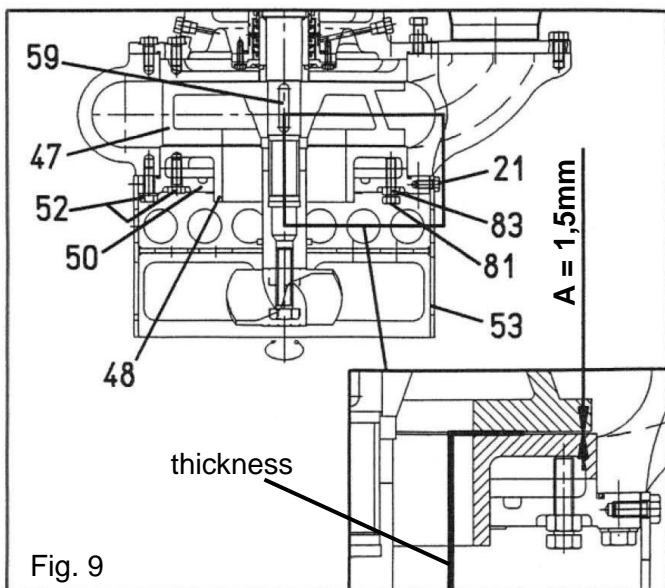

- 4) For customers that work with particularly abrasive materials having a very fine particle size, we advise passing a jet of water under pressure, connecting it to the prepared threaded connector indicated with H<sub>2</sub>O (Fig. 10). The pressure must be greater than that exerted by the pump to have continuous cleaning of the area of the seals and so less wear.

**It is compulsory to grease the area of the seals at the end of each shift or every 8 working hours, use water resistant grease with LIQUILON.**

- 5) Check the level and the deterioration of the oil every 8 hours of operation by removing the plug labelled "OIL" (Fig. 11). For a total oil change or topping up, the following steps have to be taken:
- a) It is good practice to empty the pump completely of the remaining oil. The exhausted lubricant must be disposed of in conformity with the laws in force in the country where the machine is used, since its dispersal in the ground will pollute the water beds. This is not necessary if the oil is simply topped up.

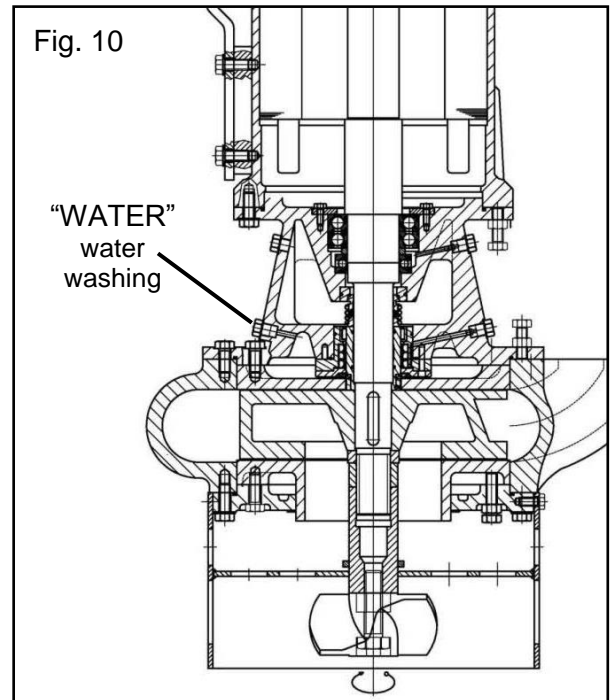

- b) Remove the plug marked "OIL".
- c) Top up until completely full using a funnel on side up to the indicated "OIL LEVEL" (Fig. 11), approx 5 Kg of oil having the characteristics as in the table following.

Oil type	ISO	Viscosity Cst 40°C	Viscosity Cst 100°C	Density kg/m <sup>3</sup>
S32	32	32	5,4	857

- d) Before closing the plug change the copper washer to prevent leaks and water seeping in. If the oil is "milky" white color the seals must be replaced.

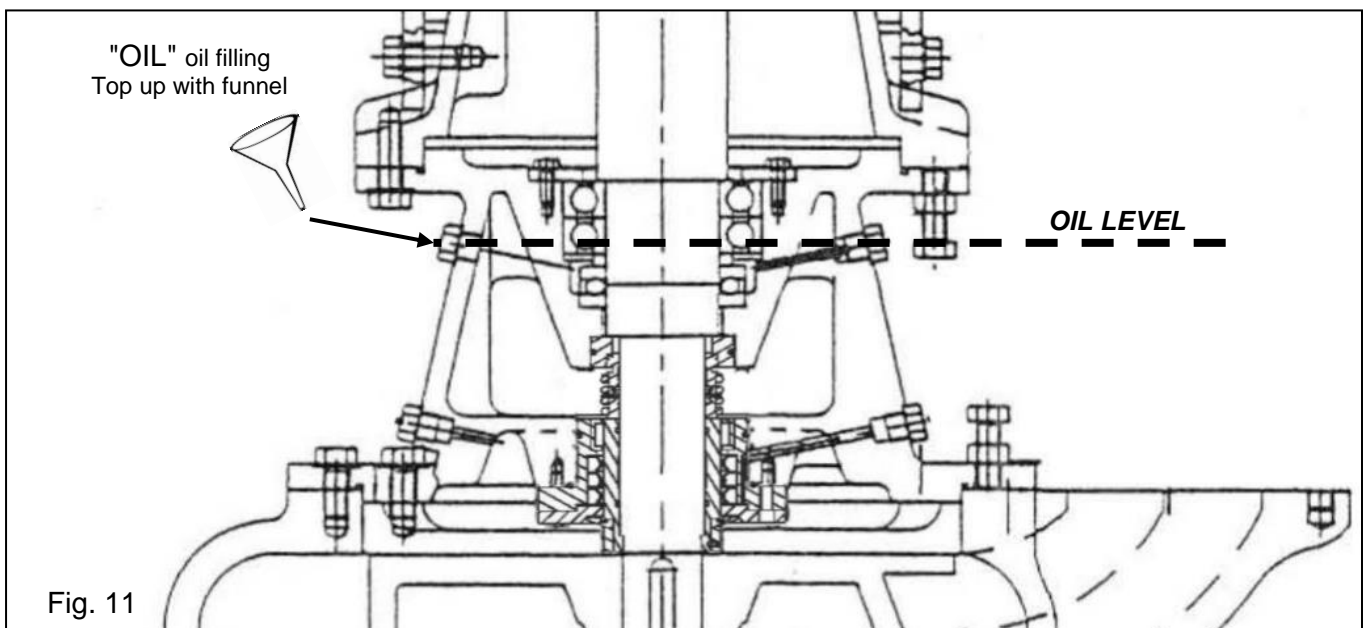



**REPLACING THE SEALS**

- Completely empty the oil from the oil chamber.
- Remove the filter **53** (Fig. 12) by unscrewing the screws **21**.
- Unscrew the cutter **54** by hitting it smartly in an anticlockwise direction as shown in Fig. 13; make sure the impeller **47** (Fig. 12) is blocked with an iron rod.
- Remove the connection **56** (Fig. 12a), then the nut **57** and the spacer **58**.
- Extract the flange on the suction side **50** (Fig. 12) after having removed the screws **52**. With the flange pos. **50** the lower wear plate **48** also will come down.
- Remove the casing **45** (Fig. 12) after having removed the screws **42**.
- Extract the impeller **47** using two levers "A" (Fig. 12). If it sticks use an extractor, taking care not to damage the threaded part of the motor shaft.
- Remove the key **59** and slacken the screws **42a** (Fig. 12) to let the upper wear plate **46** coming down.
- Unscrew the grub screws **25** to release the spacer **20** and then the seal **66** (Fig. 14, pg.16). Remove the seals housing **67** and **65** (Fig. 14) after having removed the screws **78**.
- Extract the shaft sleeve **31** and the mechanical seal **93**. **Clean carefully the shaft and all the housings and take care not to damage any spare parts (follow Fig. 14).**
- Change the mechanical seal **93** (n°1).
- Change the seals **36** (n°1), **41** (n°2) and the two o-rings "OR" **23** (n°1) and **26** (n°1) of the seals housing **67**.
- Change the lower shaft sleeve **31** and its o-rings **28** (n°2).
- Fix back on the lower sleeve **31** and the seals housing **67**.
- Place the seal **66** as shown in Fig. 14 and lock it inside using the spacer **20**.
- Do not forget to screw in the grub screws **25**.

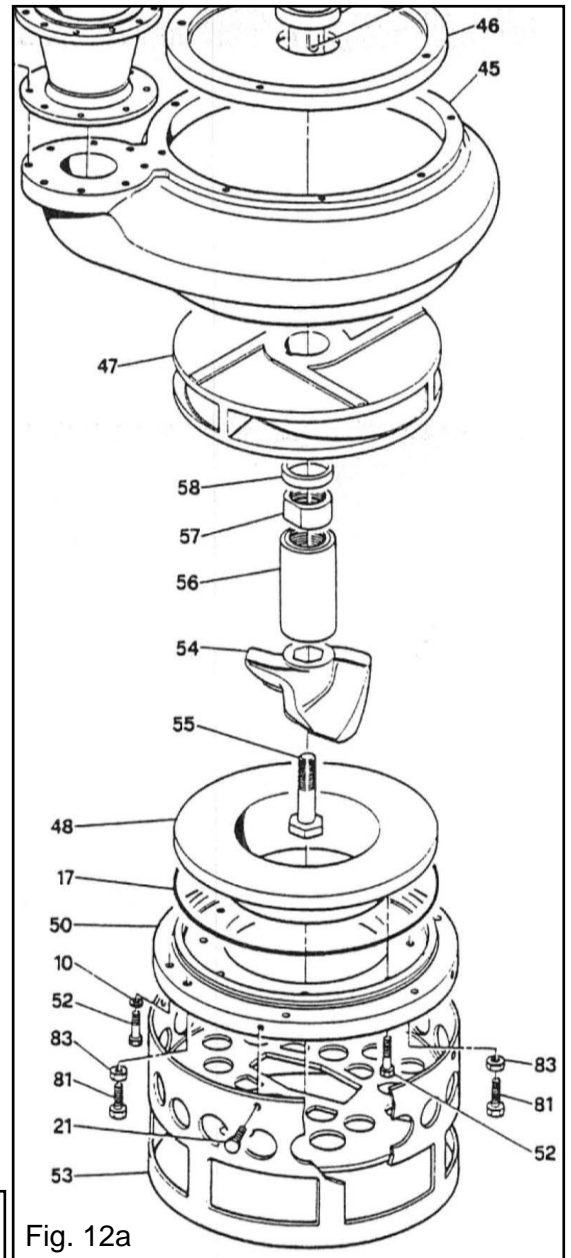

Fig. 12a

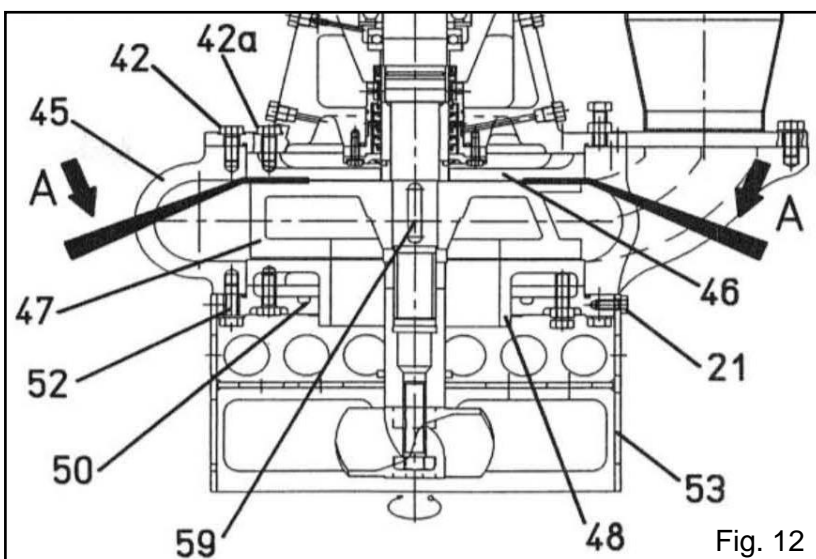

Fig. 12

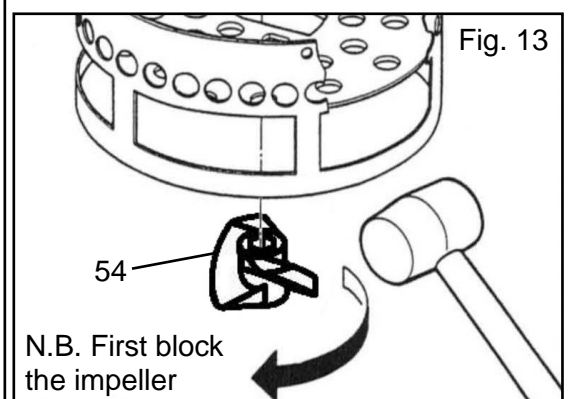
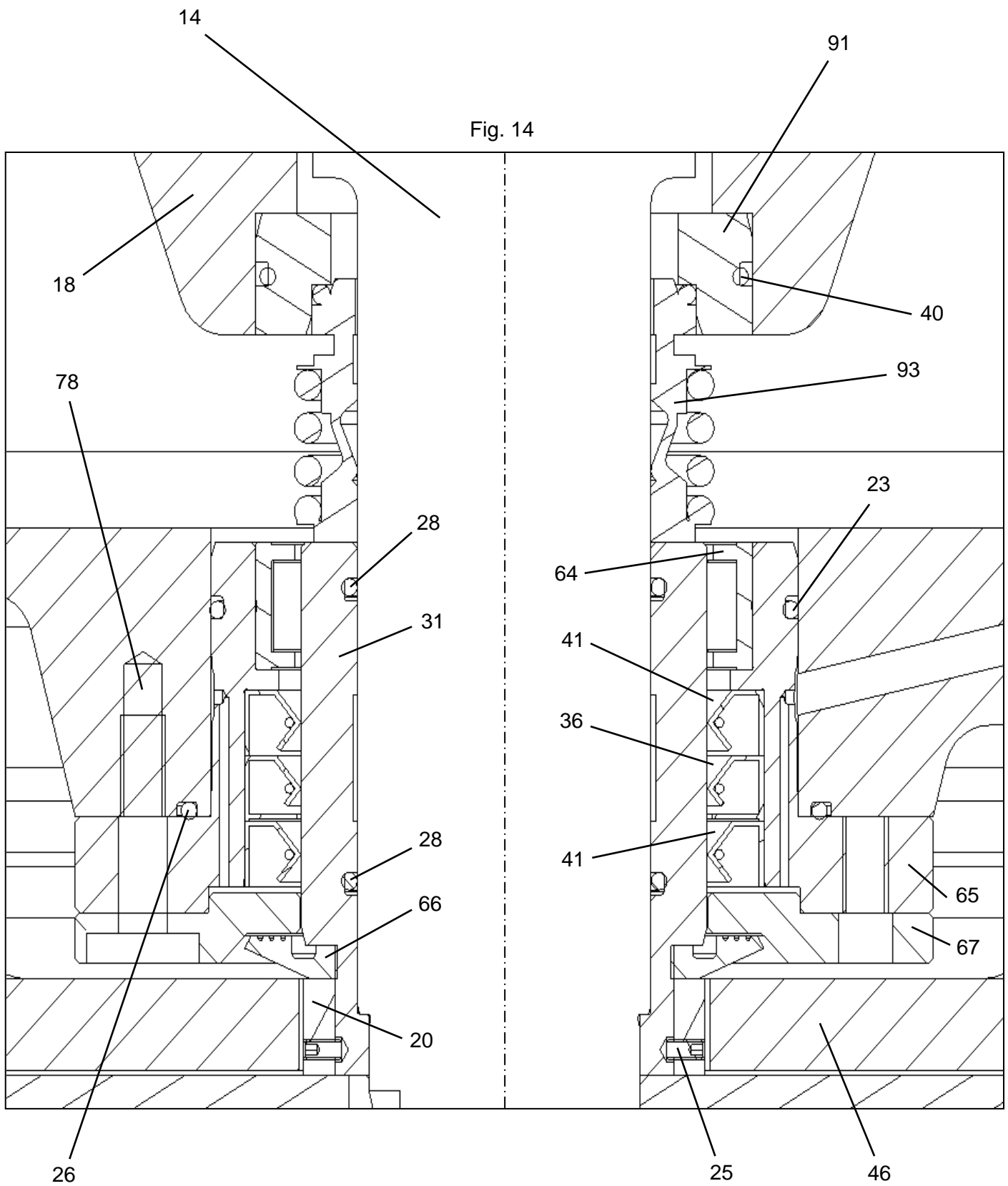

Fig. 13

N.B. First block the impeller

Fig. 14



- To reassemble follow the instructions in the reverse order **keeping the pump in vertical position**. Remember to adjust the lower wear plate **48 (Fig. 9 pag. 13)** before closing the pump definitely. Top up with new oil, according to the instructions of paragraph **5) pag. 14**.

**Once a year, each time that repairs have been carried out, when extraordinary events have occurred, the user must check the state of the electrical, insulation and the continuity of the protection circuit.**

**When parts of the electrical equipment are replaced, components with electrical characteristics as similar as possible to the originals must be used.**

**The supply cable MUST be replaced as soon as damage to the external insulation is found.**

### **PUTTING THE MACHINE OUT OF SERVICE**

If for any reason whatsoever the machine should be temporarily placed out of service, it is important to disconnect the electricity supply, clean it and cover it to protect it from dust.

To put it back into service again follow the instructions for starting up.

## **5.0 NOISE**

The machine was designed and manufactured while at the same time keeping in due consideration air noise hazards. The construction techniques used allow to limit the noise level within tolerable limits in compliance with the Machine Directive 2006/42/CE.

Air noise detection was effected by placing the probe two meters from the machine, along the whole perimeter and at a meter from the floor. The noise was measured under vacuum. This because the machine itself does not require any specific operation position fixed by the operator since it is normally immersed in water and therefore the values are non-influencing.

The observations were done with a model HD9020K1 DELTA OHM PRECISION INTEGRATOR NOISE METER in conformity with the:

- IEC651 class 1 standard
- IEC804 class 1
- IEC225 filters 1/3 octave

The instrument was calibrated with a DELTA OHM HH9101 calibrator conforming to the IEC942-1986 class 1.

## 6.0 SAFETY

### Introduction

Atlas Copco has designed and built the machine keeping in mind the results of a preventive and accurate analysis of the risks connected to the use of the machine.

The protections and devices applied, therefore, represent the profuse commitment by the Atlas Copco technicians to achieve the aim of safety sanctioned by the specific directives issued by the EEC. The protections and devices are illustrated below with drawings.

Other instructions and information on the safety of the machine are contained in the paragraphs which deal with the use, maintenance and repair.

All the organs in movement are segregated inside the pump structure.

The only rotating mechanical part is the agitator 54 ( Fig. 16 ), that for functional reasons cannot be protected in any way.

In fact its specific function is that of cleaning the strainer 53 and stirring the solid bodies present in order to set them in suspension in the liquid to be pumped ( Fig. 16 ).

On the pump there is a warning plate ( Fig. 15 ) to remind us of this danger.



**When about to operate the pump, keep clear of this rotating part in order to avoid accidents.**

The strainer 53 ( Fig. 16 ) is made according to the suction capacity of the pump, and does not allow the passage of particles of over 60 mm diameter.

It is a good rule not to come close to the pump when it is immersed in water to avoid dangerous situations.



**Do not open without having first switched off.**

On the pump there is a warning plate to remind us of this danger ( Fig. 15 ). The upper part of the pump contains the electrical terminal box of the motor.



Fig. 15

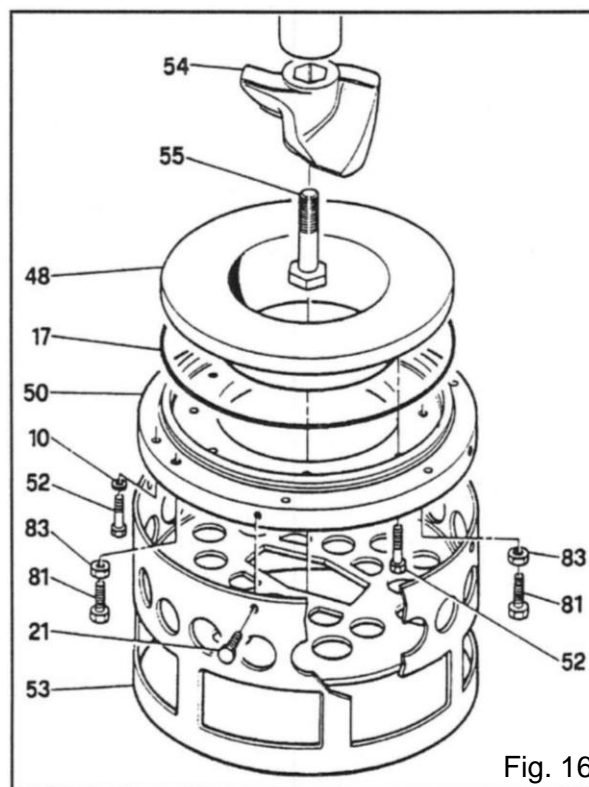

Fig. 16

It is protected in a sealed chamber by means of a series of seals, that avoid water leakage.  
The rated voltage present is that expressed on the rating plate ( **Fig. 17** ).

When starting check:

- the correct connection of the phases;
- the correct direction of rotation of the motor;

The direction of rotation is expressed on the rating plate ( **Fig. 17** ).

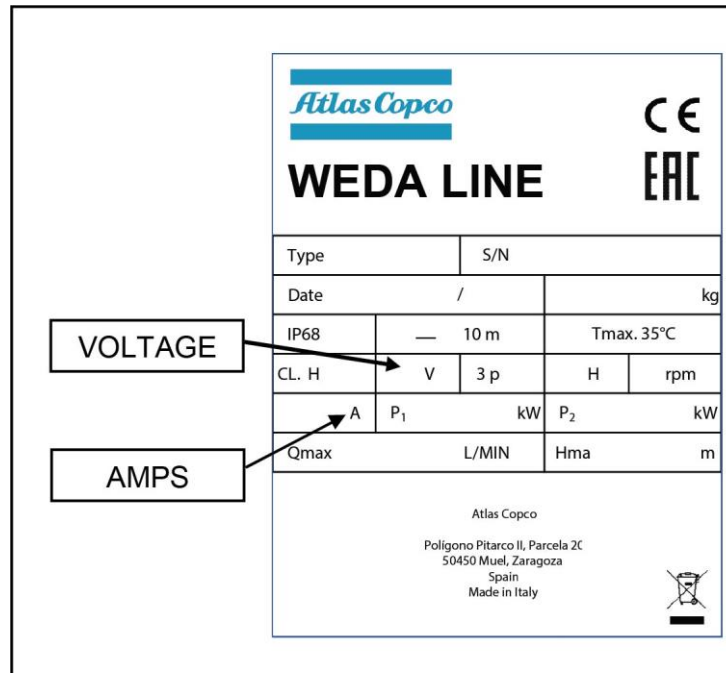

Fig. 17

### **INDIRECT CONTACT PROTECTION**

All the metal masses are grounded with a yellow/green wire.

The user **MUST GUARANTEE** the electrical conductivity between the machine and the main grounding system of the plant.

- The machine has an overall protection rating of IP68.
- The electrical tests carried out on the machine, in conformity with what is provided for by the EN 60204-1/1992, point 20.1 and following, have had a positive outcome.