

WEDA L80

USER MANUAL

USE - BASIC MAINTENANCE

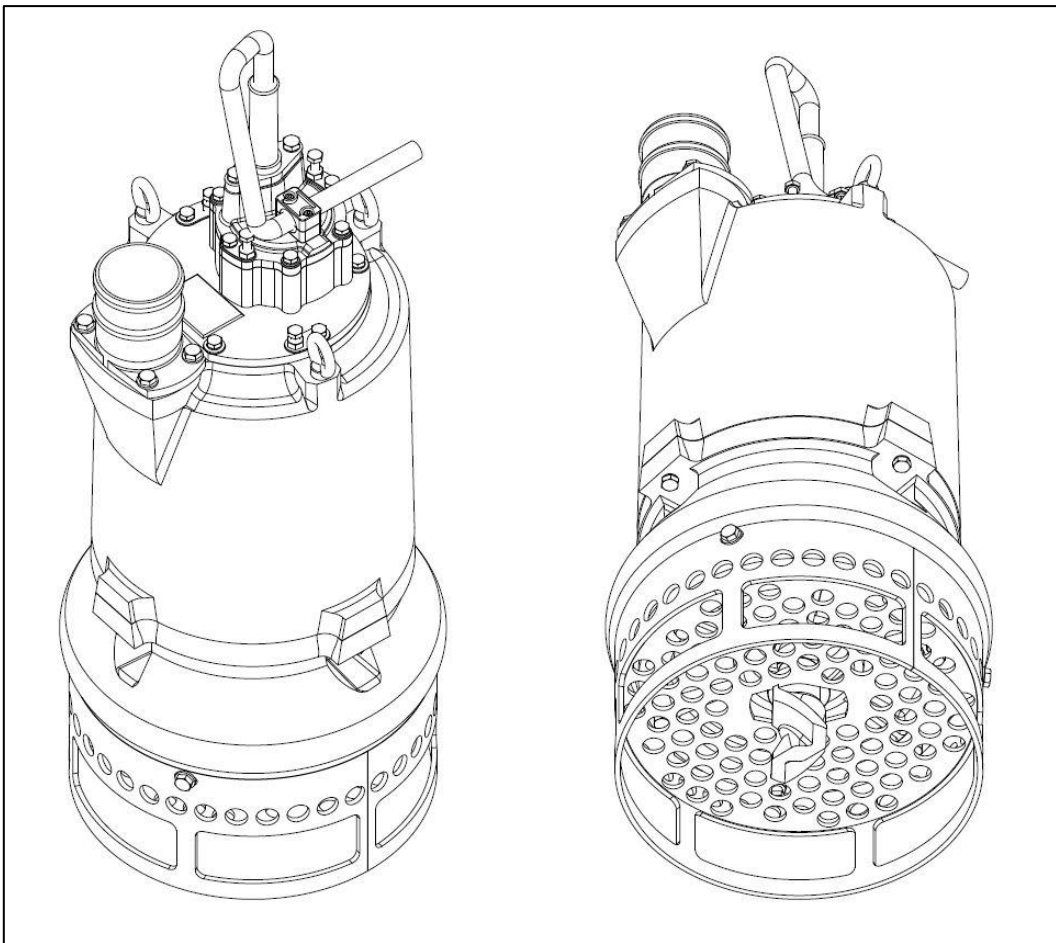

Atlas Copco

Printed matter Nr.
2960 3470 00

CONTENTS

1. Introduction	6
1.1. Identification data	6
1.2. General informations	7
1.2.1 <i>Who is the manual intended for</i>	7
1.2.2 <i>General symbols used</i>	8
1.2.3 <i>Keeping the manual</i>	8
1.2.4 <i>General safety rules and warnings</i>	9
1.3. Technical specifications and reference standards	10
1.4. Manufacturer's warranty	11
1.4.1 <i>Warranty conditions</i>	11
1.4.2 <i>Warranty exclusions</i>	12
1.4.3 <i>Warranty duration</i>	12
1.5. Service Department	13
1.6. How to read the manual	13
1.6.1 <i>Numbering of figures and labels</i>	13
1.7. Service manual	13
2. Description of the equipment	14
2.1. General characteristics	14
2.1.1 <i>Pump plate position</i>	15
2.1.2 <i>Dimensions and weight</i>	15
2.1.3 <i>Technical specifications</i>	15
2.1.4 <i>Electrical devices</i>	16
2.2. Intended use of the machine	16
2.3. Safety of the operators	16
2.3.1 <i>Operating areas and safety</i>	17
3. Transport, installation and dismantling	18
3.1. Transport	18
3.2. Installation	19

3.2.1	<i>Delivery pipe connecting</i>	19
3.2.2	<i>Connecting the power cable to the control box</i>	20
3.2.3	<i>Connecting the power cable to the pump</i>	20
3.3	<i>Dismantling</i>	21
4	Operating instructions	22
4.1	Before starting	22
4.1.1	<i>Before the first start</i>	23
4.2	Starting	26
4.3	Working	26
4.4	Stopping	26
4.5	Emergency situation	26
5	Maintenance	28
5.1	General information	28
5.1.1	<i>Tools for ordinary maintenance</i>	28
5.1.2	<i>Bolts tightening torque</i>	31
5.1.3	<i>Lubricants specifications</i>	32
5.1.4	<i>Exploded view and pump's groups</i>	33
5.2	Maintenance schedule	34
5.2.1	<i>Before every shift</i>	35
5.2.2	<i>After every shift</i>	35
5.2.3	<i>During every shift</i>	35
5.2.4	<i>Every 8 operating hours</i>	36
5.2.5	<i>Every 50 operating hours</i>	36
5.2.6	<i>Every 150 operating hours</i>	36
5.2.7	<i>Pump with optional devices</i>	36
5.3	Maintenance operating instructions	37
5.3.1	<i>Lubricating oil checking</i>	37
5.3.2	<i>Lubricating oil changing/refilling</i>	38
5.3.3	<i>Impeller clearance checking</i>	39
5.3.4	<i>Impeller clearance adjusting</i>	40
5.4	Maintenance replacing instructions	43

5.4.1	<i>Power cable</i>	44
5.4.2	<i>Strainer</i>	44
5.4.3	<i>Lower wear plate</i>	46
5.4.4	<i>Agitator kit</i>	48
5.4.5	<i>Impeller</i>	49
5.4.6	<i>Motor bearing</i>	50
5.4.7	<i>Lower seals</i>	50
5.4.8	<i>Mechanical seals</i>	50
5.4.9	<i>Upper bearings</i>	50
5.4.10	<i>O-ring replacing</i>	50
6	Optional devices	51
6.1	Jet-ring system	51
6.1.1	<i>Spare parts</i>	51
6.2	Compensation system	52
6.2.1	<i>Spare parts</i>	52
6.2.2	<i>Additional maintenance for compensated pump</i>	53
6.3	Temperature sensor	55
6.3.1	<i>Spare parts</i>	55
6.4	Water sensor	56
6.5	Cooling jacket	56
6.6	Cutter knife	56
6.6.1	<i>Spare parts</i>	56
6.7	Aggressive environment kit	57
6.7.1	<i>Spare parts</i>	57
6.8	Waterflush kit	58
6.9	Remote greasing kit	58
6.10	Optional on this pump	58
7	Attachments	59
7.1	Data sheet and performance curves (see next pages)	59

1. Introduction

1.1. Identification data

Read in the following the name and address of the machine manufacturer:

Atlas Copco
Polígono Pitarco II, Parcela 20
50450 Muel, Zaragoza
Spain
Made in Italy

Each machine is equipped with an identification plate that ensures it is produced according to all the European directives in force and the necessary safety requirements. This conformity is certified and is present on the respective identification plate bearing the "EC" marking.

The model, serial number, year of construction are enclosed on the plate placed on the main body of the machine. This data must be mentioned whenever a request for information regarding the machinery is forwarded or for ordering replacement parts.

We recommend to provide, when possible, the following data:

- working hours of the equipment;
- purchase date;
- detailed information on any problems found.

Genuine parts should be used for the replacement of parts of the machine.

The manufacturer declines any responsibility regarding any worsening of performance or damage to the machine or equipment, due to the use of non-genuine spare parts.

1.2 General informations

This manual should be carefully consulted and understood because it contains important information for the safety of operators during the machine use.

In case of doubt or uncertainty on the information provided in this manual please contact the manufacturer for clarification.

However, the machine is intended suitable for uses which is expressly designed for, produced and placed on the market. Any different use must be considered inappropriate and therefore unsafety.

Any contractual or non-contractual liability of the manufacturer shall be excluded for failures and damages caused by errors in the handling and use of the equipment not complying with the instructions given by the manufacturer.

The manual translations from the original language (italian), may be inaccurate or express unintentionally different concepts, therefore refer to the version in the original language or contact the manufacturer for any clarification.

1.2.1 *Who is the manual intended for*

This manual must be read by any operator in charge of installing and using the machine for the intended purposes it was designed, produced and placed on the market.

The operator wording refers to a person without a specific skill, but able to perform safely the following activities:



- handling of loads (also suspended) with lifting devices such as fork lift or hoist;
- mechanical operation such as simple assembling and adjusting;
- cables wiring for disconnected electrical devices;
- machines using with commands and controls on electric panel and suitably described by labels;
- machines using when they are in safety condition with all the provided safety devices in perfect condition, properly installed and completely operative.

The operator must also have basic general culture and technical basic culture to sufficiently read and understand the contents of the manual, including the correct interpretation of images, drawings and pictograms.

It is the responsibility of the user of the machine to ensure the listed operator requirements and to be trained about the health and safety standards in force in the country where the machine is working.

1.2.2 General symbols used

The following symbols (**Tab. 1**) are used within the manual to highlight those operations and instructions particularly relevant.

SYMBOL	MEANINGS
	These safety instructions are indicated with a general pictogram indicating danger.
	Safety instructions related to possible dangers when not observing the electrical safety instructions are indicated with this pictogram. Violating these safety instructions may result in death through electrocution.
	This pictogram indicates safety instructions that can lead to damage to the pump when not observed.

Tab. 1





1.2.3 Keeping the manual

The user manual represents an essential and integral part of the equipment and must be delivered to the user.

It must be carefully kept in a clean place, protected from any predictable agent/event able to damage it.

1.2.4 General safety rules and warnings

The manufacturer ensures the utmost commitment to make the equipment as safe as possible, providing it with all the guards and safety devices deemed necessary. Finally, the equipment has been accompanied with all the sufficient information to be used safely and correctly.

	Do not allow non-qualified operator to use the machine.
	Before beginning any operation on the machine, the operator must be aware of the location and meaning of all commands and controls.
	Before beginning any operation on the machine, make sure that all the guards and protections are correctly installed, in perfect condition and completely efficient.
	During the working operations, the operator must be provided of the suitable personal protective equipment.

It's responsibility of the user to determine the working condition during the machine use and consequently decide the required personal protective equipment. Any suggestion given in this manual about a personal protective equipment use does not replace the mentioned obligation on the part of the user.

	Use the equipment within the limits indicated in the technical specifications.
---	---

1.3 Technical specifications and reference standards

The equipment has been designed and built based on the customer's specific requests, defined within the contract. Nevertheless any machine is designed, produced and placed on the market by the manufacturer in compliance with all the required standard in force UE during the period of manufacture.

See below the reference standards (if applicable) for the machine:

- Machinery Directive 2006/42/EC;
- Directive 2014/35/EU concerning the safety for the electrical equipment used under "low voltage";
- Directive 2014/30/EU on electromagnetic compatibility;
- Directive 2014/68/EU on equipment with components under pressure;
- Standard ISO 898-1: 2013 for mechanical fastening;
- Standard ISO 12151-1: 2017 for hydraulic fittings.

1.4 Manufacturer's warranty

The manufacturer guarantees the original user that the machine will be reasonably free from factory and material defects.

In case of unpredictable defects, the user can claim the warranty.

Any warranty request must be recognized by the manufacturer as being subject to the warranty conditions after presentation of adequate proof of claim, and eventually accepted in one of the following ways, at the discretion of the manufacturer:

- replacement of defective part with a new one, made available in the offices of the purchaser at the lowest transport rate;
- repair of defective part, after this has been returned to the manufacturer with transport expenses prepaid.

In the first case, as soon as the new spare is ready, the user will make the defective part available to the manufacturer workshop for inspection.

The manufacturer declines all responsibility for the expenses due to “down time”, business costs and losses deriving from faults and failure, even if under warranty conditions.

Any claim for warrantable failures shall be sent in writing to the manufacturer prior to the expiry of the warranty period.

This warranty is the sole warranty provided by the manufacturer.

There are no other warranties, explicit or implied, provided by the manufacturer.

1.4.1 Warranty conditions

The warranty does not apply to those parts that result defective because of incorrect use and handling or bad observance of the use and maintenance instructions supplied by the manufacturer.

The warranty completely expires as soon as non genuine spare parts are installed on the equipment without the manufacturer permission.

The warranty on the electric motor and other warrantable components damaged due to electric faults is applied only if the power supplying devices installed (power generator, power cable, electric/control panel) are supplied by the manufacturer and are specifically suitable for the present machine.

If the user tries, either to repair by his own any fault that is under guarantee or to use spare parts not supplied directly by the manufacturer without his previous written consent, the latter will not be responsible for the results of the repair and will not be held to reimburse the expenses sustained by the user.

1.4.2 Warranty exclusions

The warranty is not applied for the following listed parts subject to usual wearing:

- gaskets and sealing components;
- shaft sleeves;
- impeller kit;
- agitator kit;
- upper/lower wear plates;
- casing;
- strainer
- discharge adapter;
- any other component directly in contact with the dredge material flow.

The warranty is not applicable to the following electric components:

- power cables (when supplied);
- terminal board.

The warranty is not applicable to any consequential damage due to the failure under warranty claim.

1.4.3 Warranty duration

The warranty lasts for 1 year from the delivery date specified in the contract.

If the contract condition foresees the machine start-up performed by a manufacturer technician, the duration of guarantee is 12 months from the start-up date and in any case not over 16 months from the delivery date specified in the contract.

1.5 Service Department

For any inconvenient or technical request, please contact the manufacturer Service Department.

To locate a specific component of the equipment please refer to the diagrams and the exploded views contained in this manual.

Always refer to the sections of the manual dedicated to the use and maintenance.

Contact the Service Department if it is not possible to solve the problem on site by your own.

1.6 How to read the manual

For a correct reading and consultation, this documentation has been conveniently divided into chapters. They are listed in the general index.

Some picture may not represent exactly the equipment with differences that anyway don't affect the accuracy of the given information.

1.6.1 Numbering of figures and labels

Each figure and table included in the manual is numbered in a progressive manner, chapter by chapter.

Any label inside the figures could be a number, only when referred directly to a position of the pump parts list, or letter.

1.7 Service manual

This manual provides instructions for the use and the basic maintenance of the machine, concerning activities normally achievable in a generic environment.

Any other maintenance activities require to be performed in a workshop. In this case, refer to the Service Department or to the Service Manual (available on request) for assistance and instructions.

2 Description of the equipment

2.1 General characteristics

The electric motor driven pump (**Fig. 1**) is made up of a cylindrical motor housing **[3]** inside of which is located an electrical motor **[B]**. The upper support **[40]** is completely water-tight, and contains the terminal box for connection to the electric motor; the waterproofing is guaranteed by the cover and by a series of seals **[D]**. Inside the oil chamber/casing **[4]** is located the group of mechanical seals **[F]** that prevents the water from passing to the motor.

On the main shaft **[2]**, inside the oil chamber/casing **[4]** there is a keyed impeller **[1]**, made in high chrome content anti-wear materials. A lower wear plate **[7]**, made with the same material, partially closes the impeller inlet. Inside the strainer protection **[50]** houses an agitator **[10]** that rotates and stirs the mixture of solids in the water to be pumped.

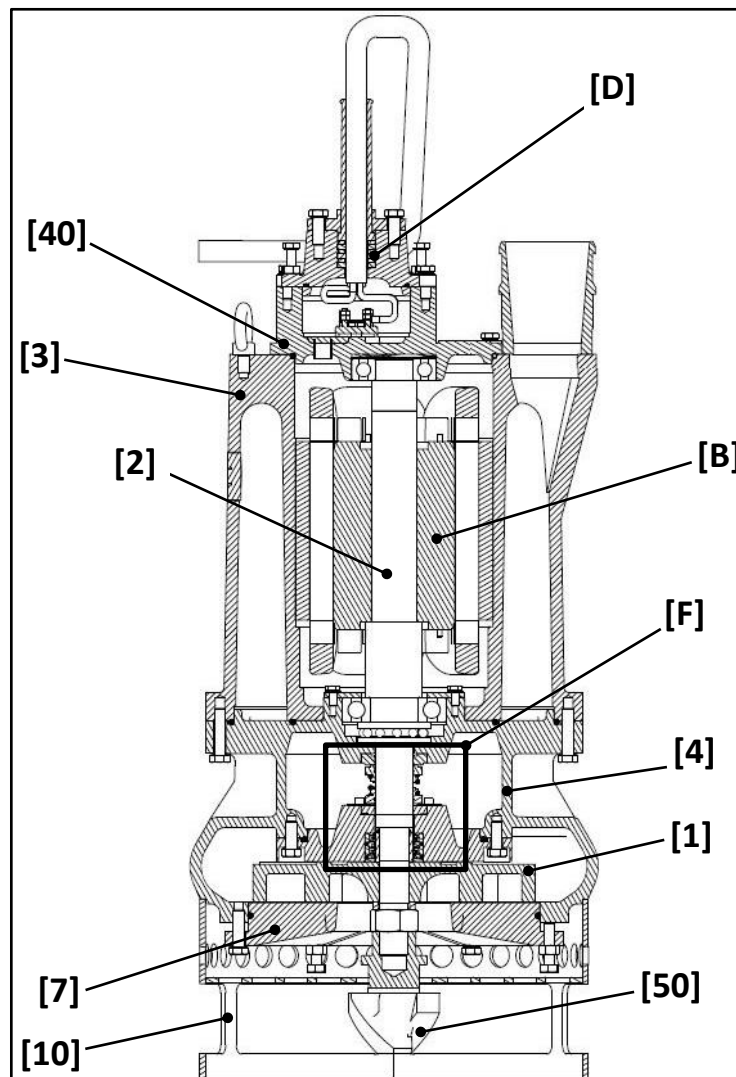

Fig. 1

2.1.1 Pump plate position

See Fig. 2 for the position of the machine identification plate.

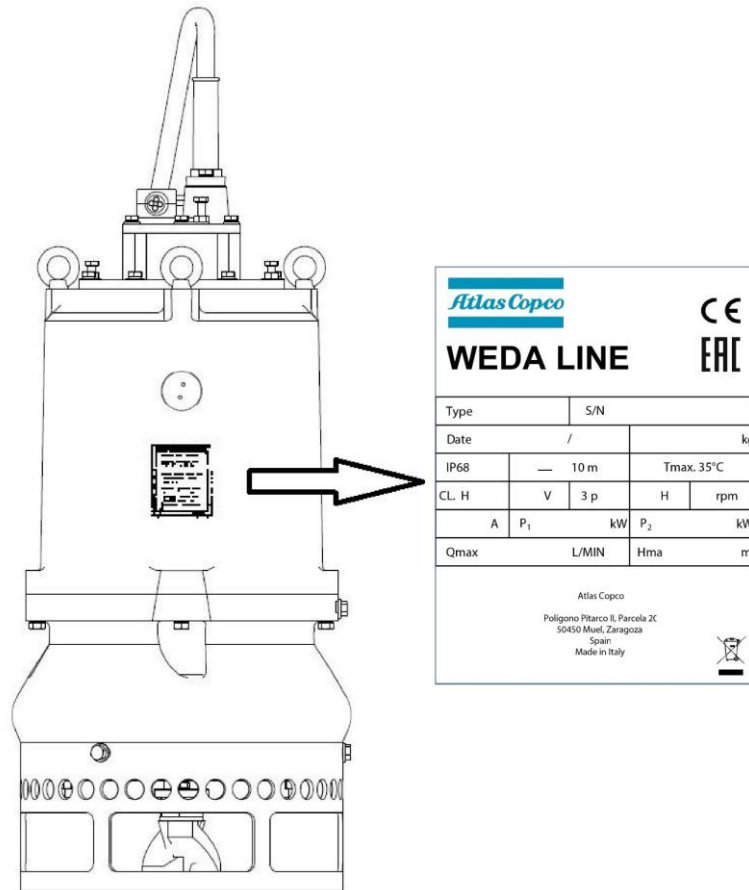

Fig. 2

	The electric data AMP (current absorbment) and HP/KW (power) indicate the maximum values. Never exceed these values during continuous operation.
	The electric data VOLT (voltage) indicates a nominal value. Never exceed a 10% variation of these value during continuous operation.

2.1.2 Dimensions and weight

Refer to the data-sheet of the pump (see chapter **Attachments**) for overall dimensions and weight.

2.1.3 Technical specifications

Refer to the data-sheet of the pump (see chapter **Attachments**) for any technical specifications (performance, materials, plate data).

2.1.4 Electrical devices

The pump cannot operate without previous connecting to a power source (such as power generator) and a control panel.

Before using the pump, take care that all these electric devices are suitable to the electric specification of the machine (see the machine plate and data-sheet) and meet the related international standards, especially about the safety of the operator and the safeguard of the equipment.

The pump is not provided of an Emergency Stop button on board. Any electrical system used for the power supply of the pump must be provided with the Emergency Stop button.





The Emergency Stop button must stop instantly any electrical connection to the pump after pushing and must keep the pump disconnected without resetting. After resetting the Emergency Stop button, the pump cannot start automatically.

2.2 Intended use of the machine

The machine is designed produced and placed on the market for dredging operations, that is pumping underwater a mixture of water and solid materials (sand, mud, rocks of suitable dimensions) with density variable depending on the working condition.

2.3 Safety of the operators

The machine has been designed and produced with all the possible precautions to carry out dredging operations under the utmost safety conditions, considering the current state-of-the-art for this kind of equipment.

	Before beginning any operation on the machine, the operator must be aware of the location and meaning of all commands and controls.
	Before beginning any operation on the machine, make sure that all the guards and protections are correctly installed, in perfect condition and completely efficient.
	During the working operations, the operator must be provided of the suitable personal protective equipment.
	During dredging operations, the operator must stay near the control panel and no one must remains close to the dredging area.

However, the best approach to avoid risks and prevent the damages is to use the equipment exclusively for the intended use with expertise and caution.

Remember the followings:

- read with care and completely the present manual and the annexes, if present;
- don't hesitate to contact the Service Department of the manufacturer in case of doubt or need;
- before every use, check carefully the integrity of the equipment and all its components, with care for safety and lifting equipment.

2.3.1 Operating areas and safety

The operating area for the operator of the machine is close to the control panel. During working operation, the machine is placed underwater and the operator must stay in the defined operating area. No one must remain close to the dredging area. The control panel must be placed in a dry and clean position. Take care that the control panel is closed and every access inside it is denied without shutting down the electric power.

During maintenance operation, the machine could be placed out of water. In this occasion, operate on the machine only with the electric power shut down.

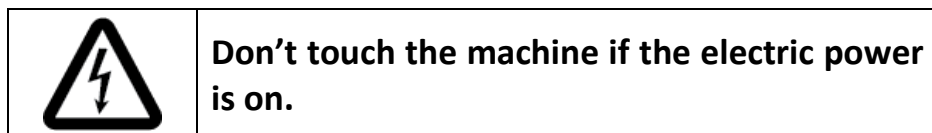

During maintenance operation, starting the machine out of water could be required. In this occasion, any person must stay at a safety distance from the machine (not less than 2 meters) in a dry and clean place. Before starting in this condition, check that the machine is clean, specially its rotating components.

3 Transport, installation and dismantling

3.1 Transport

The pump is generally supplied encased inside a crate to avoid damage during transport. The crate is arranged for moving with a fork-lift truck (**Fig. 3**), whose capacity must be able to sustain the weight of the machine (see data sheet enclosed in the **Attachment** chapter). The pump is provided with lifting point (**A**) as shown in **Fig.3**. Use this lifting point to move and position the pump.

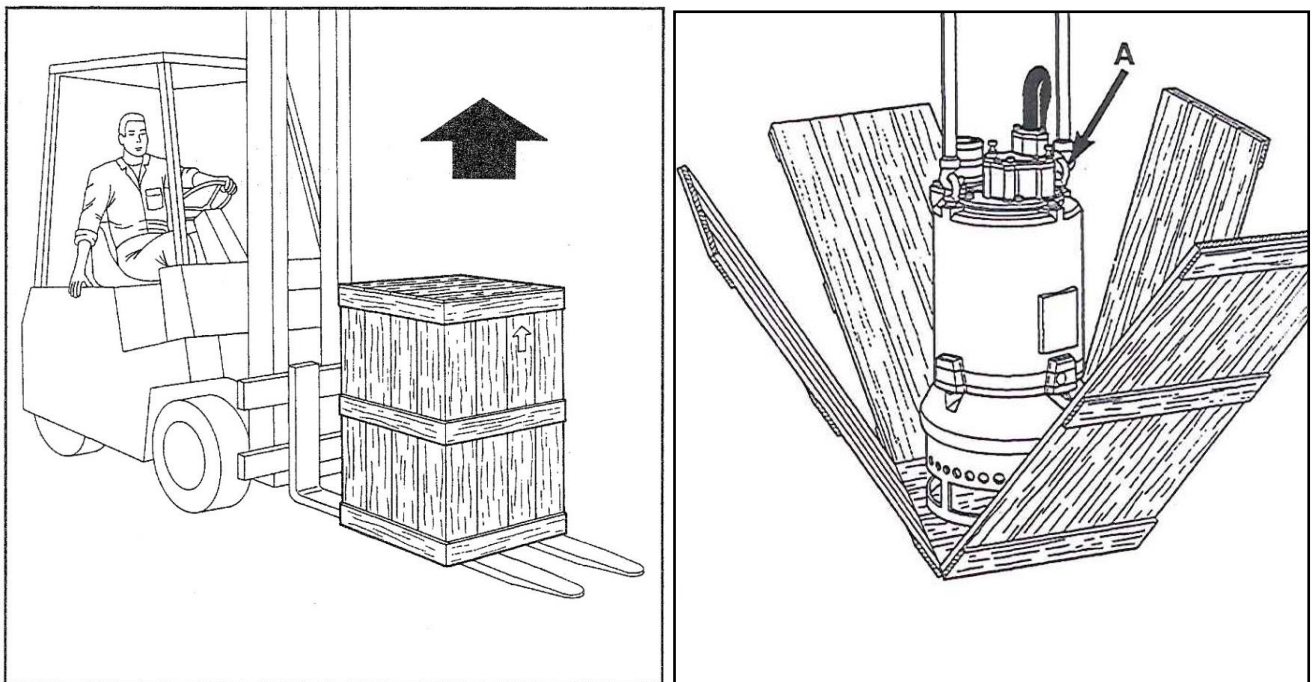





Fig. 3

	After checking the weight of the machine, use adequate lifting equipment to move and position it.
	Check the condition of the lifting point before every lifting and moving operation.

3.2 Installation

The installation of the pump requires to be performed by a operator skilled on suspended loads handling, mechanical assembling and electrical wiring.

	<p>Some operations should be performed in environment with deep water risks, wet surfaces risks, suspended loads risks and handling loads risks with danger of drowning, slipping, crushing and trapping. Wear appropriate safety personal protective equipment.</p>
---	--

3.2.1 Delivery pipe connecting

Connect the delivery pipe to the exit flange of the pump. Refer to the data-sheet (see chapter **Attachments**) for the correct size of the connections.

The delivery pipes must never form siphons (**Fig. 4**) to avoid problems due to the formation of air pockets or deposits of solid material.

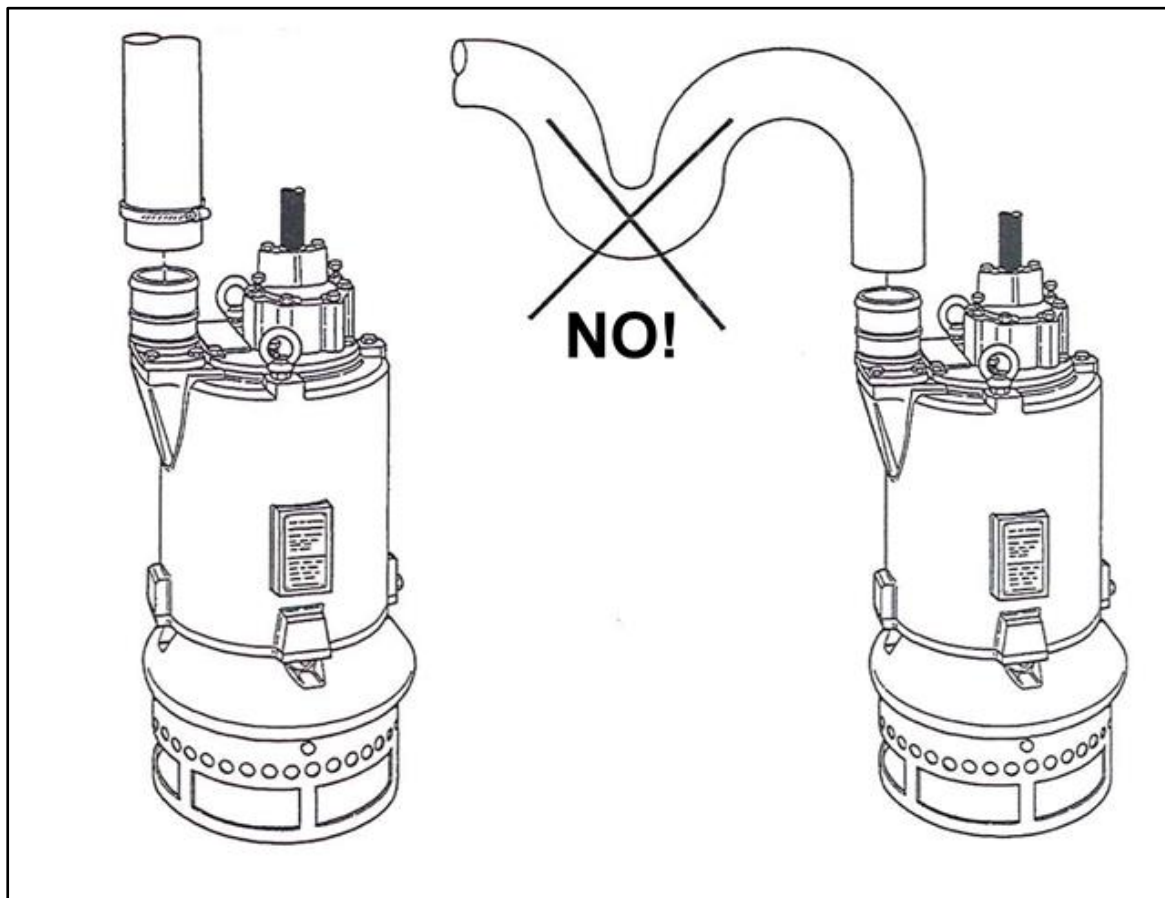



Fig. 4



3.2.2 *Connecting the power cable to the control box*

Connect the pump to the electrical source with the power cable (if not supplied) already connected on board.

Before connecting the pump to the electrical supply source, make sure that all the specifications of the power generator and control box are suitable to the electric data on the rating plate (voltage, power, absorption, frequency) of the machine.

	Before connecting the pump to the electric source, make absolutely sure that this is shut down and without the voltage.
---	--

Connect the cable to the control box, taking care to respect the power supply phases. The correct rotation of the pump depends on the three phases connecting order. If the pump doesn't rotate correctly, switch two phases of the power cable on the control panel terminal board.

	Always connect ground wire (normally the yellow/green one) to the general grounding system of the plant.
	The user must guarantee the electrical conductivity between the pump and the main grounding system of the plant.

3.2.3 *Connecting the power cable to the pump*

If the power cable is not available, connect a suitable power cable to the terminal board of the the pump. Refer to the data of the rating plate (voltage, power, absorption, frequency) of the pump for a correct power cable choosing. Refer to the Service Manual for the power cable on-board connecting instructions.

3.3 Dismantling

Before any dismantling operation, ensure to place the pump in a safe position and disconnect the electrical supply and the delivery pipes.

The machine that is considered completely useless must be removed from the work site and collected by the manufacturer or any other firm specialized in demolition. Remember that dismantling the machine will produce different materials (metals, plastics, oil, etc.) whose disposal will be done in compliance with the legislative regulations in force in the state where the machine is found.



During dismantling, you could have some oil leaks. Be sure to collect the leaked oil and to maintain clean the environment.

4 Operating instructions

The pump has been created to pump suspended matter, even with solid parts, as long as water is always present. It can be used for civil and industrial purposes, as long as conditions described in this manual are observed.

In the following, it is assumed that the pump can start/stop after enabling/disabling the electric power supply with a generic on/off device on the control panel. This represents only a simplified condition and doesn't represent the complete solution for the electric devices required to a safe use of the machine.

Ensure that the piping is connected to the pump with diameter, length and total system load loss suitable for the nominal duty point of the pump.

4.1 Before starting

Before any starting, always ensure the following conditions:

- no one can stay in the dredging area of the pump;
- the operator place must be clean and dry;
- the operator can easily inspect the dredging area of the pump;
- any electric device must be closed and in safety conditions;

	<p>Never operate the immersed pump without connecting the discharge pipes, because in absence of the foreseen load loss, the electric motor could overshoot the maximum current absorption and in the absence of the suitable safety devices be completely damaged.</p>
---	--

Before any starting, it's also good practice to check the following general conditions of the machine:

- coating of the external surfaces;
- integrity of the power cable and all the external waterproof/sealing component installed in the inlet area of the power cable;
- general tightening of bolts and threaded components.

4.1.1 Before the first start

The following specific operation must be performed before the first start:

- check the presence of the lubricating oil in the oil chamber by unscrewing just a little the “OIL” plug [A] to verify if some drop of oil comes out (see Fig. 5):

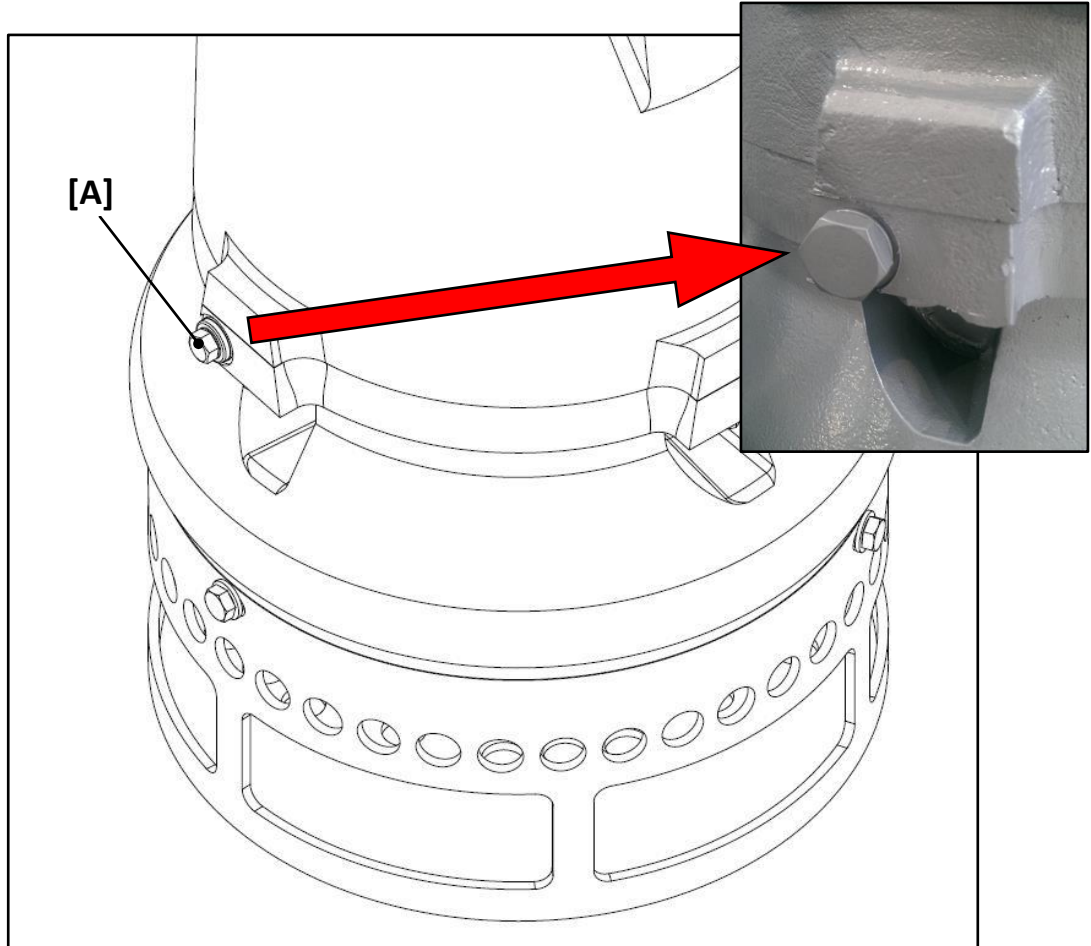

Fig. 5

- if oil is not found, fill completely the oil chamber (see *Lubricating oil changing/refilling* in the Maintenance section);



Always use the suggested lubricating oil or other type with equivalent properties (see *Lubricants specifications* in the Maintenance section).

- check the tightness of the agitator [10] and all the other threaded components of the agitator kit (see Fig. 6): in detail, be careful to the full tightening of the connector element [11] and the nut [12] in order to ensure a complete and strong contact between the spacer [13] and the impeller [1] (see Fig. 6);

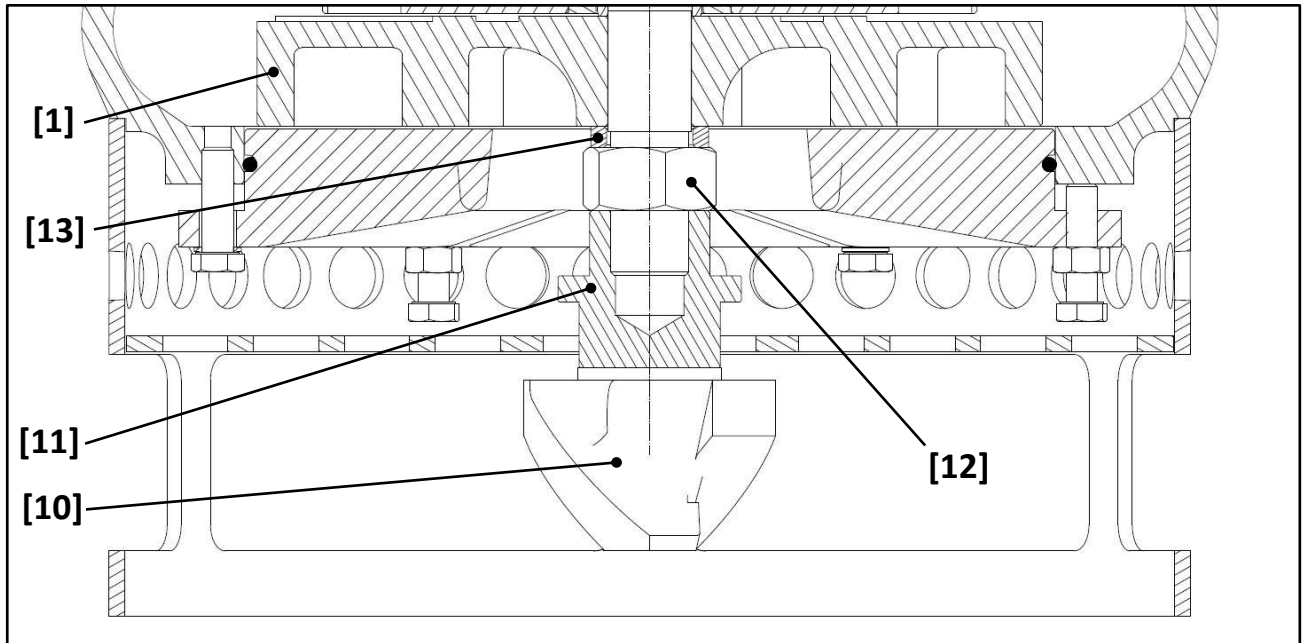
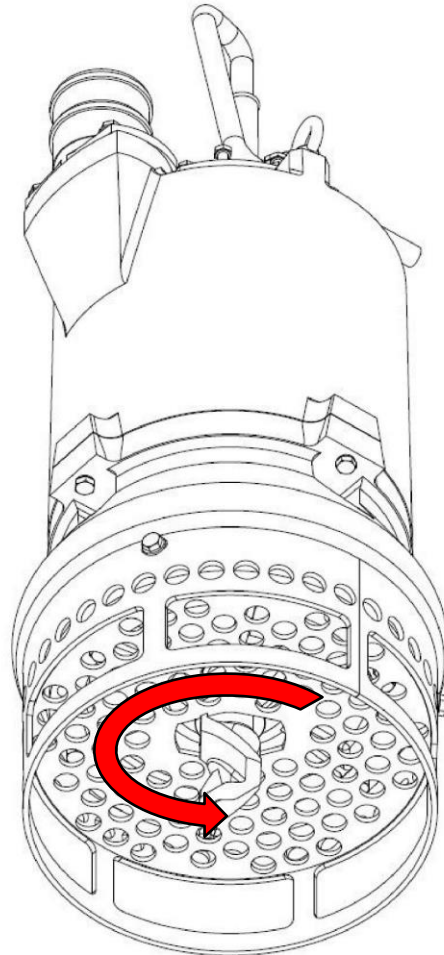

Fig. 6

- placing the machine in a stable position out of the water, start it for a short time (not more than 10 seconds) and check the correct rotation comparing it with the red arrow printed on the plate (see **Fig. 7**) and eventually switch two phases of the power cable on the control panel terminal board;



		CE	
WEDA LINE		EAC	
Type	S/N		
Date	/	kg	
IP68	—	10 m	Tmax. 35°C
CL. H	V	3 p	H rpm
A	P ₁	kW	P ₂ kW
Qmax	L/MIN		Hma m
Atlas Copco Polígono Pitarco II, Parcela 20 50450 Muel, Zaragoza Spain Made in Italy			

Fig. 7

	Before switching the phases into the control box, make absolutely sure that this is shut down and without the voltage.
--	---

- take care of any noise or vibration that could mean some unforeseen anomalous condition of the machine.

	During the first starting, inform immediately the manufacturer Service Department about any anomaly.
--	---

4.2 Starting

Starting the pump, perform the following instructions:

- place the pump completely submersed in the clean water without touching solid material;
- start the pump and wait that a complete flow of clean water exits from the discharge line;
- if any priming problems should come up, stop the pump and wait for about 30 seconds, leaving it immersed, until all the air has been eliminated then restart and check the clean water flow;
- slowly lower the pump until it's in contact with the material and the mixture water/solids flow exits from the discharge line.

4.3 Working

During working, the operator must perform the following instructions:

- keep on to maintain the contact with the material, moving down the pump with care;
- avoid to push hard the pump into the material;
- don't dredge in the same place for a long period, avoiding to create an hole in the material where the pump might get stuck;
- check the percentage of solid in order not to go over the maximum absorption limit (see pump plate);
- check the current absorption value in order to understand the working load of the pump.

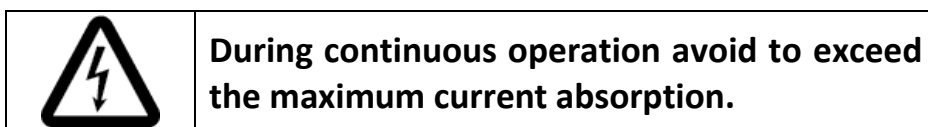

4.4 Stopping

Before stopping the pump, it is always a good practice to lift the pump from the material and pump only clean water in order to wash the pipes and prevent sedimentation and piping clogging.

4.5 Emergency situation

The correct use of the machine excludes the possibility of emergencies happening during operation or during cleaning and maintenance, unless the latter have not been done in compliance with this instructions manual.

In case of imminent danger, press the Emergency Stop button, and immediately afterwards operate to cutout the power supply.





An accurate search to detect the fault or anomaly that caused the danger must be carried out soon afterwards.

Reset the Emergency Stop button only after solving the fault and any maintenance operator has left the area close to the pump (see the ***Operating areas and safety*** section).

If necessary, ask assistance to manufacturer Service Department.

5 Maintenance

5.1 General information

	Any maintenance operation must be executed with the power supply of the machine shut off and any movable device stopped and blocked.
	Any maintenance operation must be executed with the pump well cleaned and placed in a stable position and in a suitable area.
	Any maintenance operation must be executed by qualified operators with skills depending on the type of intervention and device to maintain.
	During maintenance, wear appropriate safety personal protective equipment.

Many maintenance operations should be performed with the pump placed in a particular position. The pump can be placed vertically (also overturned) or orizzontally, depending on the convenience. In any case, be careful to move the pump only by its lifting point and to provide, when required, an holding frame capable to sustain the pump in any position with safety for the operators and the equipment.

Pay particular attention to move components exceeding the maximum weight for manual handling, using the adequate tools and complying the health and safety regulations in force.

5.1.1 Tools for ordinary maintenance

The ordinary maintenance of the pump requires the following tools:

- 1 set of dynamometric wrenches (up to 1000 Nm) and sockets;



Fig. 8

- 1 set of wrenches (from 6 to 36 size + 46 size);



Fig. 9

- 1 set of Allen key (from 1.5 to 10)

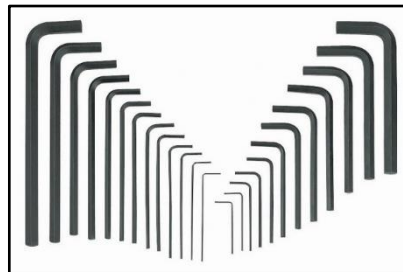

Fig. 10

- 1 steel, 1 rubber hammer and a wood piece for soft strokes



Fig. 11

- 1 set of Seeger pliers

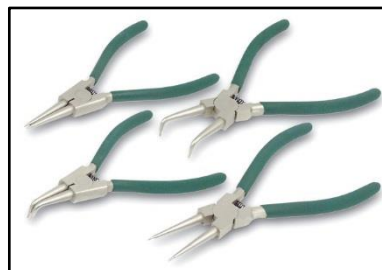

Fig. 12

- 2 parrot pliers



Fig. 13

- 1 set of screwdriver (flat and cross head)



Fig. 14

- 1 multimeter + 1 RPM counter



Fig. 15

- lifting equipment



Fig. 16

	<p>See carefully the machine weight on the data plate for correct choosing of any lifting equipment.</p>
--	--

5.1.2 Bolts tightening torque

See below the suggested tightening torque T_s for most common bolts size:

d mm	T_s (N · m)					d mm
	4.6	5.6	6.6	8.8	10.9	
12	39	48	58	90	113	12
14	62	77	93	144	180	14
16	96	121	145	225	281	16
18	133	166	199	309	387	18
20	188	235	282	439	549	20
22	256	320	384	597	747	22
24	325	407	488	759	949	24
27	476	595	714	1 110	1 388	27
30	646	808	969	1 508	1 885	30

Tab. 2

5.1.3 Lubricants specifications

See below the technical characteristics of the lubricating oil of the pump:

PROPERTY	UNIT	REF. STANDARDS	TYPICAL VALUE
OIL TYPE	-	-	ISO VG 32
DENSITY (15°C)	[g/cm ³]	ASTM D4052	0.865 – 0.885
VISCOSITY (40°C)	[cSt]	ASTM D445	28.8 – 35.2
FLASH POINT	°C	ASTM D92	≥200

Tab. 3

See below the technical characteristics of the lubricating grease of the pump:

PROPERTY	UNIT	REF. STANDARDS	TYPICAL VALUE
GREASE TYPE	-	-	MINERAL
ACTIVE COMPONENT	-	-	PTFE
THICKENER	-	-	litium complex
OPERATING TEMP.	°C	-	-20 / +125
WASHOUT RESISTANCE (1hr – 38°C)	%	ASTM D1264	2.8
DROPPING POINT	°C	ASTM D2265	>267
FLASH POINT	°C	ASTM D92	277
DENSITY (25°C)	[g/cm ³]	ASTM D1480	0.899
VISCOSITY (40 °C)	[cSt]	ASTM D445	142

Tab. 4

The manufacturer suggest the following brand and type of lubricating oil and grease:

- oil: PETRONAS HYDROBAK 32
- grease: TECNOLUBE POLYMER 400/2

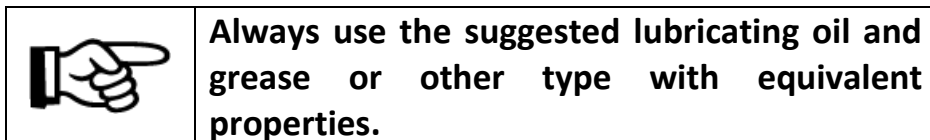

Refer to the manufacturer Service Department in case of difficult to find the suggested lubricating oil and grease.

5.1.4 Exploded view and pump's groups

See in **Fig. 17** the exploded view of the pump, identifying the followings groups:

- **[A]** Electric motor group;
- **[B]** Oil chamber/Casing group;
- **[C]** Impeller kit;
- **[D]** Agitator kit.

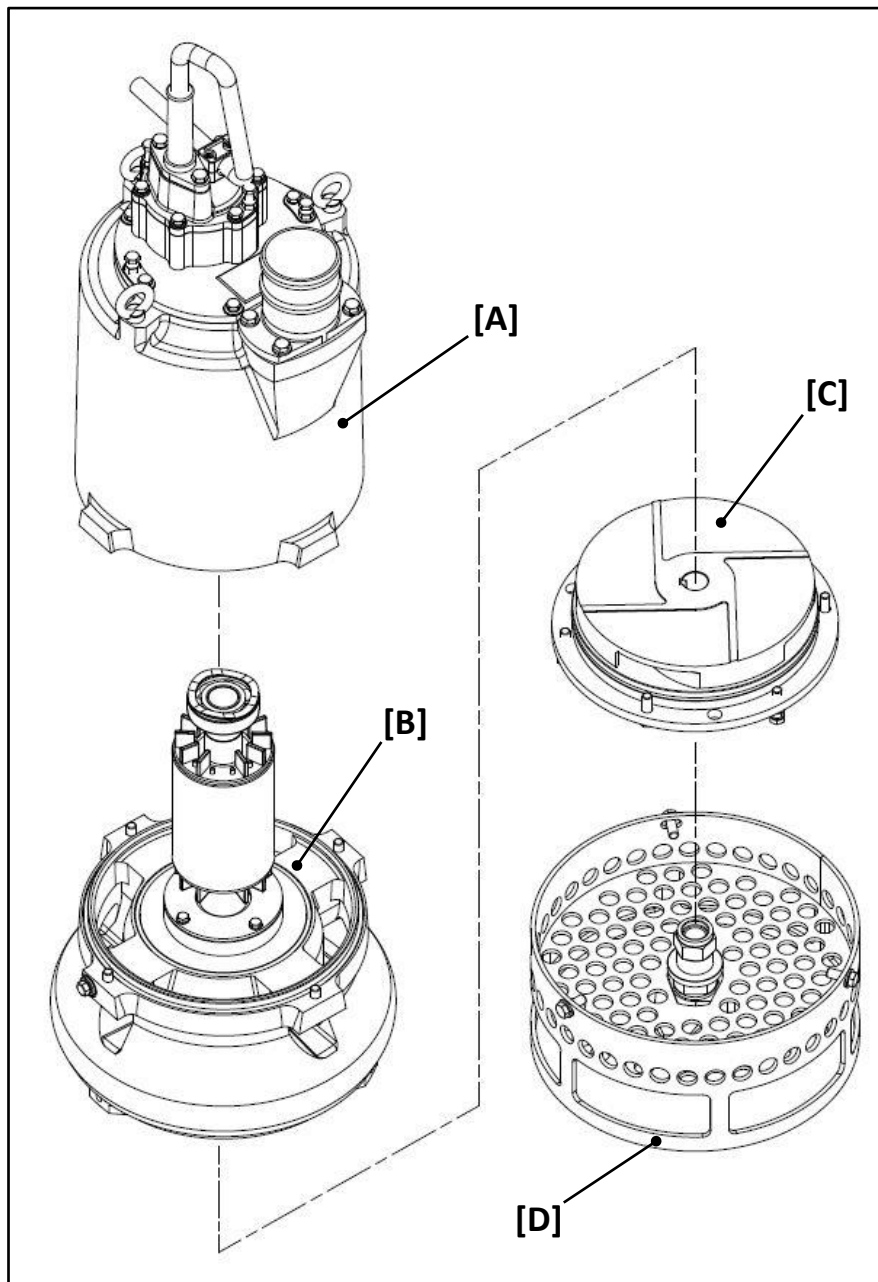

Fig. 17

5.2 Maintenance schedule

The pump has components requiring a scheduled checking and maintenance due to wearing and performance loosing. Some of them are relevant components for the safety of the machine (see **Fig. 18**). Perform carefully any maintenance operation related to these components.

The listed schedule-times in the next pages are only a suggestion referring to a standard use of the equipment. It's responsibility of the user to increase the scheduled maintenance in case of more heavy working condition of the machine.

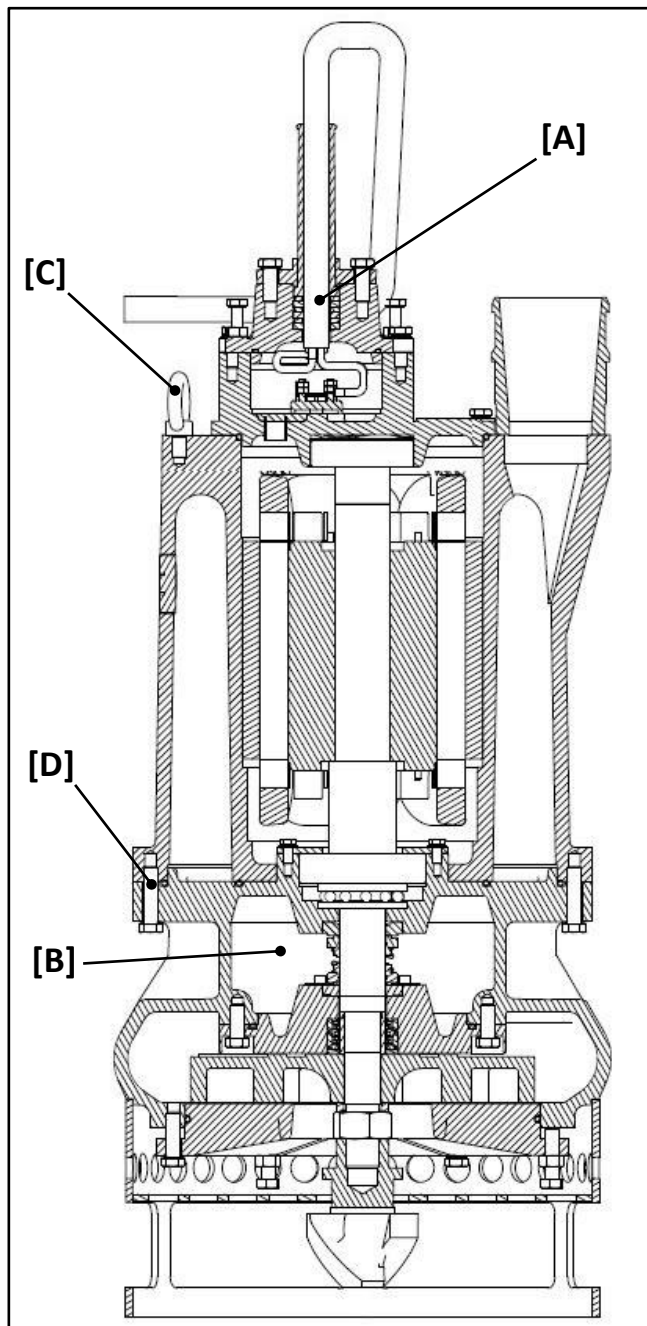

Fig. 18

[A]	Power cable and waterproof seals
[B]	Lubricating oil
[C]	Lifting point
[D]	Bolts tightening

5.2.1 Before every shift

Activity	Eventually...
Check for the good conditions of the power cable and its inlet waterproofing components.	See the section Power cable in the Service Manual or call the Service Department.
Check for any anomalous noise or vibration by starting the pump out of the water for no more than 10 seconds.	Contact the Service Department for more in-depth analysis.
Check for the good functionality of the Emergency Stop button on the control panel.	Replace it before starting any working operation.
Check for the good conditions of the lifting points and lifting equipment used for the pump moving.	Replace them before starting any working operation.

Tab. 5

5.2.2 After every shift

Activity	Eventually...
Check for the cleaning condition of the inlet zone of the pump.	Remove any object or material clogging the strainer and the suction area of the pump.
Wash the external surfaces of the pump with clean water.	-

Tab. 6

5.2.3 During every shift

Activity	Eventually...
Check for the good performance of the pump (typically working amperage and slurry production).	See the sections: <ul style="list-style-type: none"> - Impeller clearance checking - Impeller clearance adjusting - Agitator kit - Impeller in this manual.
Maintain clean and dry the control panel and the operator working area.	-

Tab. 7

5.2.4 Every 8 operating hours

Activity	Eventually...
Check for the good lubricating oil conditions in the oil chamber (see the section Lubricating oil checking).	See the section Lubricating oil changing/refilling .

Tab. 8

5.2.5 Every 50 operating hours

Activity	Eventually...
Check the tightening of the bolts and of any other threaded component of the pump.	Tight correctly (see Bolts tightening torque in this manual)
Check for the good conditions of the agitator.	See the section Agitator kit in this manual

Tab. 9

5.2.6 Every 150 operating hours

Activity	Eventually...
Check the clearance between impeller and lower wear plate (see the section Impeller clearance checking).	See the section Impeller clearance adjusting .

Tab. 10

5.2.7 Pump with optional devices

	Some pump equipped with optionals could require further or different maintenance operations. In this case, refer to the Optional devices section for the complete maintenance descriptions and instructions.
---	---

5.3 Maintenance operating instructions

5.3.1 Lubricating oil checking

The lubricating oil check must be performed every 8 hours. The purposes of this operation are:

- to verify the oil quantity;
- to verify the oil condition.

Check the quantity/condition of the lubricating oil in the oil chamber by slightly unscrewing the "OIL" plug [A] (without removing it) (see **Fig. 19**):

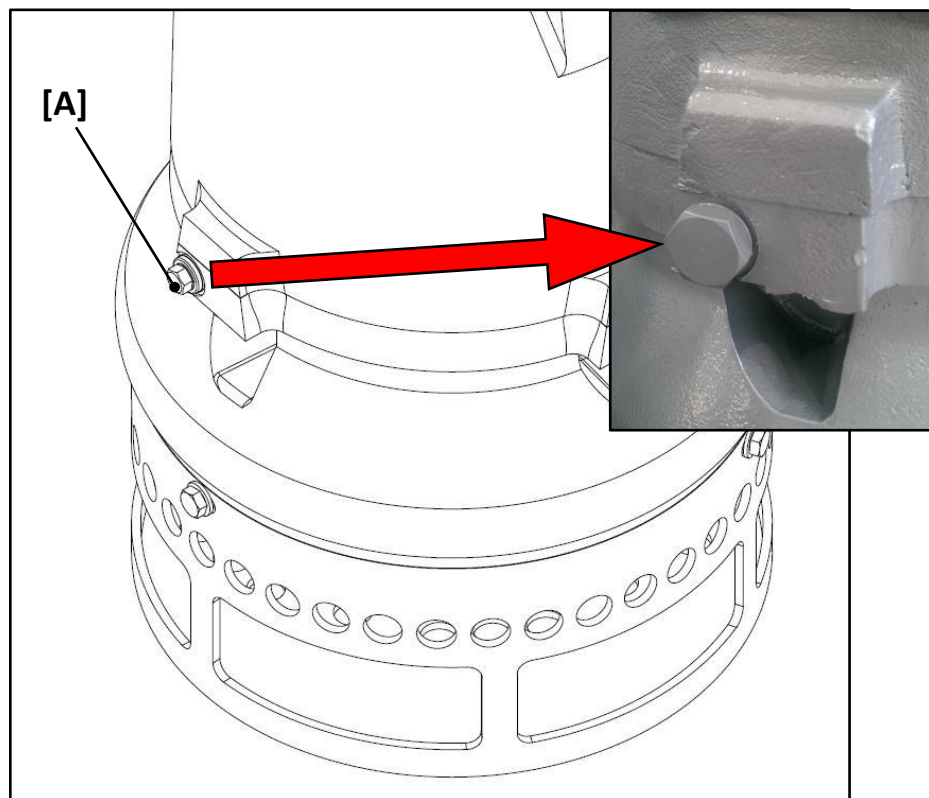

Fig. 19

With the pump in vertical position, some drop of oil must exit from the partially plugged hole if the quantity is correct. Refill eventually (see **Lubricating oil changing/refilling**).

Check a sample of oil to understand its condition and presence of impurity or water. In case of deterioration of the oil provide for its complete replacing (see **Lubricating oil changing/refilling**). In case of presence of impurity or water, provide also for a seals replacing (call the Service Department or see **Lower seals** and **Upper seals** in the Service Manual).

5.3.2 Lubricating oil changing/refilling

Before changing the oil, it's a good practice to completely empty the pump of the remaining oil:

- place orizzontally the pump, with the "OIL" plug [A] pointing down;
- removing the "OIL" plug [A] and its copper washer, let the existing oil exiting completely from the oil chamber (see Fig. 20);

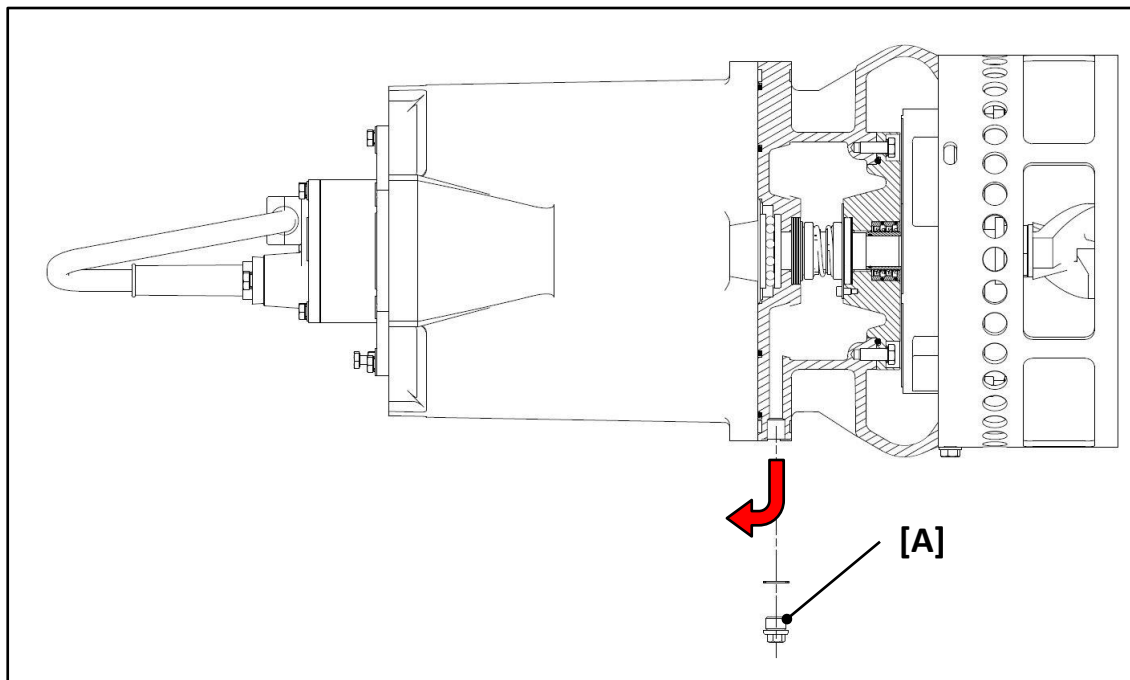

Fig. 20



Avoid to pollute the environment with the exhausted oil dispersion. Collect and dispose it in conformity with the local laws.

- place orizzontally the pump, with the "OIL" plug [A] pointing up;
- top up until completely full the oil chamber through the inlet plug hole [A] with new oil (≈ 5 kg);



Always use the suggested lubricating oil or other type with equivalent properties.

- reassemble and fully tight the inlet plug [A], checking the conditions of its copper washer (replace it if damaged).

5.3.3 Impeller clearance checking

This check must be performed every 150 operating hours in order to prevent a performance loss of the pump.

For the impeller clearance checking, proceed as follows (see **Fig. 21**):

- remove the strainer (see **Strainer** section);
- using a feeler, check that the space between the lower wear plate [7] and the impeller [1] doesn't exceed 1 mm;
- if the measured clearance is more than 1 mm, proceed immediately with the clearance adjusting (see **Impeller clearance adjusting** section).

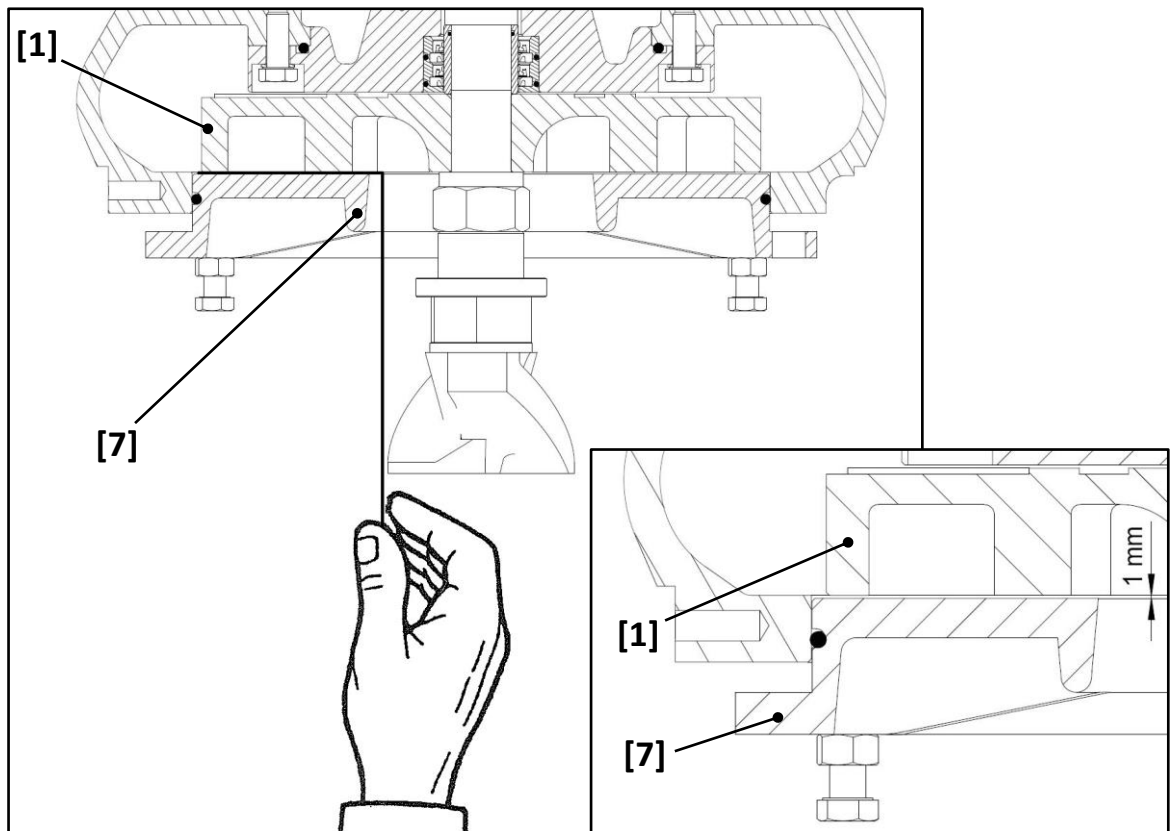

Fig. 21

Reassemble all the components in reverse order to restore the pump at the initial conditions. Before reassembling, check the good conditions of any bolt and eventually replace the damaged ones.

5.3.4 Impeller clearance adjusting

For the impeller clearance adjusting, proceed as follows:

- place the pump vertically and overturned in a stable and safe condition and remove the strainer (see **Strainer** section) (**Fig. 22**);
- loosen completely the n°3 adjusting bolts [206] and make sure that the wear plate gets in contact with the impeller (see **Fig. 23a**);
- screw the same n°3 adjusting bolts [206] until 1 mm of clearance between wear plate and impeller is reached (use 3 feelers positioned at 120° on the inlet hole diameter between the lower wear plate and the impeller) (see **Fig. 23b**);
- fix the wear plate position by completely screwing the n°3 nuts [401] maintaining the adjusting bolts [206] blocked and remove the feelers (see **Fig. 24a**);
- block the wear plate by completely screwing the n°3 bolts [205] (see **Fig. 24a**).

Reassemble all the components in reverse order to restore the pump at the initial conditions. Before reassembling, check the good conditions of any bolt and eventually replace the damaged ones.

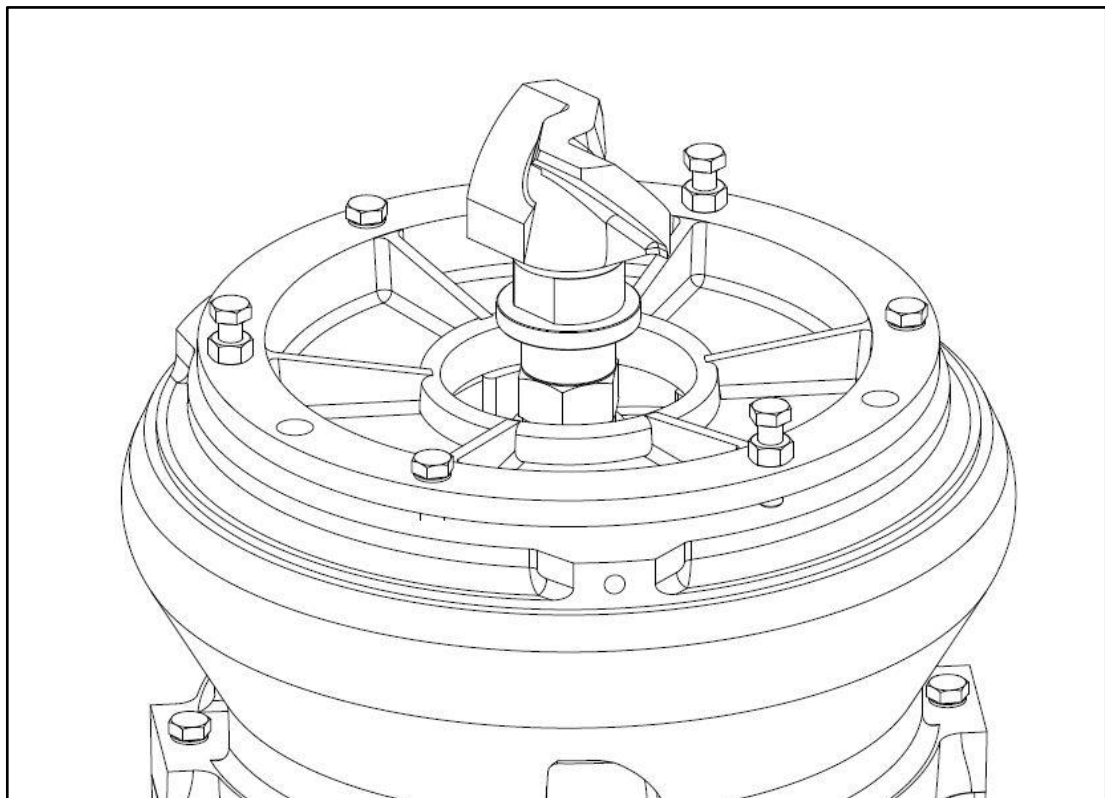
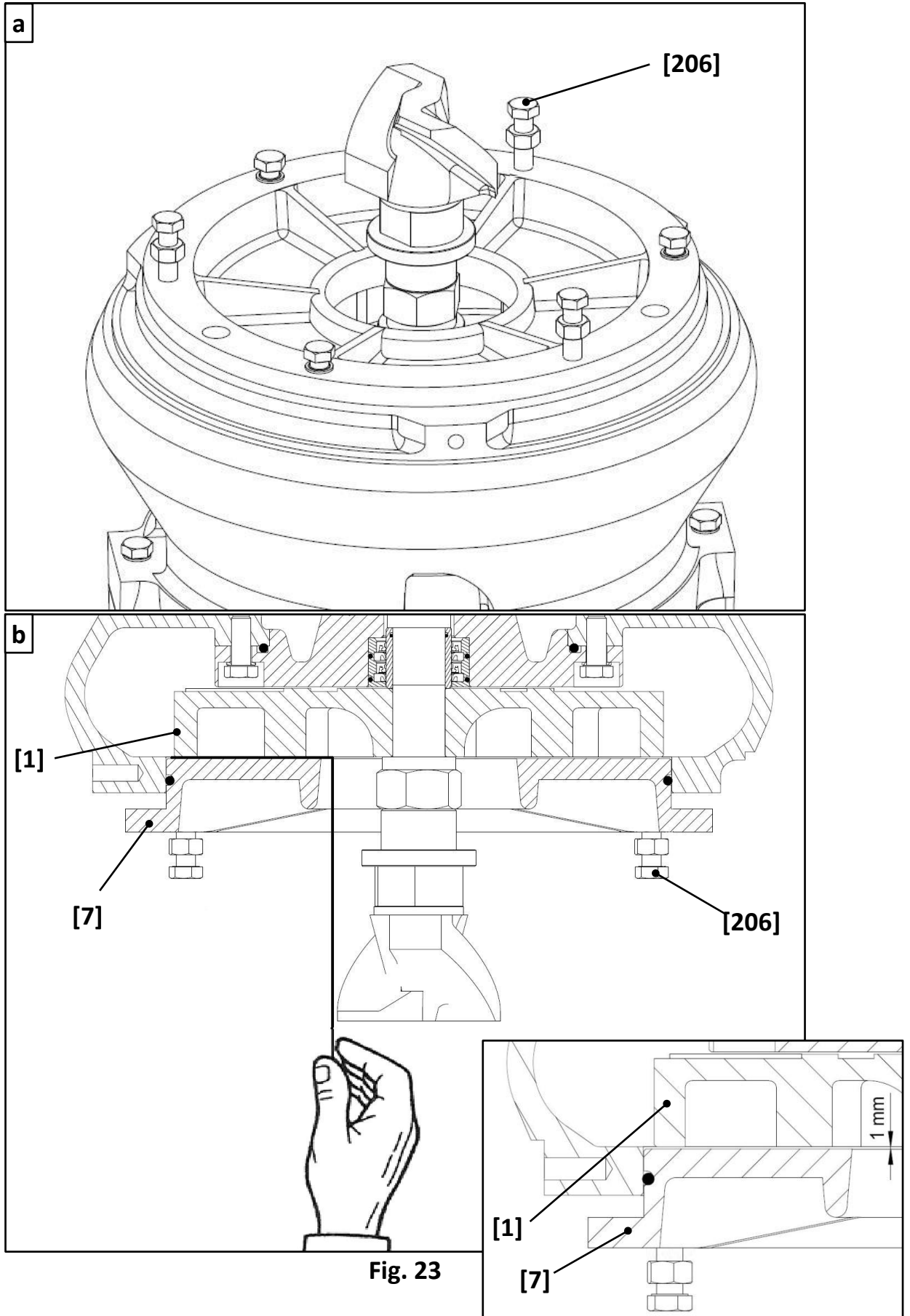

Fig. 22



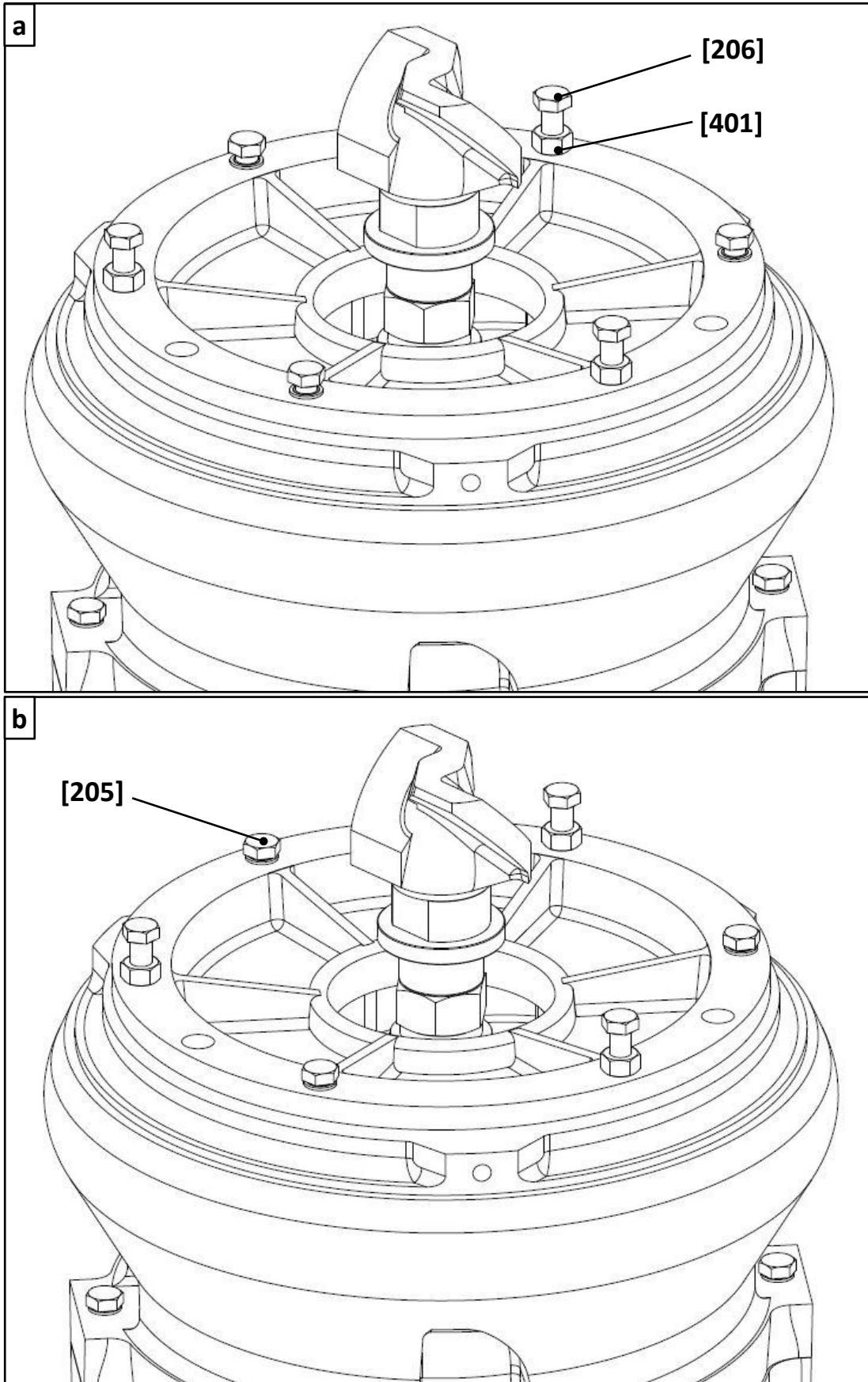



Fig. 24

5.4 Maintenance replacing instructions

The pump has components requiring a periodical replacing due to wearing and performance loosing and depending on the working conditions.

The replacing of all these components must be executed following a correct sequence of instructions and some of their replacing can be performed only after other previous disassembling.

See below a table with the correct prelimineries disassembling sequence in order to replace a certain component:

REPLACING DISASSEMBLING	SEE SECTION	DISASSEMBLING SEQUENCE		
Power cable	5.4.1*			
Strainer	5.4.2			
Lower wear plate	5.4.3	5.4.2		
Agitator kit	5.4.4	5.4.2		
Impeller	5.4.5	5.4.3	5.4.4	
Motor bearing	5.4.6*			
<p><i>BEFORE THE FOLLOWING OPERATIONS, COMPLETELY EMPTY THE PUMP OF THE OIL (SEE SECTION 5.3.2)</i></p>				
		<p><i>Avoid to pollute the environment with the exhausted oil dispersion. Collect and dispose it in conformity with the local laws.</i></p>		
Lower seals	5.4.7*	5.4.5		
Mechanical seals	5.4.8*	5.4.7*		
Upper bearings	5.4.9*	5.4.6*	5.4.8*	

Any replacing maintenance with the * symbol must be performed by the manufacturer Service Department or by a skilled mechanical operator following the instructions given by the Service Manual, available on request.

5.4.1 Power cable

Call the Service Department or see the Service Manual.

5.4.2 Strainer

For the strainer removing, follows the instructions listed below:

- place the pump vertically and overturned in a stable and safe condition;
- remove the n°3 bolts [207] and related washers [300] (see Fig. 25);
- handly rotate the agitator [10] so as to fit with the through hole of the strainer (see Fig. 26a);
- remove the strainer [50] (see Fig. 26b).

Reassemble all the components in reverse order to restore the pump at the initial conditions. Before reassembling, check the good conditions of any bolt and eventually replace the damaged ones.

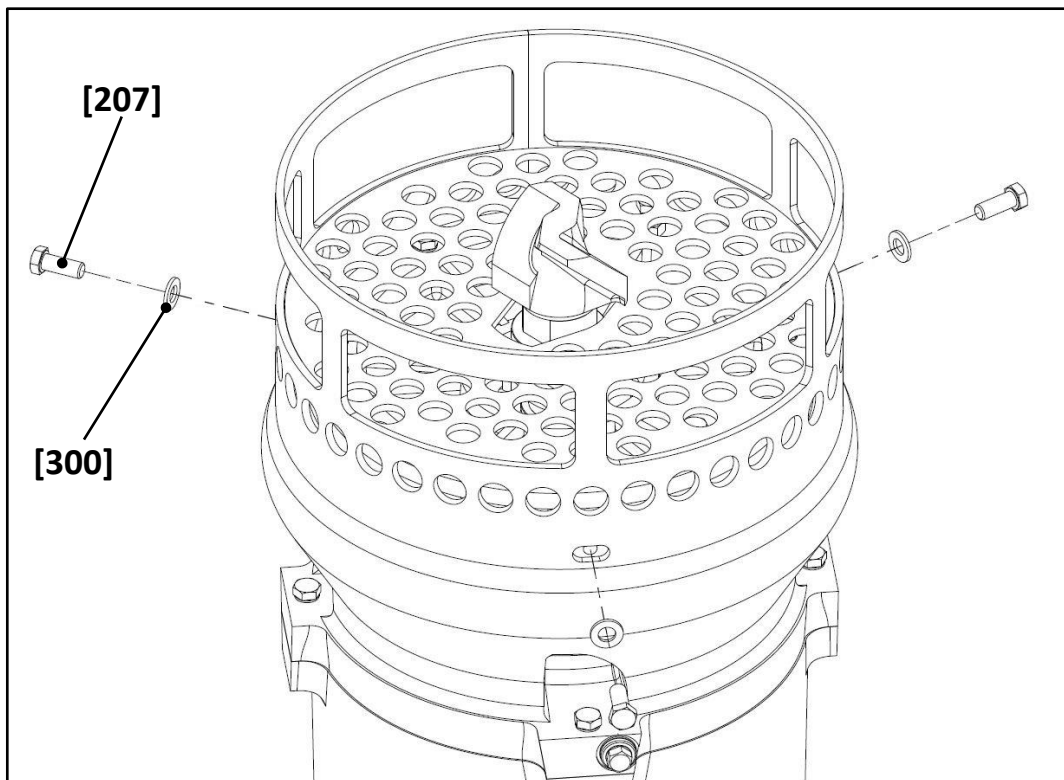

Fig. 25

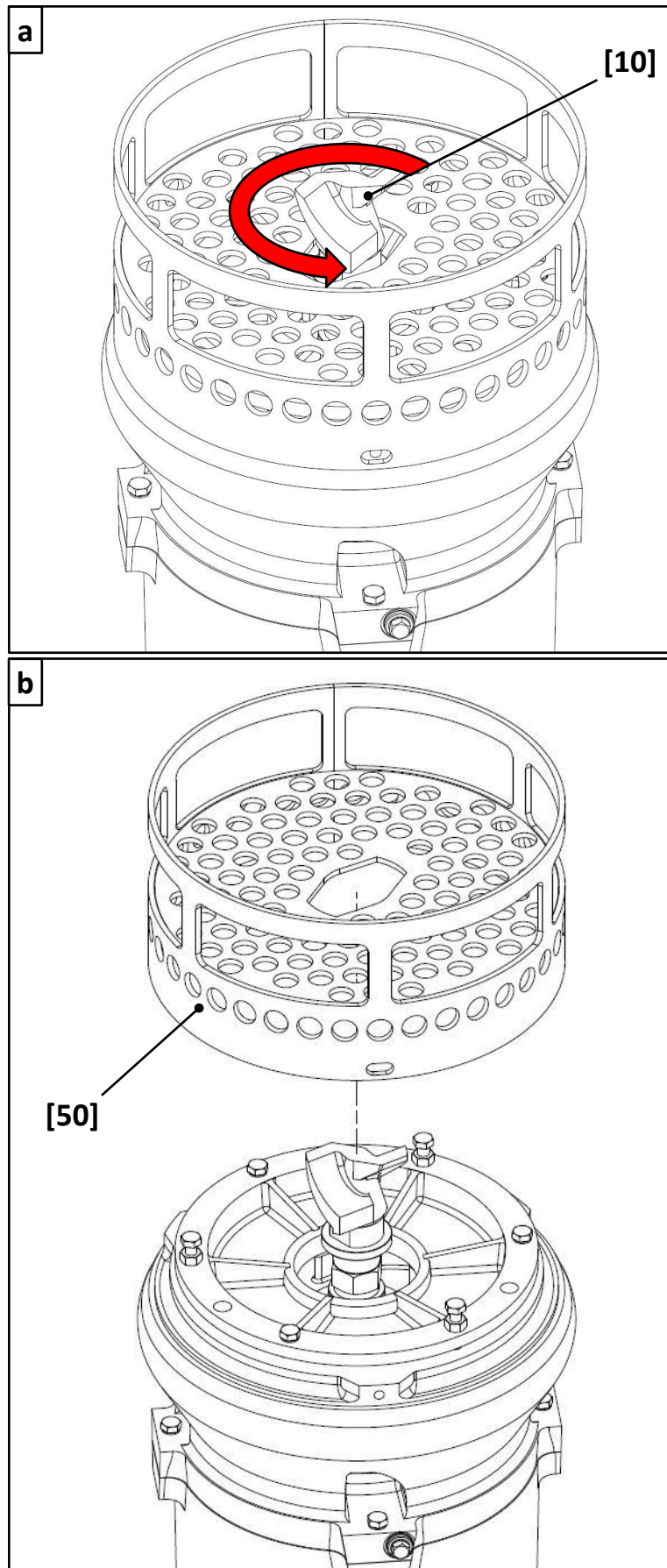

Fig. 26

5.4.3 Lower wear plate

Refer to the table in the **Maintenance replacing instructions** section for the previous disassembling sequence.

Subsequently, follow the instructions listed below:

- place the pump vertically and overturned in a stable and safe condition;
- remove the n°3 bolts **[205]** and related seal washers **[351]** (see **Fig. 27**);
- release the n°3 nuts **[401]** of the adjusting bolts and slightly tight each adjusting bolt **[206]** to help the lower wear plate **[7]** extraction (see **Fig. 28a** and **Fig. 28b**);
- remove the lower wear plate **[7]** and the O-ring **[90]** (see **Fig. 28c**).

Reassemble all the components in reverse order to restore the pump at the initial conditions. Before reassembling, check the good conditions of any bolt and eventually replace the damaged ones.

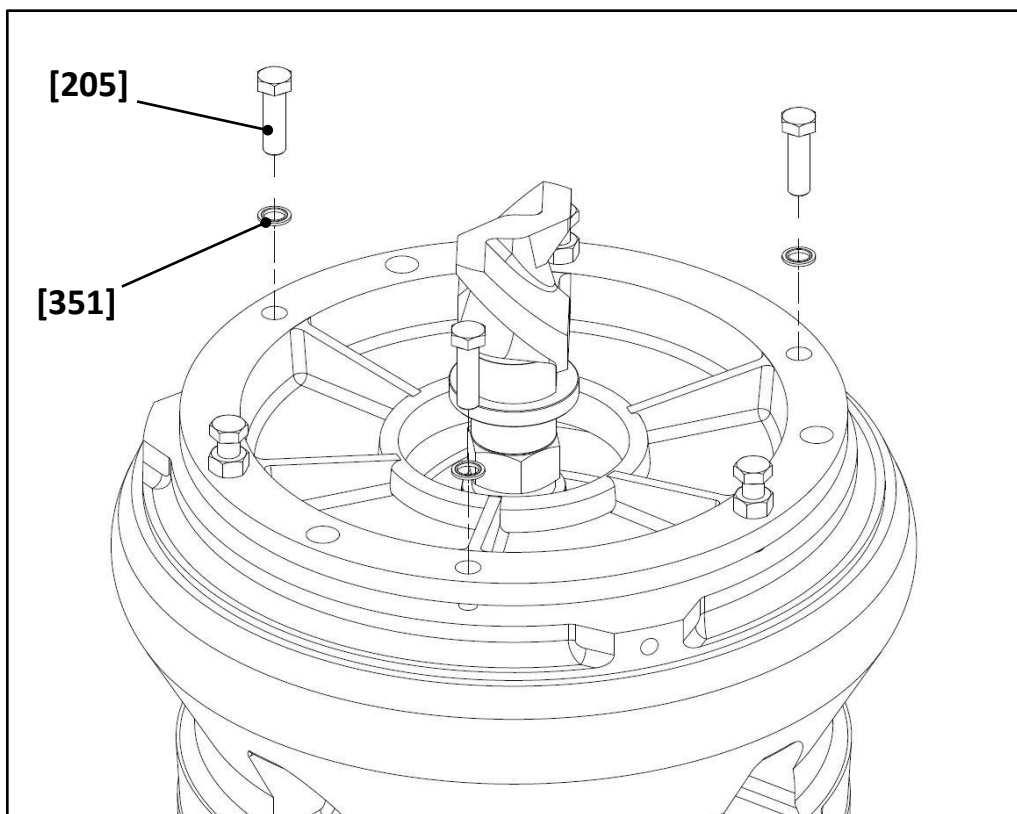

Fig. 27

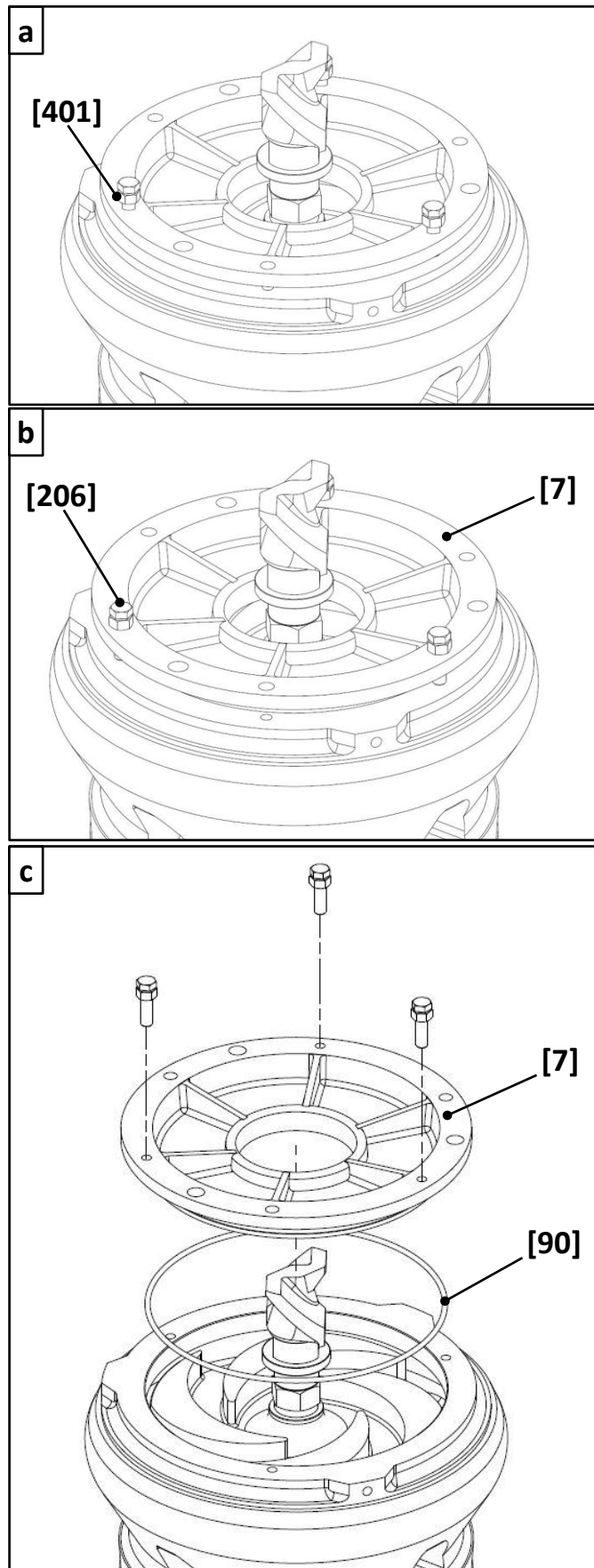

Fig. 28

5.4.4 Agitator kit

Refer to the table in the **Maintenance replacing instructions** section for the previous disassembling sequence.

Subsequently, follow the instructions listed below:

- place the pump vertically and overturned in a stable and safe condition;
- maintaining blocked the impeller (e. g. by inserting an iron rod), unscrew the agitator [10] by hitting smartly in counterclockwise direction with a hammer (see Fig. 29);
- after removing the agitator, unscrew the connector [11], the nut [12] and remove the spacer [13] directly installed on the main shaft [2] (see Fig. 29a and Fig. 29b).

Reassemble all the components in reverse order to restore the pump at the initial conditions. Before reassembling, check the good conditions of any bolt and eventually replace the damaged ones.

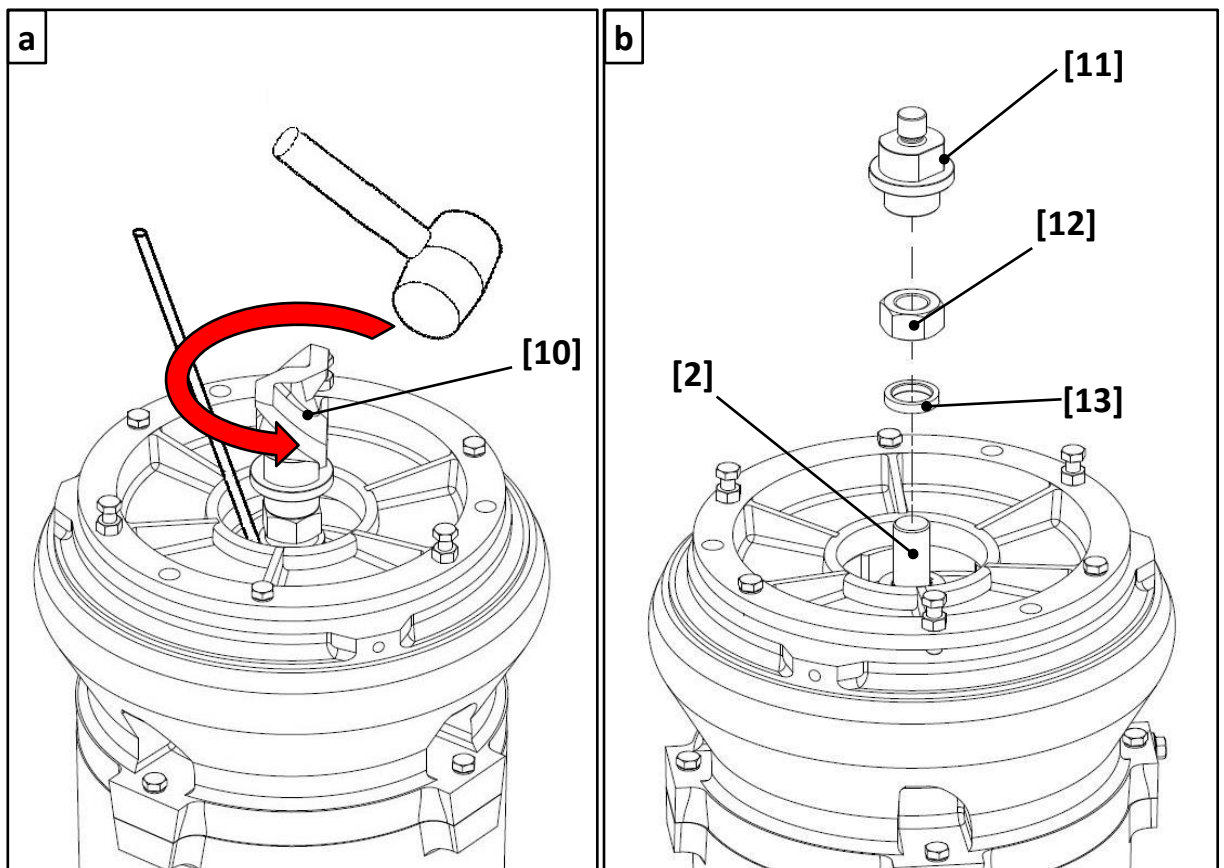

Fig. 29

5.4.5 Impeller

Refer to the table in the **Maintenance replacing instructions** section for the previous disassembling sequence.

Subsequently, follow the instructions listed below:

- place the pump vertically and overturned in a stable and safe condition;
- remove the impeller [1] and the key [503] from the shaft [2] (see Fig. 30).

Reassemble all the components in reverse order to restore the pump at the initial conditions. Before reassembling, check the good conditions of any bolt and eventually replace the damaged ones.

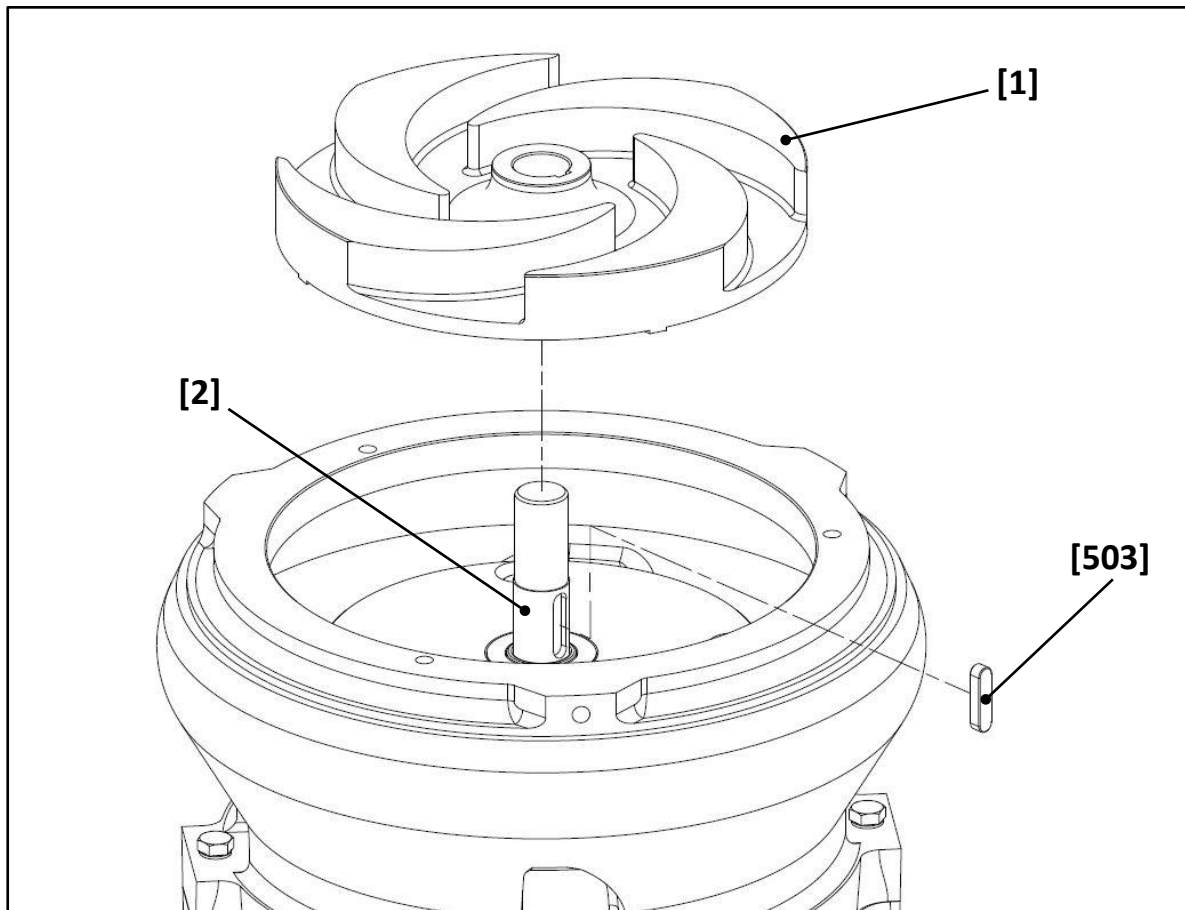

Fig. 30

5.4.6 Motor bearing

Call the Service Department or see the Service Manual.

5.4.7 Lower seals

Call the Service Department or see the Service Manual.

5.4.8 Mechanical seals

Call the Service Department or see the Service Manual.

5.4.9 Upper bearings

Call the Service Department or see the Service Manual.

5.4.10 O-ring replacing

It's good practice to replace any O-ring disassembled during maintenance operation, even if it seems in good conditions.

When a O-ring must be replaced, lubricate it and carefully clean its seat before positioning.

6 Optional devices

The pump can be equipped with some optional device increasing its performance or making it more suitable for specific use.

Refer to the following optional devices list for a brief description and for the required spares, taking care to some item that could replace the one installed on the default configuration of the pump.

6.1 Jet-ring system

The jet-ring system is a optional device that help the dredging pump to move the solids underwater creating the mixture more efficiently due to a well oriented jet of clean water. It consist of a tubular frame fixed on the strainer and equipped with a threaded inlet (1" ¼ G female) and several outlet nozzles suitably oriented to the dredging area. The jet-system requires a water in pressure supply (by a water pump and piping) with at least these working performances:

- water pressure: 8 bar
- water flow rate: 20 mc/h.

6.1.1 Spare parts

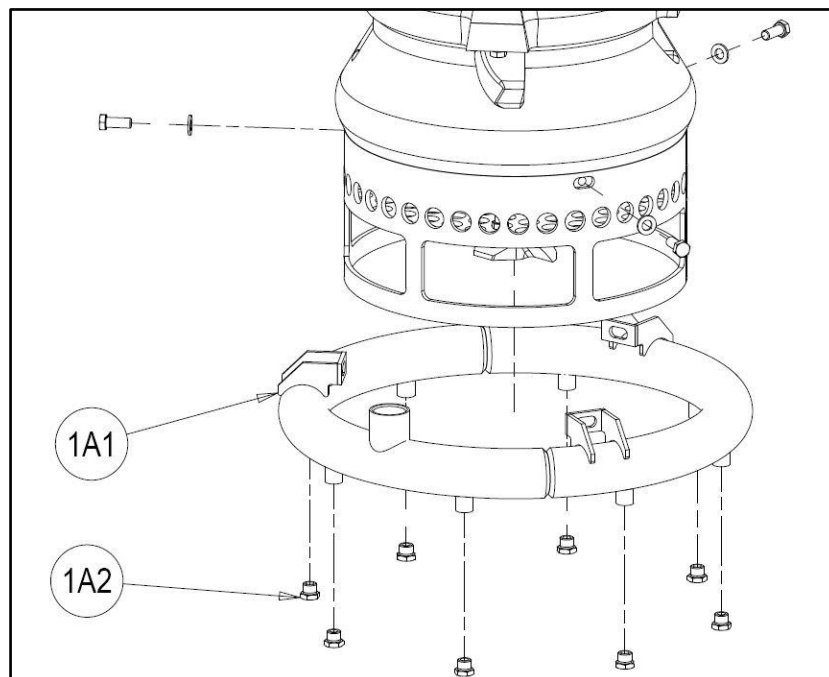

Fig. 31

POS.	Q.TY	PART NUMBER	DESCRIPTION	REPLACE POS./NR.
1A1	1	F54259	JET-RING FRAME	-
1A2	8	A7001193 (*)	NOZZLE	-

6.2 Compensation system

The compensation system is an optional device required when the pump works underwater with a depth greater than 25 meters.

It consists of a protected rubber bag filled with oil transferring the hydrostatic pressure inside the pump and keeping balanced the inner and outer pressure between the pump sealing system. The oil must have the same properties of the suggested lubricating oil (see **Lubricant specifications** in the Maintenance section).

6.2.1 Spare parts

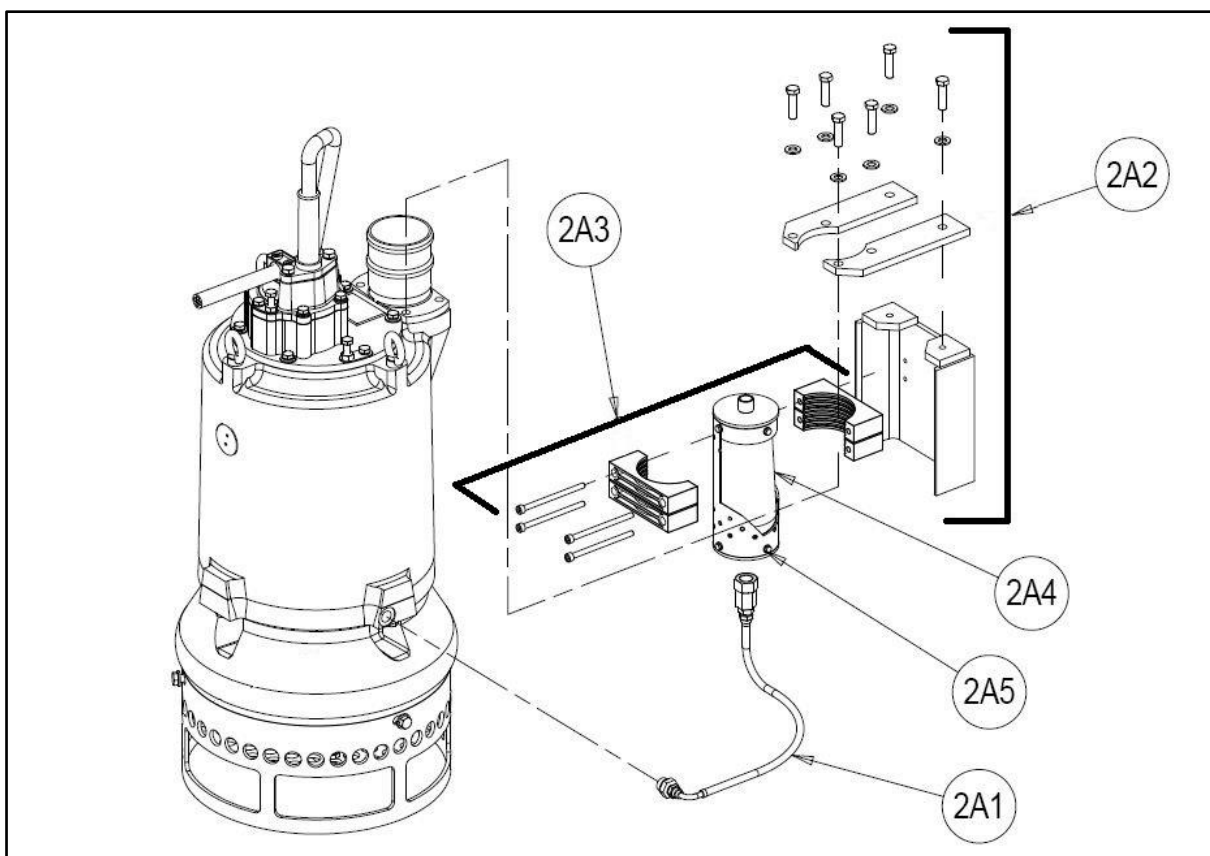

Fig. 32

POS.	Q.TY	PART NUMBER	DESCRIPTION	REPLACE POS./NR.
2A1	1	160909	OIL HOSE	-
2A2	1	162024	BRACKET	-
2A3	2	160910	CLIP	-
2A4	1	A7006193/2 (*)	RUBBER BAG	-
2A5	1	G54226/3	CYLINDER	-

6.2.2 Additional maintenance for compensated pump

For any compensated pump, the lubricating oil check must be performed before any shift in order to ensure that the rubber bag is completely filled and the compensation works properly. With the same activity, the rubber bag conditions and the lubricating oil quality could be verified.

For the oil checking inside the rubber bag, disassemble the compensator as per the following instructions:

- open each clip [2A3] by unscrewing its n°2 bolts [A] (Fig. 33a);

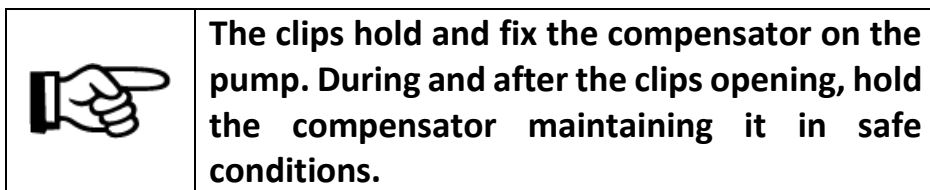

- unscrew the n° 4 bolts and washers [C] and open the lower cover [B] of the cylinder [2A5] (Fig. 33b);
- remove the rubber bag [2A4] from the cylinder [2A5] (Fig. 33c) and check the lubricating oil quantity inside it by unscrewing the fitting [D] with the copper washer [E] of the hose [2A1] (Fig. 33d);

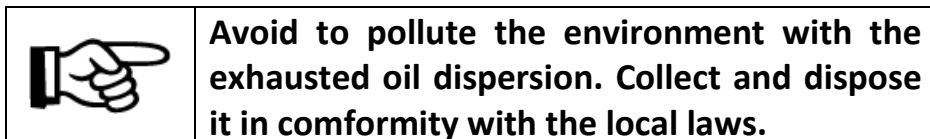

- if the rubber bag is not completely full, refill it with the suggested lubricating oil (see **Lubricants specifications** in the Maintenance section).

Reassemble all the components in reverse order to restore the initial conditions. Before reassembling, check the good conditions of any bolt and sealing component and eventually replace the damaged ones.

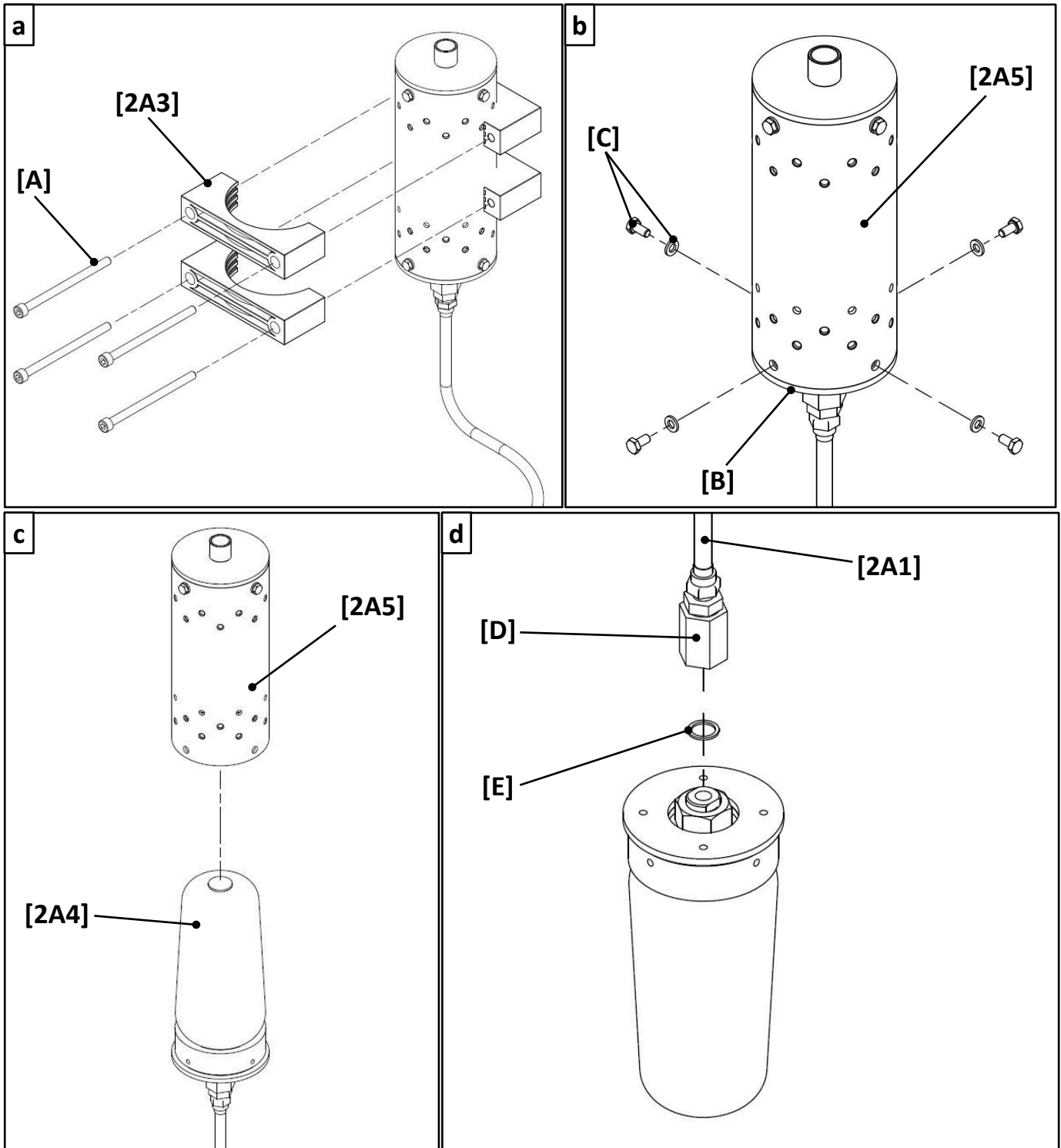

Fig. 33

6.3 Temperature sensor

The temperature sensor is an optional device required for the working temperature control of the pump in order to stop it, if suitably wired, when the temperature exceeds a specified set-point value (default 150°C).

6.3.1 Spare parts

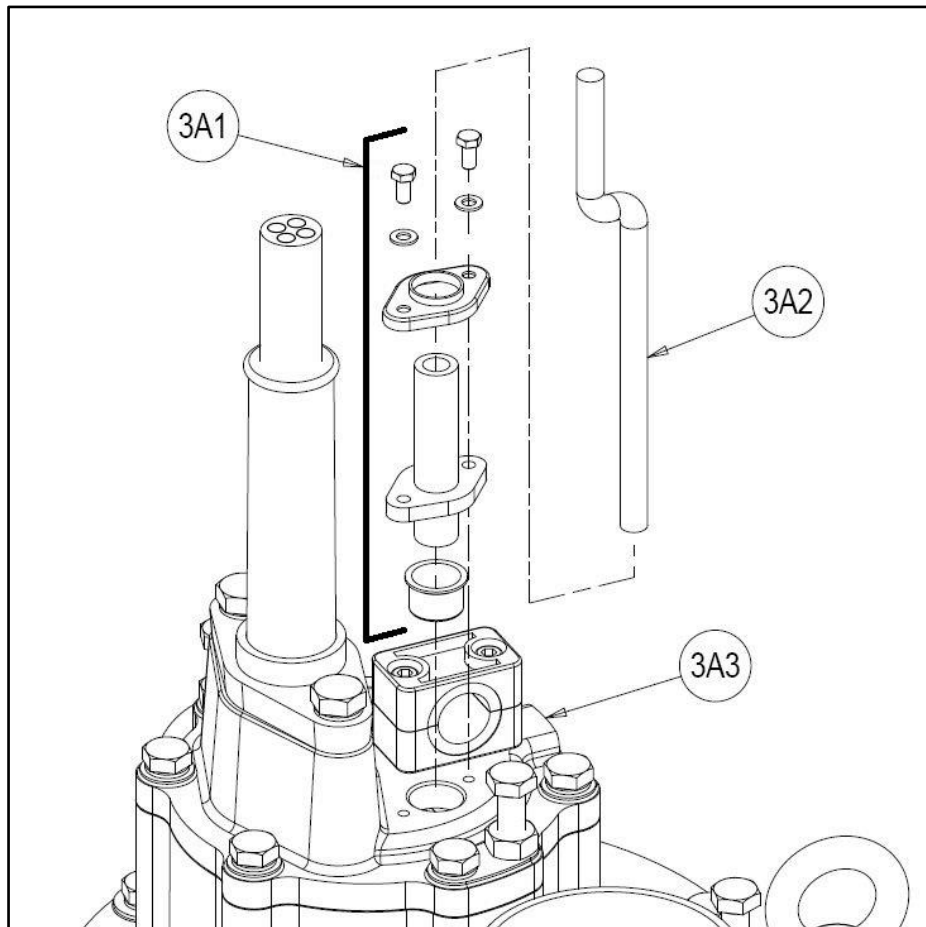

Fig. 34

POS.	Q.TY	PART NUMBER	DESCRIPTION	REPLACE POS./NR.
3A1	1	A3003394	SIGNAL CABLE GLAND	-
3A2	20	A3004088 (*)	SIGNAL CABLE (default 20 m)	-
3A3	1	160714 (^)	UPPER INSPECTION COVER	40 / F21202

(^) Any pump changeover to a temperature controlled type requires a different upper inspection cover than the default one. See the SERVICE MANUAL for the cover replacing instructions.

6.4 Water sensor

Not available

6.5 Cooling jacket

Not available

6.6 Cutter knife

The cutter knife is an optional device installed on the main shaft and replacing the connector. Its purpose is to cut and minimize the dimension of some kind of solids (typically soft/fibrous wood pieces, seaweed and similar).

6.6.1 Spare parts

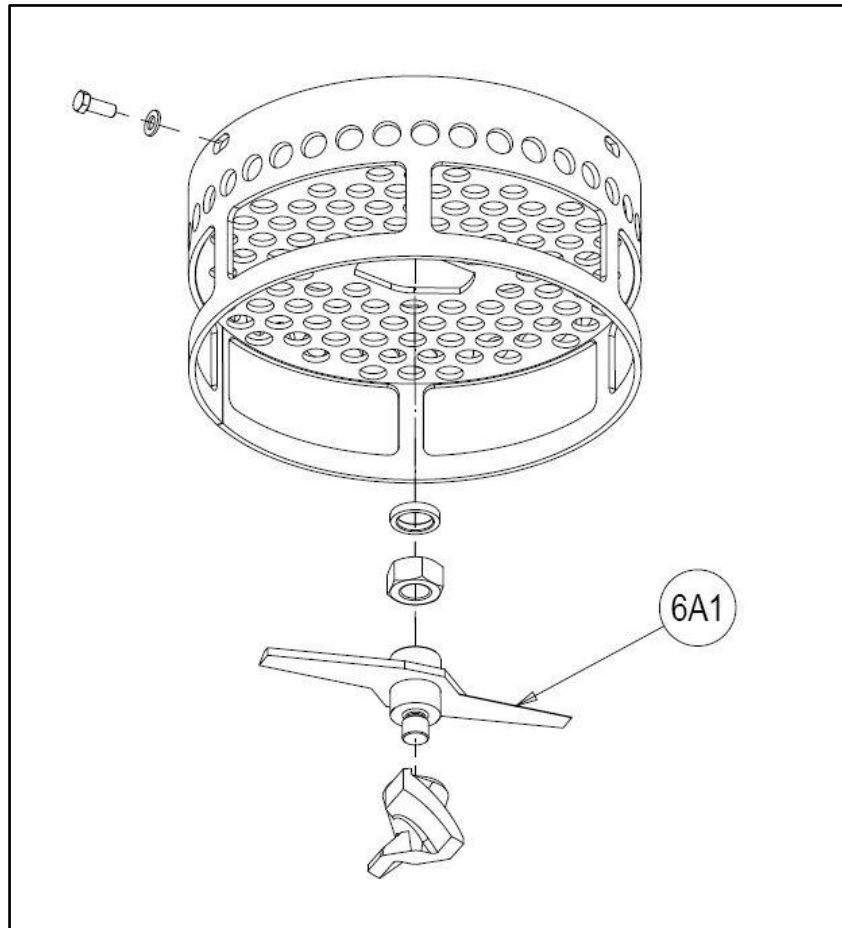

Fig. 35

POS.	Q.TY	PART NUMBER	DESCRIPTION	REPLACE POS./NR.
6A1	1	F39201 (*)	CUTTER KNIFE	11 / F21204

6.7 Aggressive environment kit

The aggressive environment kit is an optional configuration of the pump suitable for work in aggressive (chemically or thermally) conditions.

6.7.1 Spare parts

POS.	Q.TY	PART NUMBER	DESCRIPTION	REPLACE POS./NR.
7A1	2	A6503010 (*) (^)	SEAL	61 / F39288
7A2	1	A6503007 (*) (^)	SEAL	62 / A6503030
7A3	3	A2517011	EYEBOLT	141 / A2517002
7A4	1	A6001020	PLUG	170 / A6504065
7A5	12	A2501248	BOLT TE M10x30	200 / A2501005
7A6	4	A2501256	BOLT TE M10x40	201 / A2501013
7A7	13	A2501237	BOLT TE M12x30	202 / A2501028
7A8	4	A2501159	BOLT TE M12x50	204 / A2501018
7A9	3	A2527063	BOLT TE M12x40	205 / A2501016
7A10	3	A2501179	BOLT TE M12x45	206 / A2501049
7A11	7	A2527043	WASHER M12	300 / A2510003
7A12	12	A2527017VITON	SEAL WASHER M10	350 / A2527016
7A13	16	A2527072VITON	SEAL WASHER M12	351 / A2527018
7A14	1	A6503042	SEAL WASHER	180 / A1504019
7A15	4	A2501234	NUT M10	400 / A2508005
7A16	3	A2509012	NUT M12	401 / A2508012
7A17	1	161065 (*)	AGITATOR CONNECTOR	11 / F21204
7A18	1	A2509006 (*)	AGITATOR NUT	12 / A2508027
7A19	1	F0155634 (*)	AGITATOR SPACER	13 / F21215

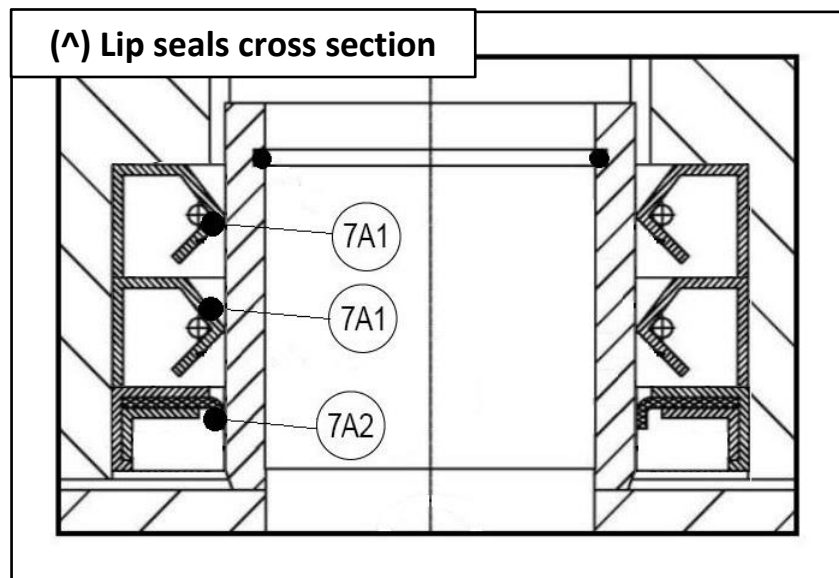

Fig. 36

(^) Any pump changeover to an aggressive environment resistant type requires a different lip seals pack than the default one. See the SERVICE MANUAL for the lip seals pack replacing instructions.

6.8 Waterflush kit

Not available

6.9 Remote greasing kit

Not available

6.10 Optional on this pump

See below the optional on this pump:

N°	DESCRIPTION	ON THIS PUMP	
		YES	N/A
1	Jet-ring system	✗	
2	Compensation system	✗	
3	Temperature sensor	✗	
4	Water sensor		✗
5	Cooling jacket		✗
6	Cutter knife	✗	
7	Aggressive environment kit	✗	
8	Waterflush kit		✗
9	Remote greasing kit		✗

7 Attachments

7.1 Data sheet and performance curves (*see next pages*)