

Spare Parts Catalogue

E6500

Power systems | Generating sets

Valid for machine code: PA482SYH000

Revision: 0 (12/2006)

Copyright 2016 Pramac Group, All Rights Reserved.

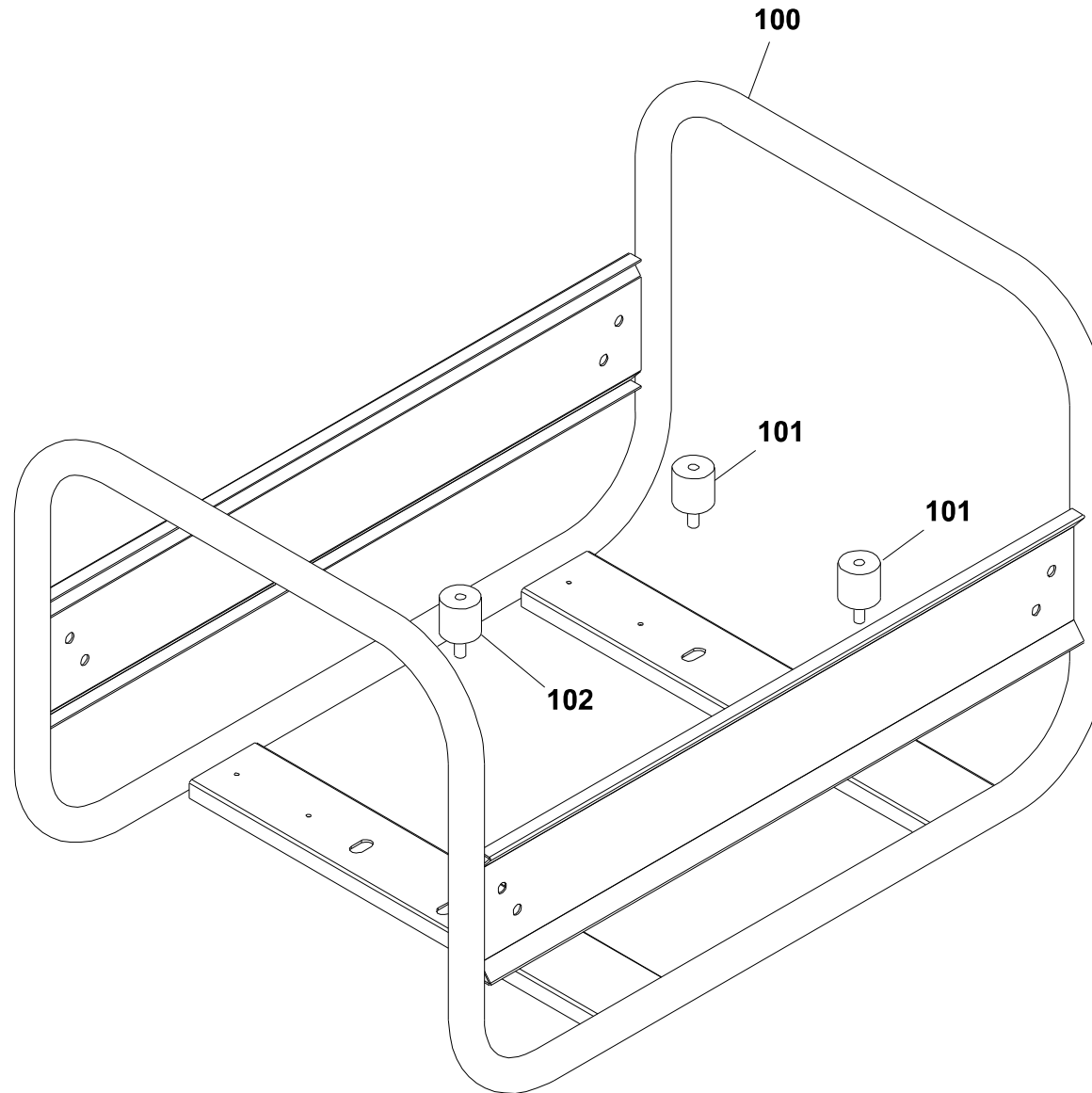

Position	Part Number	Description	Notes
100	▲ VA50017600-PRAMACB	E6000/4500 Tubular Frame Painted * Pramac Orangepeel	Valid for products manufactured from 07/01/2009
	▲ V72520001-PRAMACB	Compl. Frame E6000tyhdi Painted	Valid for products manufactured until 07/01/2009
101	G052112	Cylindric Silent-block Mf-30x30-m8x15-m8-60	-
102	G052118	Use G052183	-

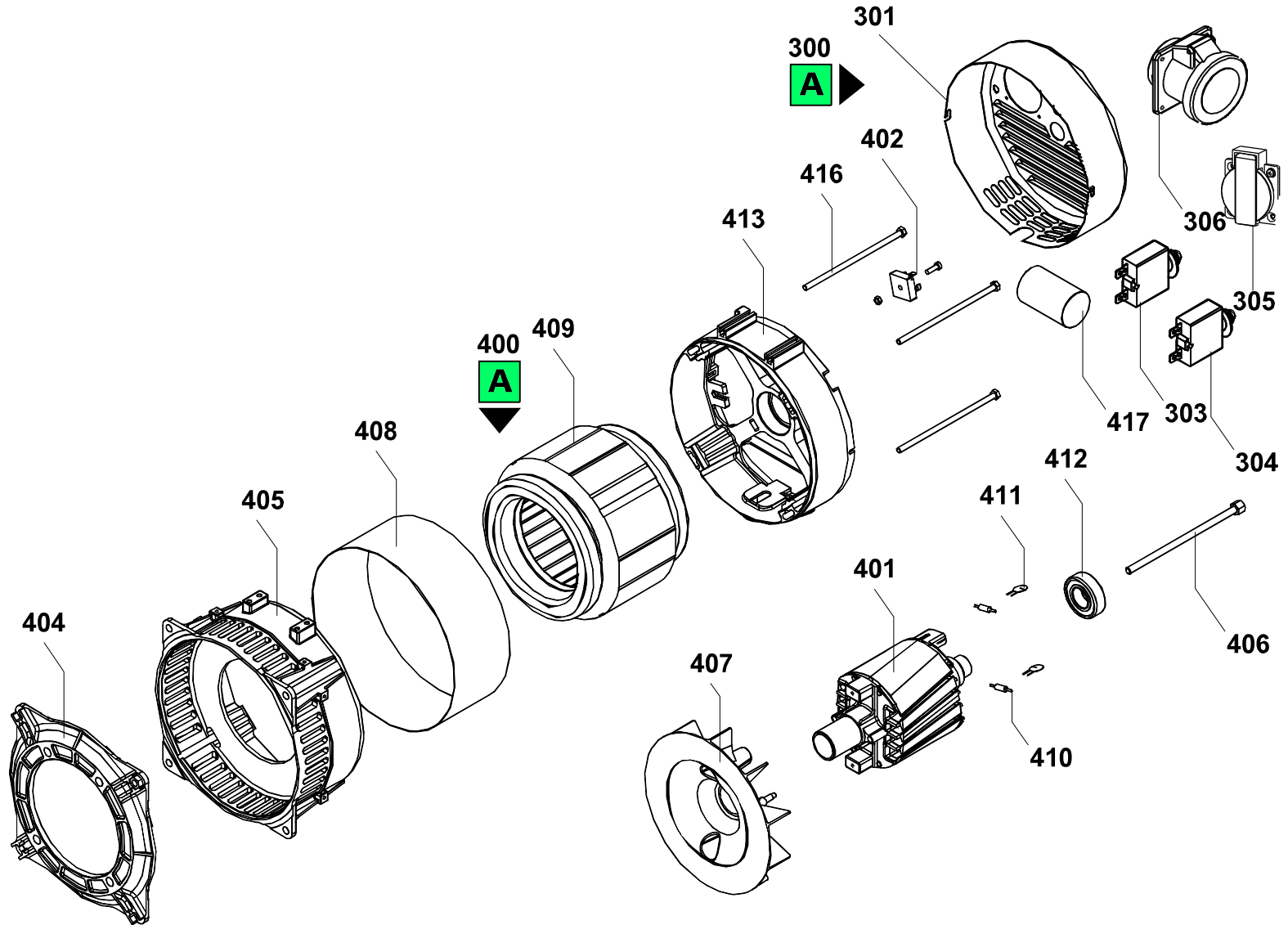

Position	Part Number	Description	Notes
300	PAM0391702710	Cover 1schuko+1cee32a+2thermal Switch	-
303	G075533	Switch Us 15 A 250v	-
304	G075534	Thermal Circuit Breaker 30a 250v	-
305	G071131	Socket Subassembly, Power Supply	-
306	G071129	Panel Mount Socket 2p+t 230v 32a Ip44 Cee	-
400	AMS5500CB0ADBZ	Alt. Ar2 90 5,5/115/230/50/3000 J609b	-
404	PAM0390600175	Flange Alt. Ar2 J609b - S20w	-
405	PAM0391700333	Cover Ar2	-
406	PAM0391800342	Central Tension Rod Ar2 5,5kva J609b	-
407	PAM0392000039	Fan Ar2/110	-
408	PAM0390601049	Shutter Band Ar2 5,5 Kva	-
409	PAM0391702000	Stator Ar2/90 5.5/115/230/50/3000	-
410	PAM9910356050	Diode D2/125 25a	-
411	G70459	Varistor Z-10-l-561	-
412	G70704	Rear Bearing 6205-2z	-
413	PAM0390302222	Alt. Front Cover Ar2/110	-
416	PAM0391800294	Side Tension Rod Ar2 5,5kva	-
417	G079102	Capacitor 35uf 450v	-

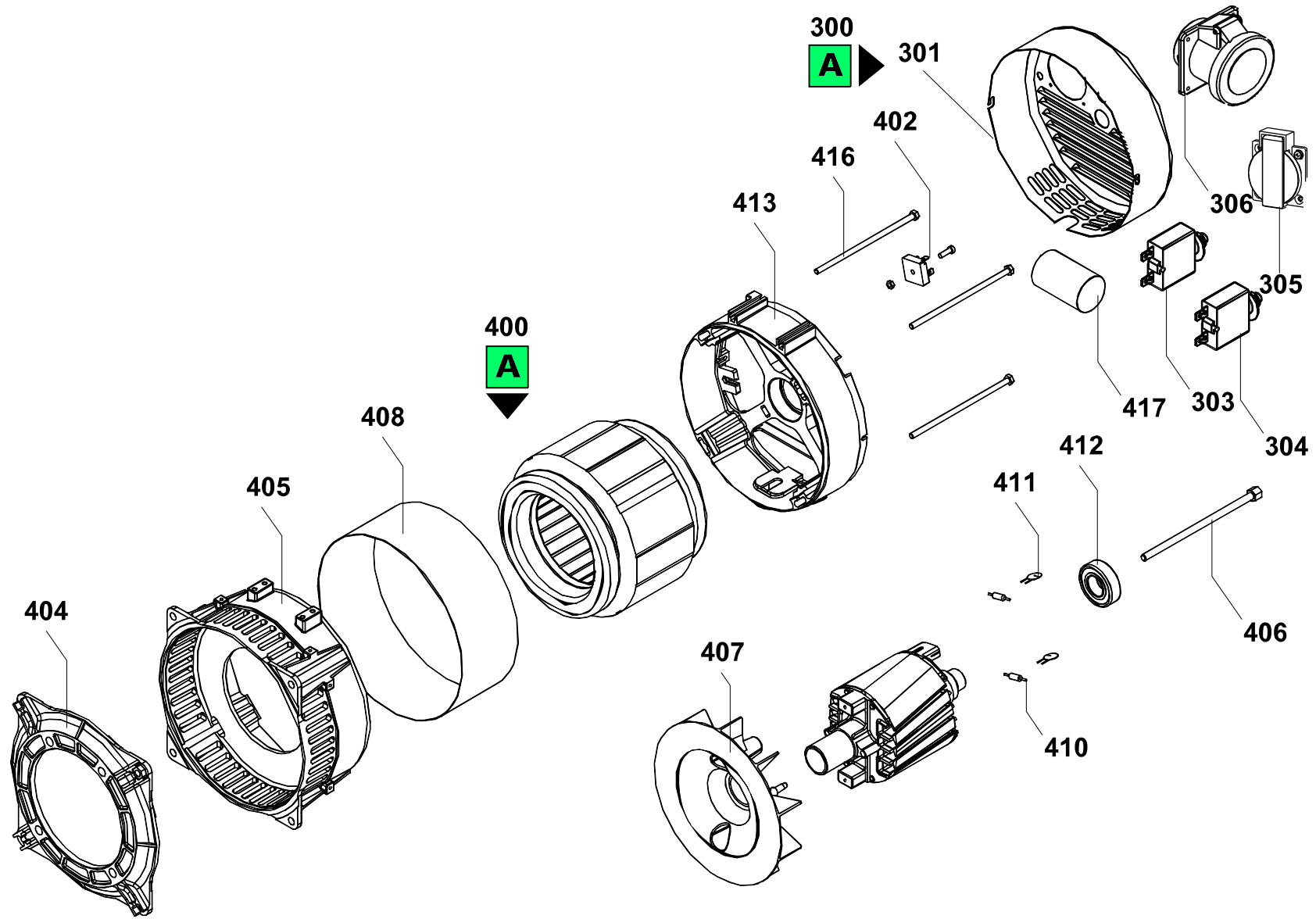

Position	Part Number	Description	Notes
300	PAM00015	Cover S16w 130 - 1 Schuko + 1 Cee 32a + 2 Circuit Breaker - Ip23	-
303	G075533	Switch Us 15 A 250v	-
304	PAM00040	Disgiuntore Termico 22a	-
305	G071131	Socket Subassembly, Power Supply	-
306	G071129	Panel Mount Socket 2p+t 230v 32a Ip44 Cee	-
400	AMS5000CB0ADBZ	Alternator S16w-130/a 5/115/230/50/3000 J609b	-
402	PAM0391400607	Rectifying Diode Bridge Mf (skb25-08)	-
404	PAM00027	Flangia S16w J609b	-
405	PAM0391700153	Drive End Bracket Ip23 S16w/a	-
407	PAM0392000015	Fan S16w	-
408	PAM0390601043	Locking Band S16w 5kva	-
410	PAM0390400015	Diodo 10a 1200v	-
411	G70459	Varistor Z-10-l-561	-
412	G010301	Bearing 6203 2z (17-40-12)	-
413	PAM0390302209	Non-drive End Bracket	-
416	PAM0391800323	-	-
417	G70113	Capacitor 25 Uf M1 Kva 5	-

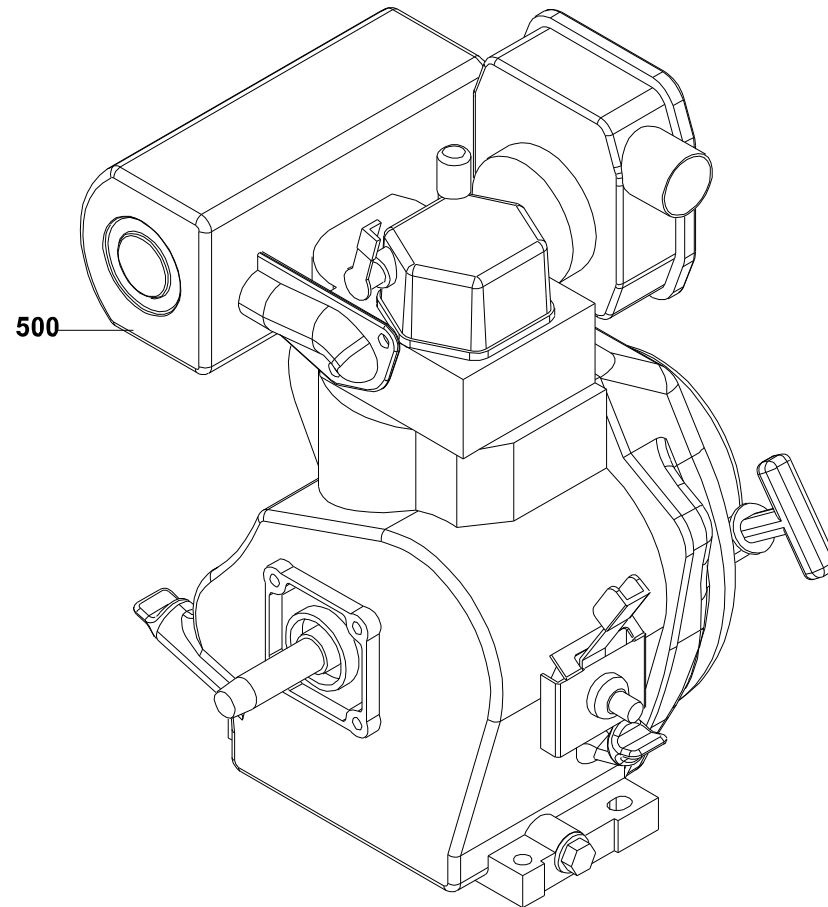
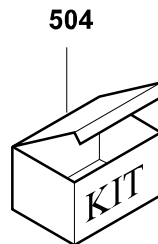
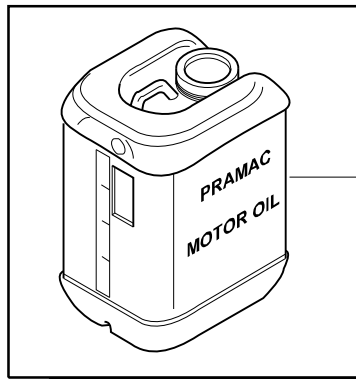
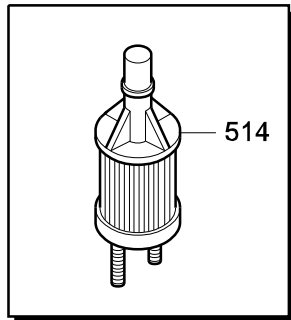
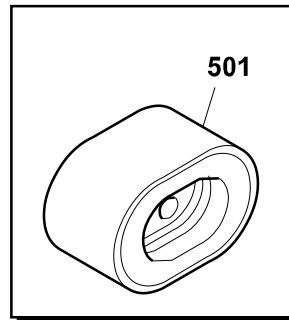
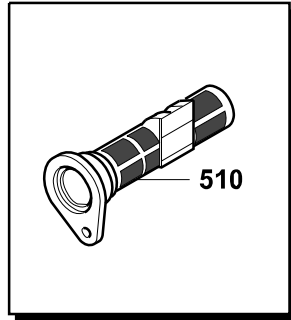

Position	Part Number	Description	Notes
500	▲ EYP100BBY7Z	Engine Yanmar L100 Air_3000_mech_j609b-_handstart__ver/sp:l100n5ef1c1ja	Valid for products manufactured from 03/06/2009
	▲ EYP100BBK7Z	Engine Yanmar L100 Air_3000_mech_j609b-_handstart__ver/sp:l100ae-dgmsyc	Valid for products manufactured until 03/06/2009
501	▲ PEY00015	Air Filter	Valid for products manufactured from 03/06/2009
	▲ PEY00002	Air Filter	Valid for products manufactured until 03/06/2009
504	▲ P3KI00109	Maintenance Kit S4500 E4500-e6500-e6000-s6500-s6000-w180-wp180	Valid for products manufactured from 03/06/2009
	▲ P3KI00011	Maintenance Kit E6000-p6000-e6500	Valid for products manufactured until 03/06/2009
510	PEY00005	Oil Filter	-
514	PEY00006	Gasoil Filter L100	-