

## Spare Parts Catalogue

# S8000-2015-THREEPHASE-

Power systems | Generating sets

Valid for machine code: PD652THBZ04

Revision: 0 (9/2015)

Copyright 2016 Pramac Group, All Rights Reserved.

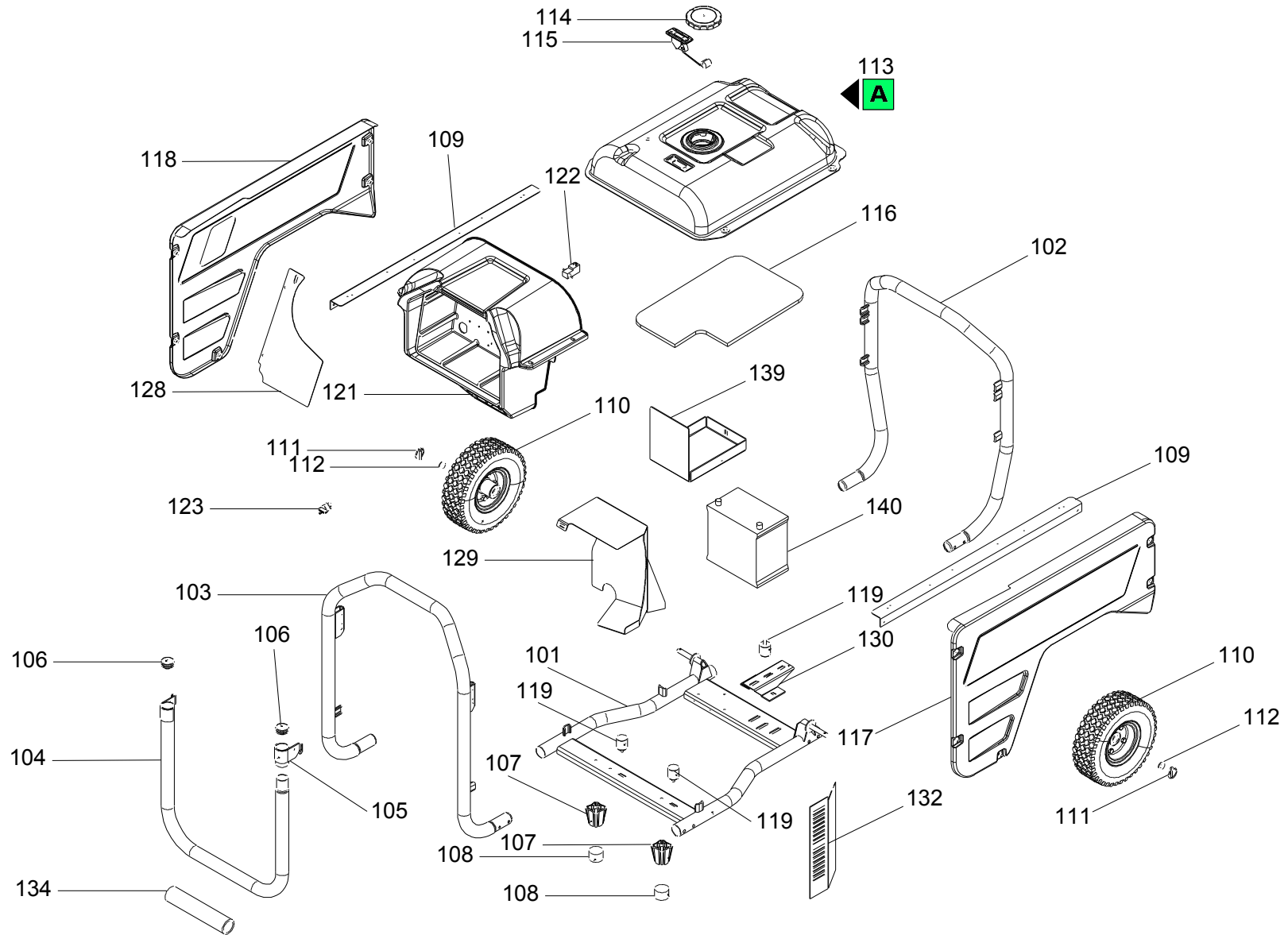

Position	Part Number	Description	Notes
101	VA40016040-9005B	Painted Central Part Of Multibody Frame	-
102	VA40016043-9005B	Painted Assembled Pipe Alternator, Multibody Frame	-
103	VA40016045-9005B	Painted Assembled Pipe Engine, Multibody Frame	-
104	VA40016049-9005B	Painted Assembled Carrying Handle	-
105	VA40016047-9005B	Painted Mobile Connection For Carrying Handle	-
106	G051519	Plastic Cap Ø 35 Black	-
107	GA7021	Feet Support +nut+screw	-
108	G052956	Rubber Feet 85 Sh-a	-
109	GA7032	Metal Sheet Support For 26,5 L Fuel Tank	-
110	G052444	Wheel 3,5"x10" Rubber Filled Flat Tread, Black Rim With Sphere Bearings	-
111	G44208	Bell Split Pin D4.5(p.n.115 Ama)	-
112	G041908	Plain Washer 6592 13x24 Zn	-
113	SA40016052	Fuel Tank With Supplements	-
114	G051521	Shell Fuel Cap For Metal Tank - Vent Holes On Top	-
115	G080307	Fuel Tank Gauge For Metal Tank Of 26,5 L	-
116	SA40021903	Termoisolante Protezione Serbatoio New S5000-s8000	-
117	VA40016700-PRAMACB	Painted Right For Multibody Frame	-
118	VA40016701-PRAMACB	Painted Left For Multibody Frame Painted	-
119	G052120	Cylindric Silent-block Mf-40x40-m8x14-m8-45	-
121	SA40016055	Control Panel Housing For S Series Restyling	-
122	G079016	Electrovalve Choke S5-8000 No Direct Action12vcc	-
123	G085104	Quarter Turn Fuel Valve	-
128	SA40016702	Carburator Conveyor	-
129	VA40016051-9005B	Muffler Conveyor Painted	-
130	GA7028	Alternator Support	-
131	SA40016703	K-kr100 Alternator Conveyor	-
132	SA40016053	T-tr100 Alternator Conveyor	-
134	G052008	Covering For Carrying Handle D.35 Mm	-
139	VA7076-9005B	Painted Battery Plate New Series S	-
140	G089001	Battery 26ah 12v Sealed - 205x132x185.5	-

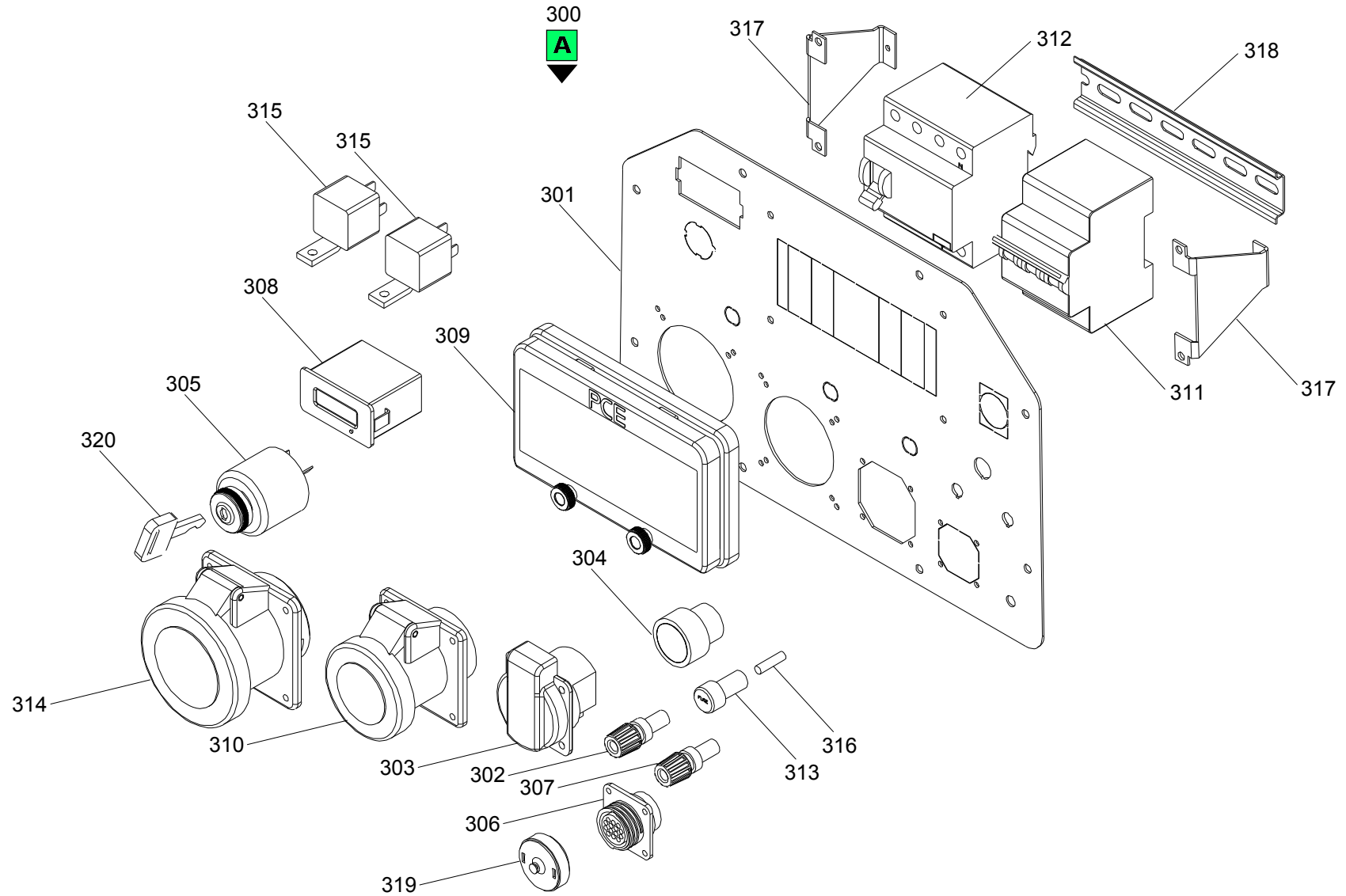

Position	Part Number	Description	Notes
300	SA40016967	New Control Panel S5000 Tp Conn +dpp Es - Ge0496	-
301	VA7039-9005	Metal Sheet For Control Panel New S Series Painted	-
302	G070109	Battery Charger Red Screw Terminal	-
303	G071131	Socket Subassembly, Power Supply	-
304	G075171	Black Push Button Not Illuminated For 22 Hole With Lock Nut	-
305	G075310	Starter Key Switch	-
306	G071021	Female Connector 14contacts Com. Dist.	-
307	G070110	Battery Charger Black Screw Terminal	-
308	G077014	Digital Multimeter Three Phase For Panel	-
309	G070312	Ip55 Cover 8 Modules Din	-
310	G071121	Panel Mount Socket 2p+t 230v 16a Ip44 Cee	-
311	G075540	Magnetothermic Switch 3p 10+10+16a	-
312	G075512	Differential Switch 4p 25a 0.03a	-
313	G070617	Panel Mount Fuse Holder 6a (5x20)	-
314	G071126	Panel Mount Socket 3p+n+t 400v 16a Ip44 Cee	-
315	G079583	Rele' 12v 1 30/20a 12.040.000	-
316	G070616	Fuse 10a 5x20 Glass	-
317	G070817	Sec. C Flask For Pr Bar	-
318	G070822	Omega Support 7,5x35	-
319	G071091	Sealing Cap With Bead Chain - 14 Poles Connector	-
320	G76926	Key Block Body For Starter Switch	-

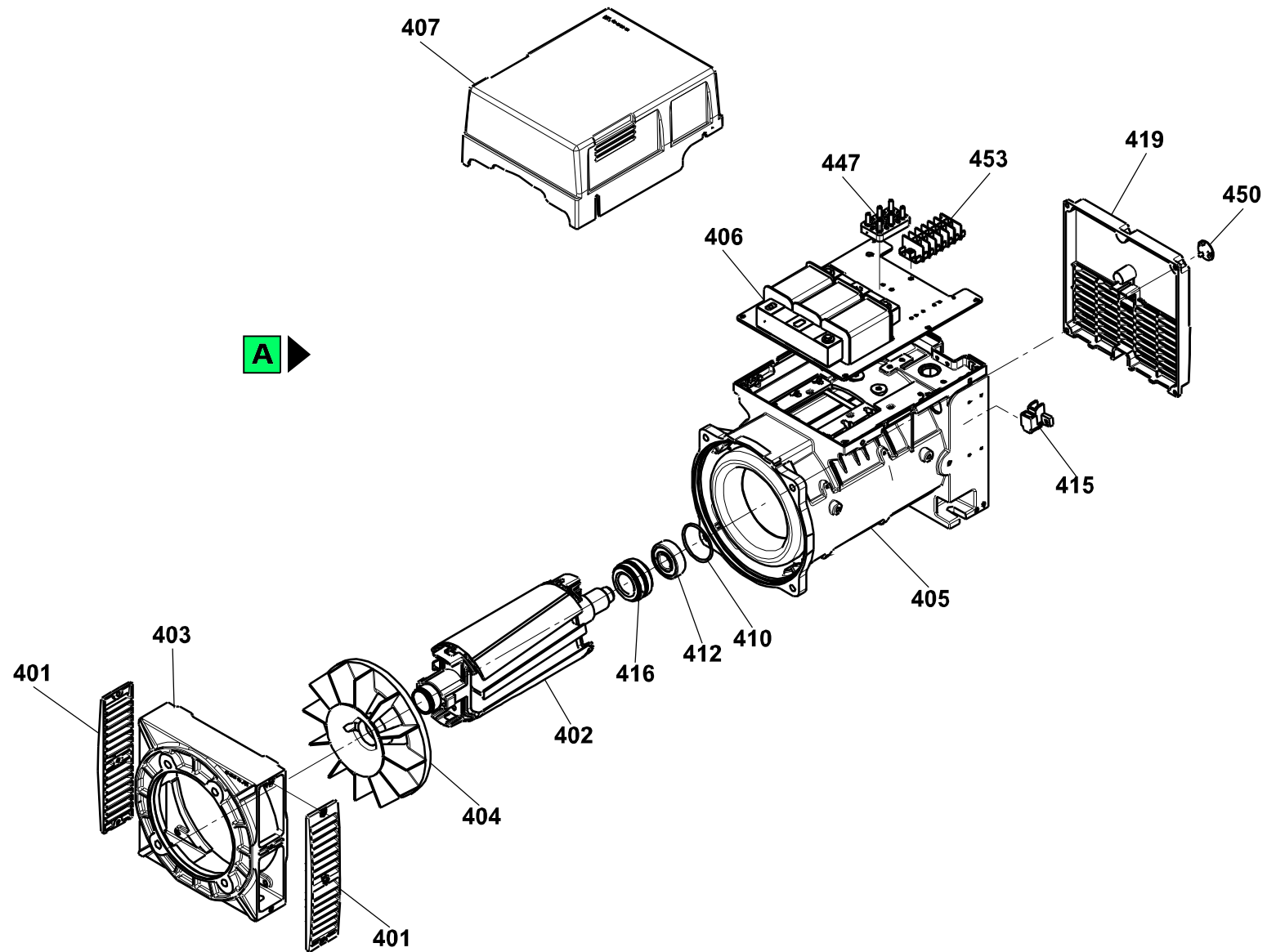

Position	Part Number	Description	Notes
400	AIT7000AB000XZ	Alt.t100sc 7,0/230/400/50/3000/12 J609b	-
401	PAN1GGA10010	Rete Di Protezione	-
402	PAN5AA121737	Rotore Completo Ait	-
403	PAN3SLA10012	Scudo Anteriore J609	-
404	PAN1VGA10003	Fan	-
405	PAN5FA120730	Carcassa Completa Ait	-
406	PAN5CA12033	Compound Completo Ait	-
407	PAN00018	Cover T100	-
410	G53518	Gasket Or 2187 D=1,78 De=47,35	-
412	G010409	Bearing 6204 2rs (20-47-14)	-
415	G70181	Brushes Set Eg3-a L=300	-
416	G70180	Slip Ring Alt. Eg 3-a	-
419	PAN1GGA100113	Ccuffia Aspiraz.aria Pred.x Se-m-t100 1cee 1 Schukouffia Predisposta Se-m-t100	-
	PAN3T12VX2	Cover T100 Mf+ Tf Cee	-
447	PAN7MTP060502	Morsettiera Utilizzazione	-

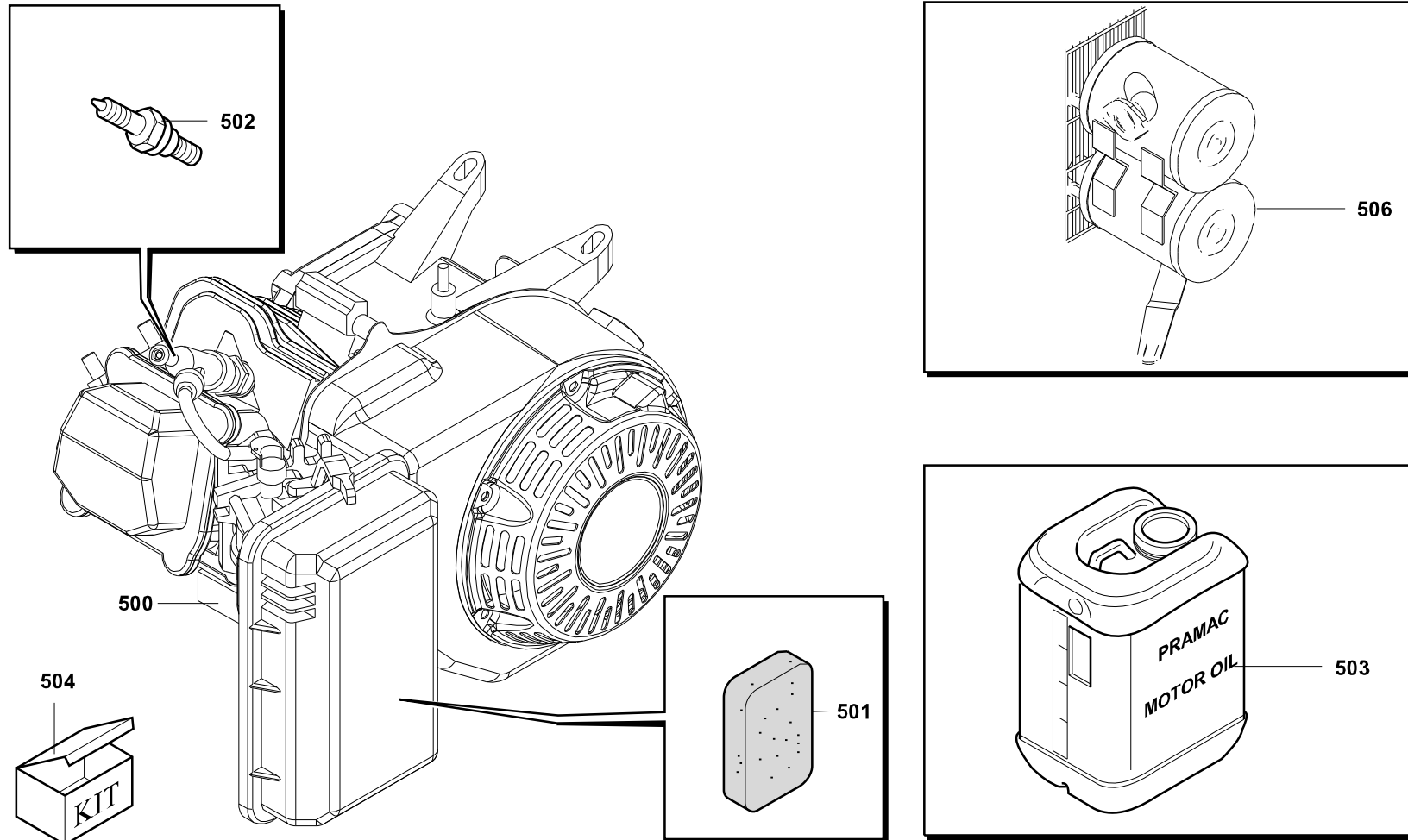



Position	Part Number	Description	Notes
500	EHA130CB21W	Engine Honda Gx390rt2 Vpe9 Air_3000_mech_j609b-_12vdc__ver/sp:	-
501	PEH17211-899-000	Air Filter Element	-
502	PEH98079-56846	Spark Plug Bpr6es	-
503	P3KI00299	Kit Pramac Power	-
504	P3KI00331	Es8000-s8000-sp8000 Maintenance Kit	-
506	SA40016962	Muffler With Protection For S8000 Restyling	-