

Installation, Operation, and Maintenance Manual

8147.020/.190 Bravo 300



Table of Contents

1 Introduction and Safety	3
1.1 Introduction.....	3
1.2 Safety terminology and symbols.....	3
1.3 User safety.....	4
1.4 Ex-approved products.....	4
1.5 Special hazards.....	5
1.6 Protecting the environment.....	6
1.7 Spare parts.....	7
1.8 Warranty.....	7
2 Transportation and Storage	8
2.1 Inspect the delivery.....	8
2.1.1 Inspect the package.....	8
2.1.2 Inspect the unit.....	8
2.2 Transportation guidelines.....	8
2.2.1 Lifting.....	8
2.3 Temperature ranges for transportation, handling and storage.....	9
2.4 Storage guidelines.....	9
3 Product Description	11
3.1 Products included.....	11
3.2 Pump design.....	11
3.3 Monitoring equipment.....	13
3.4 The data plate.....	13
3.5 Approvals.....	15
4 Installation	16
4.1 Install the pump.....	16
4.2 Make the electrical connections.....	17
4.2.1 Prepare the SUBCAB® cables.....	19
4.2.2 Connect the motor cable to the pump.....	20
4.2.3 Connect the motor cable to the starter and monitoring equipment...	21
4.2.4 Cable charts.....	21
4.3 Check the impeller rotation.....	29
5 Operation	31
5.1 Precautions.....	31
5.2 Start the pump.....	31
6 Maintenance	33
6.1 Torque values.....	34
6.2 Change the oil.....	34
6.3 Replace the impeller.....	36
6.3.1 Remove the impeller.....	37
6.3.2 Install the impeller.....	37
6.4 Service the pump.....	38
6.4.1 Inspection.....	38
6.4.2 Major overhaul.....	39
6.4.3 Service in case of alarm.....	39

7 Troubleshooting.....	40
7.1 The pump does not start.....	40
7.2 The pump does not stop when a level sensor is used.....	41
7.3 The pump starts-stops-starts in rapid sequence.....	42
7.4 The pump runs but the motor protection trips.....	42
7.5 The pump delivers too little or no water.....	43
8 Technical Reference.....	44
8.1 Application limits.....	44
8.2 Motor data.....	44

1 Introduction and Safety

1.1 Introduction

Purpose of the manual

The purpose of this manual is to provide necessary information for working with the unit. Read this manual carefully before starting work.

Read and keep the manual

Save this manual for future reference, and keep it readily available at the location of the unit.

Intended use



WARNING:

Operating, installing, or maintaining the unit in any way that is not covered in this manual could cause death, serious personal injury, or damage to the equipment and the surroundings. This includes any modification to the equipment or use of parts not provided by Grindex. If there is a question regarding the intended use of the equipment, please contact a Grindex representative before proceeding.

Other manuals

See also the safety requirements and information in the original manufacturer's manuals for any other equipment furnished separately for use in this system.



1.2 Safety terminology and symbols

About safety messages

It is extremely important that you read, understand, and follow the safety messages and regulations carefully before handling the product. They are published to help prevent these hazards:

- Personal accidents and health problems
- Damage to the product and its surroundings
- Product malfunction



Hazard levels

Hazard level	Indication
 DANGER:	A hazardous situation which, if not avoided, will result in death or serious injury
 WARNING:	A hazardous situation which, if not avoided, could result in death or serious injury
 CAUTION:	A hazardous situation which, if not avoided, could result in minor or moderate injury

Hazard level	Indication
NOTICE:	Notices are used when there is a risk of equipment damage or decreased performance, but not personal injury.

Special symbols

Some hazard categories have specific symbols, as shown in the following table.

Electrical hazard	Magnetic fields hazard
 Electrical Hazard:	 CAUTION:

1.3 User safety

All regulations, codes, and health and safety directives must be observed.

The site

- Observe lockout/tagout procedures before starting work on the product, such as transportation, installation, maintenance, or service.
- Pay attention to the risks presented by gas and vapors in the work area.
- Always be aware of the area surrounding the equipment, and any hazards posed by the site or nearby equipment.

Qualified personnel

This product must be installed, operated, and maintained by qualified personnel only.

Protective equipment and safety devices

- Use personal protective equipment as needed. Examples of personal protective equipment include, but are not limited to, hard hats, safety goggles, protective gloves and shoes, and breathing equipment.
- Make sure that all safety features on the product are functioning and in use at all times when the unit is being operated.

1.4 Ex-approved products

Follow these special handling instructions if you have an Ex-approved unit.

Personnel requirements

These are the personnel requirements for Ex-approved products in potentially explosive atmospheres:

- All work on the product must be carried out by certified electricians and Grindex-authorized mechanics. Special rules apply to installations in explosive atmospheres.
- All users must know about the risks of electric current and the chemical and physical characteristics of the gas, the vapor, or both present in hazardous areas.
- Any maintenance for Ex-approved products must conform to international and national standards (for example, IEC/EN 60079-17).

Grindex disclaims all responsibility for work done by untrained and unauthorized personnel.

Product and product handling requirements

These are the product and product handling requirements for Ex-approved products in potentially explosive atmospheres:

- Only use the product in accordance with the approved motor data.
- You must fully submerge the Ex-approved product during normal operation. Dry running during service and inspection is only permitted outside the classified area.
- Before you start work on the product, make sure that the product and the control panel are isolated from the power supply and the control circuit, so they cannot be energized.
- Do not open the product while it is energized or in an explosive gas atmosphere.
- Make sure that thermal contacts are connected to a protection circuit according to the approval classification of the product, and that they are in use.
- Intrinsically safe circuits are normally required for the automatic level-control system by the level regulator if mounted in zone 0.
- The yield stress of fasteners must be in accordance with the approval drawing and the product specification.
- Do not modify the equipment without approval from an authorized Grindex representative.
- Only use parts that are provided by an authorized Grindex representative.
- The thermal detectors fitted to the stator windings must be connected into the motor control circuit in such a manner as to disconnect the supply to the motor in order to prevent the Temperature Class T3.
- The width of flameproof joints is more than the values specified in the tables of the IEC 60079–1 standard.
- The gap of flameproof joints is less than the values specified in Table 1 of the IEC 60079–1 standard.
- The equipment must be submerged during normal operation.

Guidelines for compliance

Compliance is fulfilled only when you operate the unit within its intended use. Do not change the conditions of the service without the approval of a Grindex representative. When you install or maintain explosion proof products, always comply with the directive and applicable standards (for example, IEC/EN 60079–14).

Minimum permitted liquid level

See the dimensional drawings of the product for the minimum permitted liquid level according to the approval for explosion proof products. If the information is missing on the dimensional drawing, the product must be fully submerged. Level-sensing equipment must be installed if the product can be operated at less than the minimum submersion depth.

Monitoring equipment

For additional safety, use condition-monitoring devices. Examples of condition-monitoring devices include, but are not limited to, the following:

- Level indicators
- Temperature detectors in addition to the stator thermal detectors

Any thermal detectors or thermal protection devices delivered with the pump must be installed and in use at all times.

1.5 Special hazards

Working in temporary installations

Certain industries, such as mining or construction, have a dynamic nature and require temporary installation of equipment. Due to the rugged nature of these applications, normal use of electrical equipment causes wear and tear that can

result in insulation breaks, short-circuits, and exposed wires. To maximize safety when using the unit in rugged applications, the following conditions must be met:

- If electrical cables must be located such that they are at risk of being run over by heavy equipment, then provide mechanical protection to prevent physical damage to the cables.
- Visually inspect electrical equipment before use. Remove from service any equipment with exposed wires or visible damage.
- Use ground-fault circuit interrupters on all receptacles, or have an assured equipment grounding conductor program.

Biological hazards

The product is designed for use in liquids that can be hazardous to your health. Observe these rules when you work with the product:

- Make sure that all personnel who may come into contact with biological hazards are vaccinated against diseases to which they may be exposed.
- Observe strict personal cleanliness.



WARNING: Biological Hazard

Infection risk. Rinse the unit thoroughly with clean water before working on it.

Wash the skin and eyes

Follow these procedures for chemicals or hazardous fluids that have come into contact with your eyes or your skin:

Condition	Action
Chemicals or hazardous fluids in eyes	<ol style="list-style-type: none"> 1. Hold your eyelids apart forcibly with your fingers. 2. Rinse the eyes with eyewash or running water for at least 15 minutes. 3. Seek medical attention.
Chemicals or hazardous fluids on skin	<ol style="list-style-type: none"> 1. Remove contaminated clothing. 2. Wash the skin with soap and water for at least 1 minute. 3. Seek medical attention, if necessary.

1.6 Protecting the environment

Emissions and waste disposal

Observe the local regulations and codes regarding:

- Reporting of emissions to the appropriate authorities
- Sorting, recycling and disposal of solid or liquid waste
- Clean-up of spills

Exceptional sites



CAUTION: Radiation Hazard

Do NOT send the product to Xylem if it has been exposed to nuclear radiation, unless Xylem has been informed and appropriate actions have been agreed upon.

1.7 Spare parts



CAUTION:

Only use the manufacturer's original spare parts to replace any worn or faulty components. The use of unsuitable spare parts may cause malfunctions, damage, and injuries as well as void the warranty.

1.8 Warranty

For information about warranty, see the sales contract.

2 Transportation and Storage

2.1 Inspect the delivery

2.1.1 Inspect the package

1. Inspect the package for damaged or missing items upon delivery.
2. Note any damaged or missing items on the receipt and freight bill.
3. File a claim with the shipping company if anything is out of order.
If the product has been picked up at a distributor, make a claim directly to the distributor.

2.1.2 Inspect the unit

1. Remove packing materials from the product.
Dispose of all packing materials in accordance with local regulations.
2. Inspect the product to determine if any parts have been damaged or are missing.
3. If applicable, unfasten the product by removing any screws, bolts, or straps.
For your personal safety, be careful when you handle nails and straps.
4. Contact the local sales representative if there is any issue.

2.2 Transportation guidelines

Precautions



DANGER: Crush Hazard

Moving parts can entangle or crush. Always disconnect and lock out power before servicing to prevent unexpected startup. Failure to do so could result in death or serious injury.

Position and fastening

The unit can be transported either horizontally or vertically. Make sure that the unit is securely fastened during transportation, and cannot roll or fall over.

2.2.1 Lifting

Always inspect the lifting equipment and tackle before starting any work.



WARNING: Crush Hazard

1) Always lift the unit by its designated lifting points. 2) Use suitable lifting equipment and ensure that the product is properly harnessed. 3) Wear personal protective equipment. 4) Stay clear of cables and suspended loads.

NOTICE:

Never lift the unit by its cables or hose.

Lifting equipment

Lifting equipment is always required when handling the unit. It must fulfill the following requirements:

- The minimum height (contact Grindex for information) between the lifting hook and the floor must be sufficient to lift the unit.
- The lifting equipment must be able to hoist the unit straight up and down, preferably without the need for resetting the lifting hook.

- The lifting equipment must be securely anchored and in good condition.
- The lifting equipment must support weight of the entire assembly and must only be used by authorized personnel.
- Two sets of lifting equipment must be used to lift the unit for repair work.
- The lifting equipment must be dimensioned to lift the unit with any remaining pumped media in it.
- The lifting equipment must not be oversized.



CAUTION: Crush Hazard

Over-dimensioned lifting equipment can lead to injury. A site-specific risk analysis must be done.

2.3 Temperature ranges for transportation, handling and storage

Handling at freezing temperature

At temperatures below freezing, the product and all installation equipment, including the lifting gear, must be handled with extreme care.

Make sure that the product is warmed up to a temperature above the freezing point before starting up. Avoid rotating the impeller/propeller by hand at temperatures below the freezing point. The recommended method to warm the unit up is to submerge it in the liquid which will be pumped or mixed.

NOTICE:

Never use a naked flame to thaw the unit.

Unit in as-delivered condition

If the unit is still in the condition in which it left the factory - all packing materials are undisturbed - then the acceptable temperature range during transportation, handling and storage is: -50°C (-58°F) to $+60^{\circ}\text{C}$ ($+140^{\circ}\text{F}$).

If the unit has been exposed to freezing temperatures, then allow it to reach the ambient temperature of the sump before operating.

Lifting the unit out of liquid

The unit is normally protected from freezing while operating or immersed in liquid, but the impeller/propeller and the shaft seal may freeze if the unit is lifted out of the liquid into a surrounding temperature below freezing.

Units equipped with an internal cooling system are filled with a mixture of water and 30% glycol. This mixture remains a flowing liquid at temperatures down to -13°C (9°F). Below -13°C (9°F), the viscosity increases such that the glycol mixture will lose its flow properties. However, the glycol-water mixture will not solidify completely and thus cannot harm the product.

Follow these guidelines to avoid freezing damage:

1. Empty all pumped liquid, if applicable.
2. Check all liquids used for lubrication or cooling, both oil and water-glycol mixtures, for the presence of unacceptable amounts of water. Change if needed.

2.4 Storage guidelines

Storage location

The product must be stored in a covered and dry location free from heat, dirt, and vibrations.

NOTICE:

Protect the product against humidity, heat sources, and mechanical damage.

NOTICE:

Do not place heavy weights on the packed product.

Long-term storage

If the unit is stored more than six months, then the following apply:

- Before operating the unit after storage, it must be inspected with special attention to the seals and the cable entry.
- The impeller/propeller must be rotated every other month to prevent the seals from sticking together.

3 Product Description

3.1 Products included

Pump model	Standard	EX	Slurry
Bravo 300, 8147.020	X		X
Bravo 300, 8147.190		X	X

3.2 Pump design

The pump is submersible, and driven by an electric motor.

Intended use

The product is intended for moving waste water, sludge, raw and clean water. Always follow the application limits given in *Technical Reference* (page 44). If there is a question regarding the intended use of the equipment, please contact an Grindex representative before proceeding.



DANGER: Explosion/Fire Hazard

Special rules apply to installations in explosive or flammable atmospheres. Do not install the product or any auxiliary equipment in an explosive zone unless it is rated explosion-proof or intrinsically-safe. If the product is EN/ATEX-, MSHA- or FM-approved, then see the specific EX information in the Safety chapter before taking any further actions.

NOTICE:

Do NOT use the unit in highly corrosive liquids.

Spare parts

- Modifications to the unit or installation should only be carried out after consulting with Grindex.
- Original spare parts and accessories authorized by Grindex are essential for compliance. The use of other parts can invalidate any claims for warranty or compensation. For more information contact your Grindex representative.

Pressure class

H High head

Parts

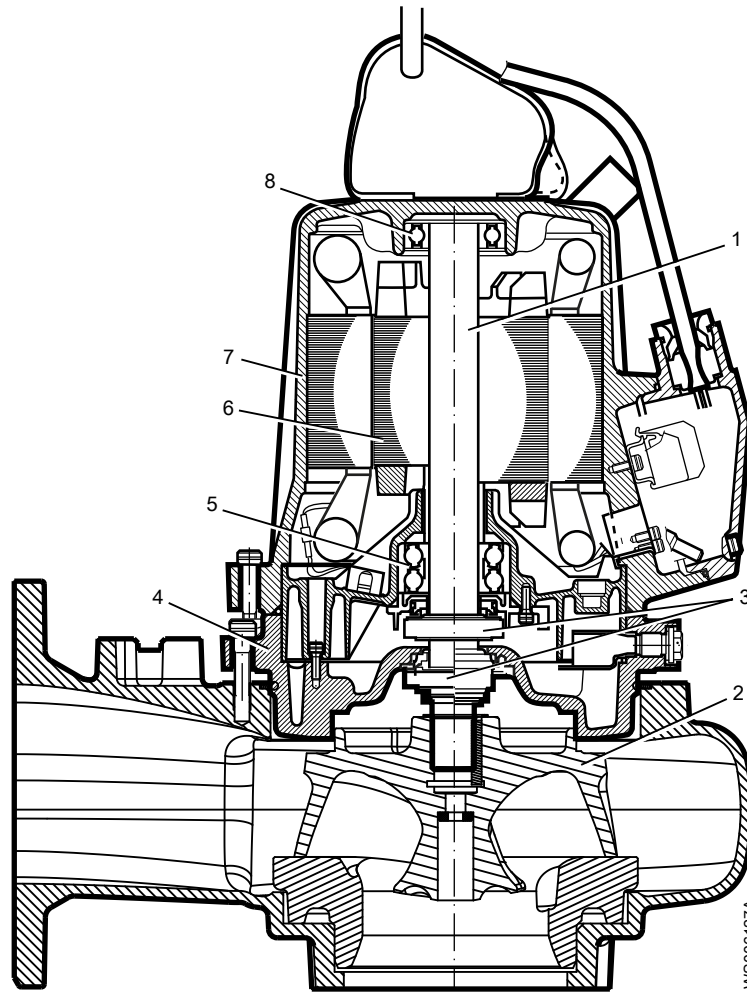

Position	Part	Description
1	Shaft	The shaft is made of stainless steel, with an integrated rotor.
2	Impeller	H-impeller
3	Mechanical seals	One inner and one outer seal in a combination of materials: <ul style="list-style-type: none"> • Aluminium oxide Al_2O_3 • Corrosion-resistant cemented carbide WCCR For information about the pumps mechanical seals, see Parts List.
4	Oil housing	lubricates and cools the seals; the housing acts as a buffer between the pumped liquid and the drive unit.
5	Main bearing	The bearing consisting of a two-row angular contact ball bearing.
6	Motor	For information about the motor, see Technical Reference (page 44).
7	Stator housing	The pump is cooled by the ambient liquid/air.
8	Support bearing	The bearing consisting of a single-row ball bearing.

3.3 Monitoring equipment

The following applies to the monitoring equipment of the pump:

- The stator incorporates three thermal contacts connected in series that activate the alarm and stops the pump at overtemperature
- The thermal contacts open at 125°C (257°F).
- Ex-approved pumps must have thermal contacts connected to the control panel.
- The sensors and optional sensors must be connected to the monitoring equipment.
- The monitoring equipment must be of a design that makes automatic restart impossible.
- Information in the junction box shows if the pump is equipped with optional sensors.

Optional sensors

FLS FLS is a miniature float switch for detection of liquid in the stator housing. Due to its design it is best suited for pumps in a vertical position. The FLS sensor is installed in the bottom of the stator housing.

CLS CLS is a sensor for detection of water in the oil housing. The sensor initiates an alarm when the oil contains approximately 35% water. The sensor is installed in the bearing housing/bearing holder with its sensing part in the oil housing. The CLS sensor is not applicable to Ex-approved pumps.

NOTICE:

The CLS sensor body is made of glass. Handle the sensor with care.

One CLS and one FLS sensor can be used in the same pump, if they are connected in parallel.

3.4 The data plate

Introduction

The data plate is a metal label located on the main body of the pump. The data plate lists key product specifications.

The data plate

This list of callouts is applicable for all versions of data plates:

1. Pump type number
2. Frequency
3. Phases, type of current
4. Rated shaft power
5. Thermal class
6. Locked rotor code-letter
7. Country of origin
8. Maximum power consumption
9. Product weight
10. Maximum submersion depth
11. Degree of protection
12. Maximum capacity
13. Rated current
14. Direction of the start reaction
15. Direction of the impeller rotation
16. Maximum head
17. Serial number

The first two characters describe the production year.

18. Rated voltage

19. Pump model

This is the data plate for non explosion-proof version .020:

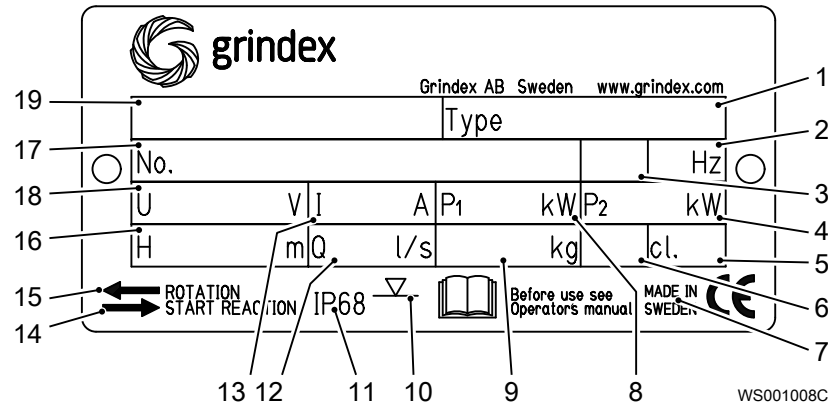

These are the data plates for explosion-proof version .190:

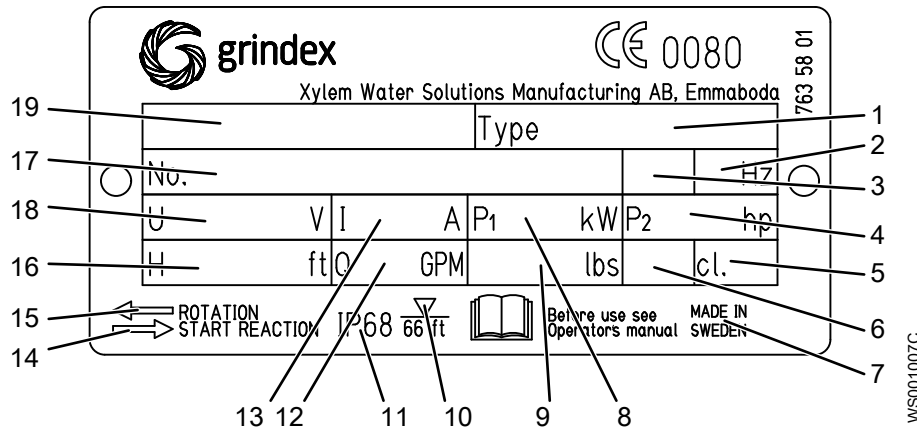
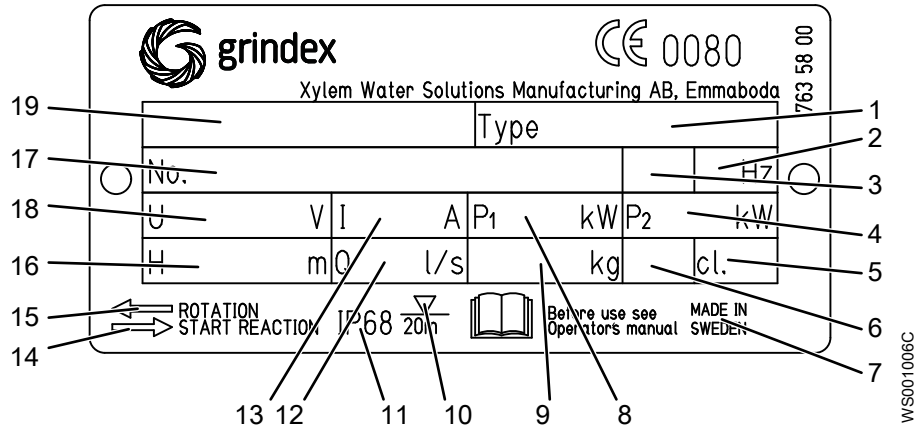

3.5 Approvals

Product approvals for hazardous locations

Pump	Approval
8147.190	<p>European Norm (EN)</p> <ul style="list-style-type: none"> • ATEX Directive • EN 60079-0:2012/A11:2013, EN 60079-1:2007, EN 13463-1:2009, EN 13463-5:2011 • $\text{\textcircled{E}x}$ I M2 c Ex d I Mb • $\text{\textcircled{E}x}$ II 2 G c Ex d IIB T4 Gb <p>FM (FM Approvals)</p> <ul style="list-style-type: none"> • Explosion proof for use in Class I, Div. 1, Group C and D • Dust ignition proof for use in Class II, Div. 1, Group E, F and G • Suitable for use in Class III, Div. 1, Hazardous Locations

EN approval plate

This illustration describes the EN approval plate and the information that is contained in its fields.

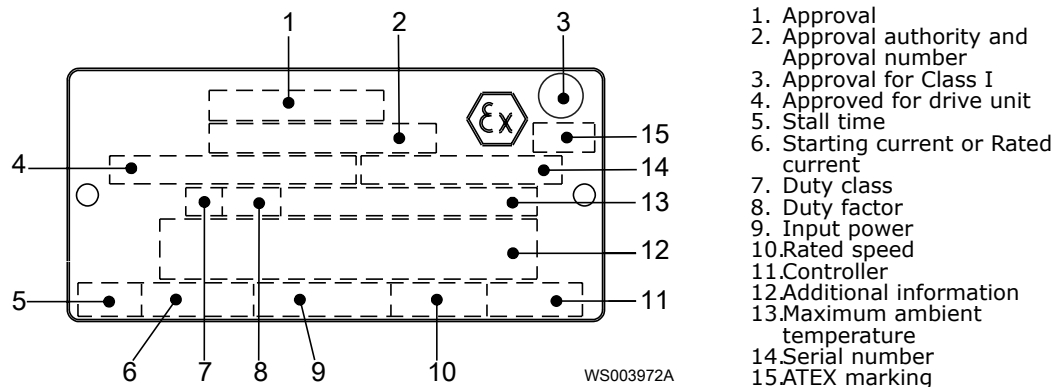

FM approval plate

This illustration describes the FM approval plate and the information that is contained in its fields.

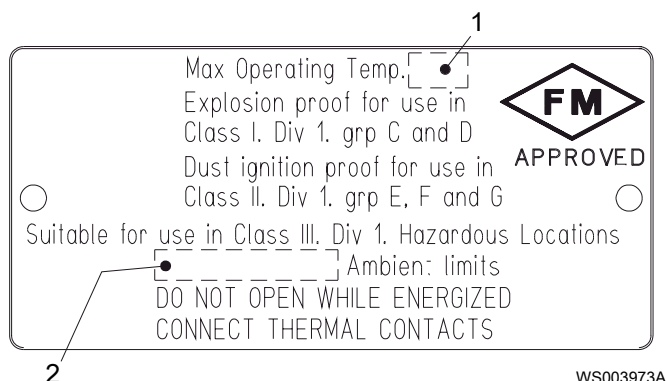

4 Installation

4.1 Install the pump

Before starting work, make sure that the safety instructions in the chapter *Introduction and Safety* (page 3) have been read and understood.



DANGER: Electrical Hazard

Before starting work on the unit, make sure that the unit and the control panel are isolated from the power supply and cannot be energized. This applies to the control circuit as well.



DANGER: Inhalation Hazard

Before entering the work area, make sure that the atmosphere contains sufficient oxygen and no toxic gases.

Hazardous atmospheres



DANGER: Explosion/Fire Hazard

Special rules apply to installations in explosive or flammable atmospheres. Do not install the product or any auxiliary equipment in an explosive zone unless it is rated explosion-proof or intrinsically-safe. If the product is EN/ATEX-, MSHA- or FM-approved, then see the specific EX information in the Safety chapter before taking any further actions.



WARNING: Explosion/Fire Hazard

Do not install CSA-approved products in locations that are classified as hazardous in the National Electric Code(TM), ANSI/NFPA 70-2005.

General requirements

These requirements apply:

- Use the pump dimensional drawing in order to ensure proper installation.

Before installing the pump, do the following:

- Provide a suitable barrier around the work area, for example, a guard rail.
 - Make sure that equipment is in place so that the unit cannot roll or fall over during the installation process.
 - Check the explosion risk before you weld or use electric hand tools.
 - Check that the cable and cable entry have not been damaged during transport.
 - Always remove all debris and waste material from the sump, inlet piping, and discharge connection, before you install the pump.
-

NOTICE:

Do not run the pump dry.

NOTICE:

Never force piping to make a connection with a pump.

Authority regulation

Vent the tank of a sewage station in accordance with local plumbing codes.

Fasteners

- Only use fasteners of the correct size and material.
- Replace all corroded or damaged fasteners.
- Make sure that all the fasteners are correctly tightened and that there are no missing fasteners.

4.2 Make the electrical connections

General precautions



DANGER: Electrical Hazard

Before starting work on the unit, make sure that the unit and the control panel are isolated from the power supply and cannot be energized. This applies to the control circuit as well.

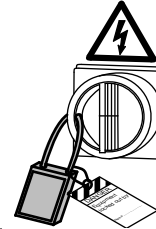

WARNING: Electrical Hazard

Risk of electrical shock or burn. A certified electrician must supervise all electrical work. Comply with all local codes and regulations.



WARNING: Electrical Hazard

There is a risk of electrical shock or explosion if the electrical connections are not correctly carried out, or if there is fault or damage on the product. Visually inspect equipment for damaged cables, cracked casings or other signs of damage. Make sure that electrical connections have been correctly made.



WARNING: Crush Hazard

Risk of automatic restart.



CAUTION: Electrical Hazard

Prevent cables from becoming sharply bent or damaged.

NOTICE:

Leakage into the electrical parts can cause damaged equipment or a blown fuse. Keep the cable ends dry at all times.

Requirements

These general requirements apply for electrical installation:

- The supply authority must be notified before installing the pump if it will be connected to the public mains. When the pump is connected to the public power supply, it may cause flickering of incandescent lamps when started.
- The mains voltage and frequency must agree with the specifications on the data plate. If the pump can be connected to different voltages, then the connected voltage is specified by a yellow sticker close to the cable entry.
- The fuses and circuit breakers must have the proper rating, and the pump overload protection (motor protection breaker) must be connected and set to the rated current according to the data plate and if applicable the cable chart.

The starting current in direct-on-line start can be up to six times higher than the rated current.

- The fuse rating and the cables must be in accordance with the local rules and regulations.
- If intermittent operation is prescribed, then the pump must be provided with monitoring equipment supporting such operation.
- If stated on the data plate, then the motor is convertible between different voltages.
- The thermal contacts/thermistors must be in use.
- For FM-approved pumps, a leakage sensor must be connected and in use in order to meet approval requirements.

Cables

These are the requirements to follow when you install cables:

- The cables must be in good condition, not have any sharp bends, and not be pinched.
- The cables must not be damaged and must not have indentations or be embossed (with markings, etc.) at the cable entry.
- The cable entry seal sleeve and washers must conform to the outside diameter of the cable.
- The minimum bending radius must not be below the accepted value.
- If using a cable which has been used before, a short piece must be peeled off when refitting it so that the cable entry seal sleeve does not close around the cable at the same point again. If the outer sheath of the cable is damaged, then replace the cable. Contact a Grindex service shop.
- The voltage drop in long cables must be taken into account. The drive unit's rated voltage is the voltage measured at the cable connection point in the pump.
- The screened cable must be used according to the European CE and EMC requirements if a Variable Frequency Drive (VFD) is used. For more information, contact your Grindex representative (VFD-supplier).
- For SUBCAB® cables, the twisted pair copper foil must be trimmed.
- All unused conductors must be insulated.

Grounding (earthing)

Grounding (earthing) must be done in compliance with all local codes and regulations.



DANGER: Electrical Hazard

All electrical equipment must be grounded (earthed). Test the ground (earth) lead to verify that it is connected correctly and that the path to ground is continuous.



WARNING: Electrical Hazard

If the power cable is jerked loose, then the ground (earth) conductor must be the last conductor to come loose from its terminal. Make sure that the ground (earth) conductor is longer than the phase conductors at both ends of the cable.



WARNING: Electrical Hazard

Risk of electrical shock or burn. You must connect an additional ground- (earth-) fault protection device to the grounded (earthed) connectors if persons are likely to come into contact with liquids that are also in contact with the pump or pumped liquid.

4.2.1 Prepare the SUBCAB® cables

This section applies to SUBCAB® cables with twisted-pair control cores.

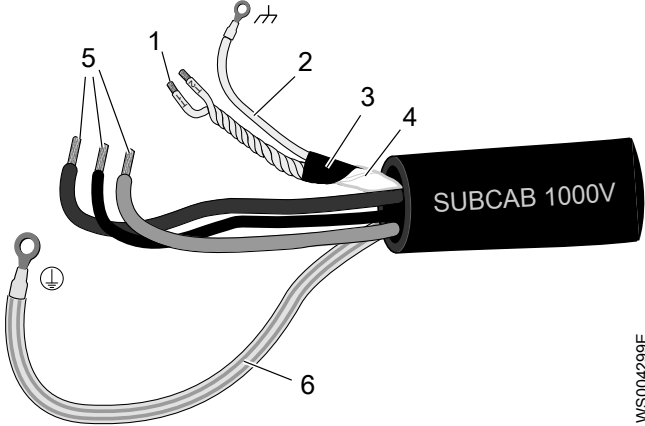
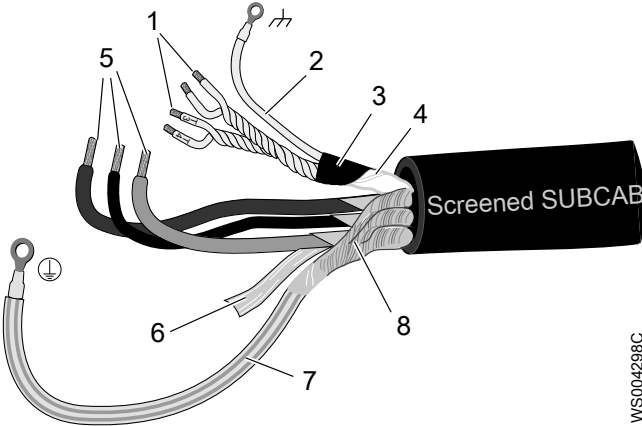
The prepared SUBCAB® cable	The prepared screened SUBCAB® cable
 <ol style="list-style-type: none"> 1. T1+T2 twisted pairs in control element 2. Drain wire in control element (bare copper wire) 3. Screened copper pt-foil 4. Insulation sheath (jacket) or PT-foil for control element 5. Power cores 6. Ground (earth) core <p style="text-align: right; font-size: small;">WS004299E</p>	 <ol style="list-style-type: none"> 1. T1+T2 and T3+T4 twisted pairs in control element 2. Drain wire in control element (bare copper wire) 3. Screened copper pt-foil 4. Insulation sheath (jacket) for control element 5. Power cores 6. Aluminum foil 7. Ground (earth) core with green/yellow shrink hose 8. Uncovered screen/braided wire <p style="text-align: right; font-size: small;">WS004298C</p>

1. Peel off the outer sheath at the end of the cable.
2. Prepare the control element:
 - a) Peel the sheath (if applicable) and the copper foil.

The copper foil is a screen and is conductive. Do not peel more than necessary, and remove the peeled foil.

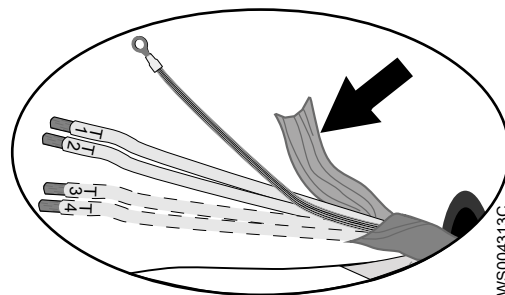

Figure 1: Copper foil on control element.

- b) Put a white shrink hose over the drain wire and the cable terminal.
 - c) Fit a cable lug on the drain wire.
 - d) Twist T1+T2 and T3+T4.
 - e) Put a shrink hose over the control element.

Make sure that the conductive copper foil and drain wire is covered.
3. Prepare the ground (earth) core for SUBCAB™ cable:
 - a) Peel the yellow-green insulation from the ground (earth) core.
 - b) Check that the ground (earth) core is at least 10% longer than the phase cores in the cabinet.
 - c) If applicable, put a cable lug on the ground core.
4. Prepare the ground (earth) core for screened SUBCAB™ cable:
 - a) Untwist the screens around the power cores.
 - b) Put a yellow-green shrink hose over the ground (earth) core.

- Leave a short piece uncovered.
 - c) If applicable, put a cable lug on the screened ground core.
 - d) Twist all power core screens together to create a ground (earth) core and fit a cable terminal to the end.
 - e) Check that the ground (earth) core is at least 10% longer than the phase cores in the cabinet.
5. Connect to ground (earth):
 - Screw: Fit cable terminals to the ground (earth) core and the power cores.
 - Terminal block: Leave the core ends as they are.
 6. Prepare the main leads:
 - a) Remove the aluminum foil around each power core.
 - b) Peel the insulation from each power core.

4.2.2 Connect the motor cable to the pump

NOTICE:

Leakage into the electrical parts can cause damaged equipment or a blown fuse. Keep the end of the motor cable dry at all times.

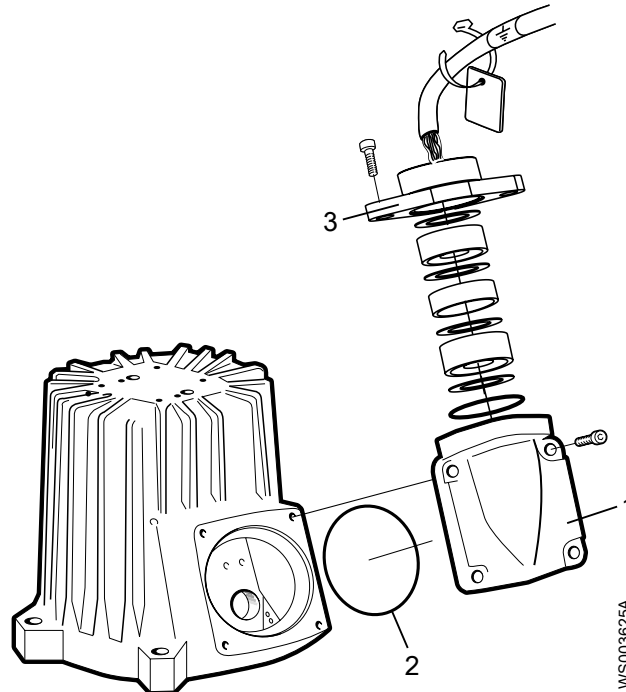

1. Entrance cover
2. O-ring
3. Entrance flange

1. Remove the entrance cover and the O-ring from the stator housing. This provides access to the terminal board/closed end splices.
2. Check the data plate to see which connections are required for the power supply.
3. Arrange the connections on the terminal board/closed end splices in accordance with the required power supply.
4. Connect the mains leads (L1, L2, L3, and ground (earth)) according to applicable cable chart.

The ground (earth) lead must be 50 mm (2.0 in.) longer than the phase leads in the junction box of the unit.
5. Make sure that the pump is correctly connected to ground (earth).

6. Make sure that any thermal contacts incorporated in the pump are properly connected to the terminal block/closed end splices.
7. Install the entrance cover and the O-ring on the stator housing.
8. Fasten the screws on the entrance flange so that the cable insertion assembly bottoms out.

4.2.3 Connect the motor cable to the starter and monitoring equipment



DANGER: Explosion/Fire Hazard

Special rules apply to installations in explosive or flammable atmospheres. Do not install the product or any auxiliary equipment in an explosive zone unless it is rated explosion-proof or intrinsically-safe. If the product is EN/ATEX-, MSHA- or FM-approved, then see the specific EX information in the Safety chapter before taking any further actions.

NOTICE:

- Thermal contacts are incorporated in the pump.
 - Thermal contacts must never be exposed to voltages higher than 250 V, breaking current maximum 4 A. It is recommended that they are connected to 24 V over separate fuses to protect other automatic equipment.
-

1. Connect the T1 and T2 control conductors to the monitoring equipment.
Do not connect the T1 and T2 leads to thermal contacts if the temperature of the pumped liquid is above 40°C (104°F).
-

NOTICE:

Ex-approved products must always have the thermal contacts connected irrespective of the ambient temperature.

2. Connect the mains leads (L1, L2, L3, and earth [ground]) to the starter equipment.
For information about the phase sequence and the color codes of the leads, see [Cable charts](#) (page 21).
3. Check the functionality of the monitoring equipment:
 - a) Check that the signals and the tripping function work properly.
 - b) Check that the relays, lamps, fuses, and connections are intact.
 Replace any defective equipment.

4.2.4 Cable charts

Description

This topic contains general connection information. It also provides cable charts that show connection alternatives for use with different cables and power supply.

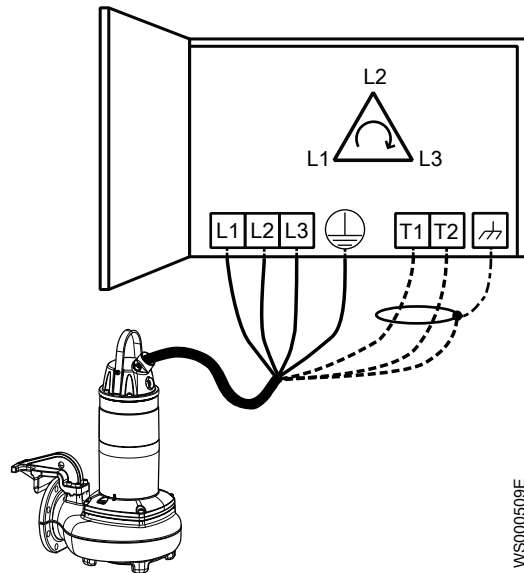

WS000509E

Figure 2: Phase sequence

Connection locations

The figures in this section illustrate how to interpret the connection strip symbols.

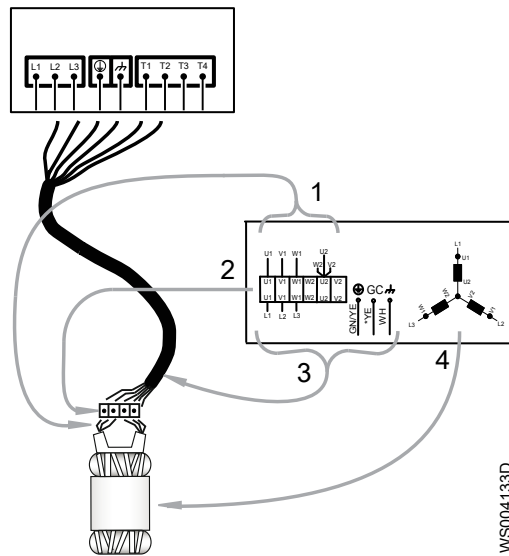

1. Stator leads
2. Terminal board
3. Power cable leads
4. Stator (internal connection illustrated)

WS004133D

3-phase connection

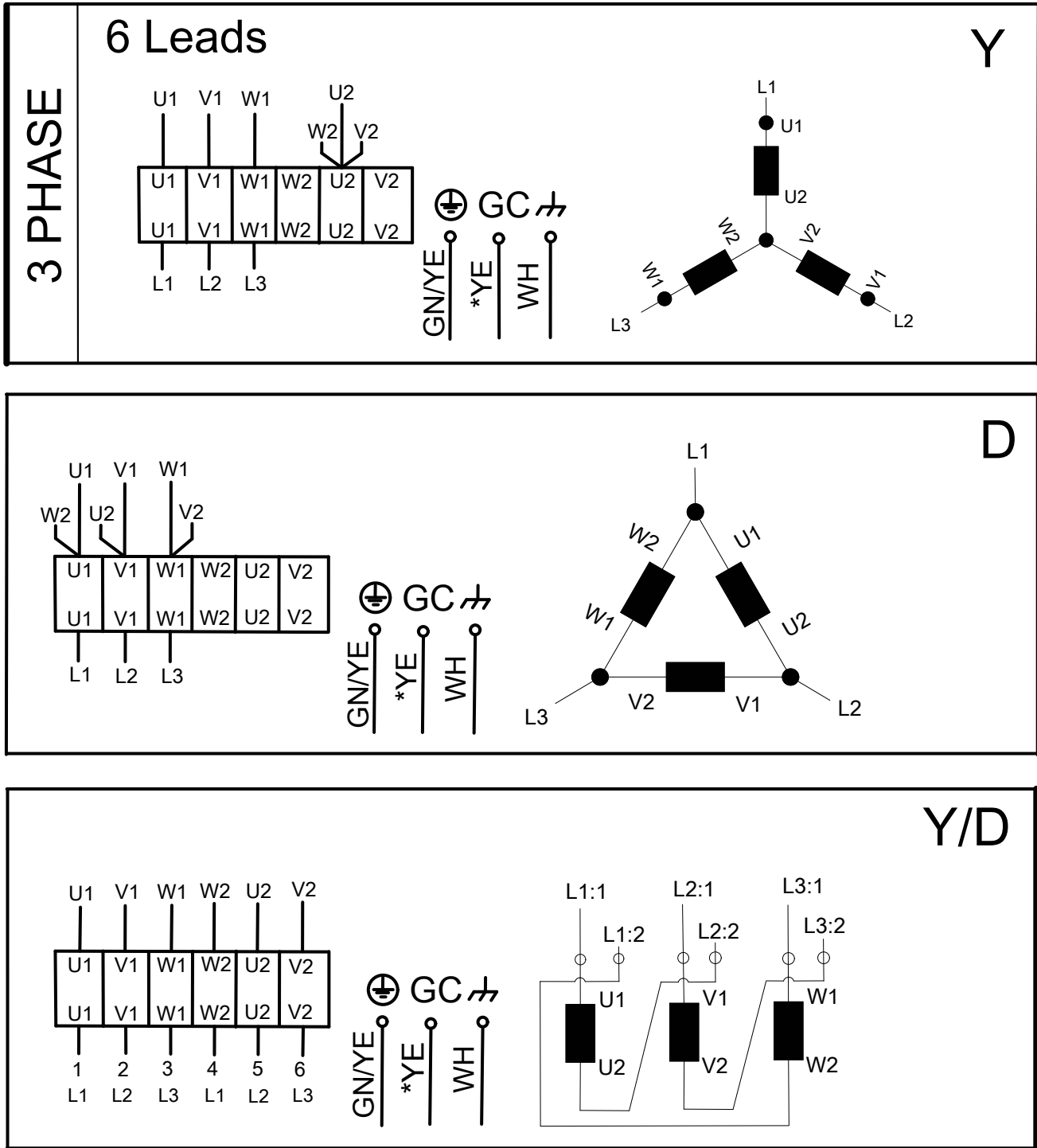

WS004553A

Figure 4: 6 leads

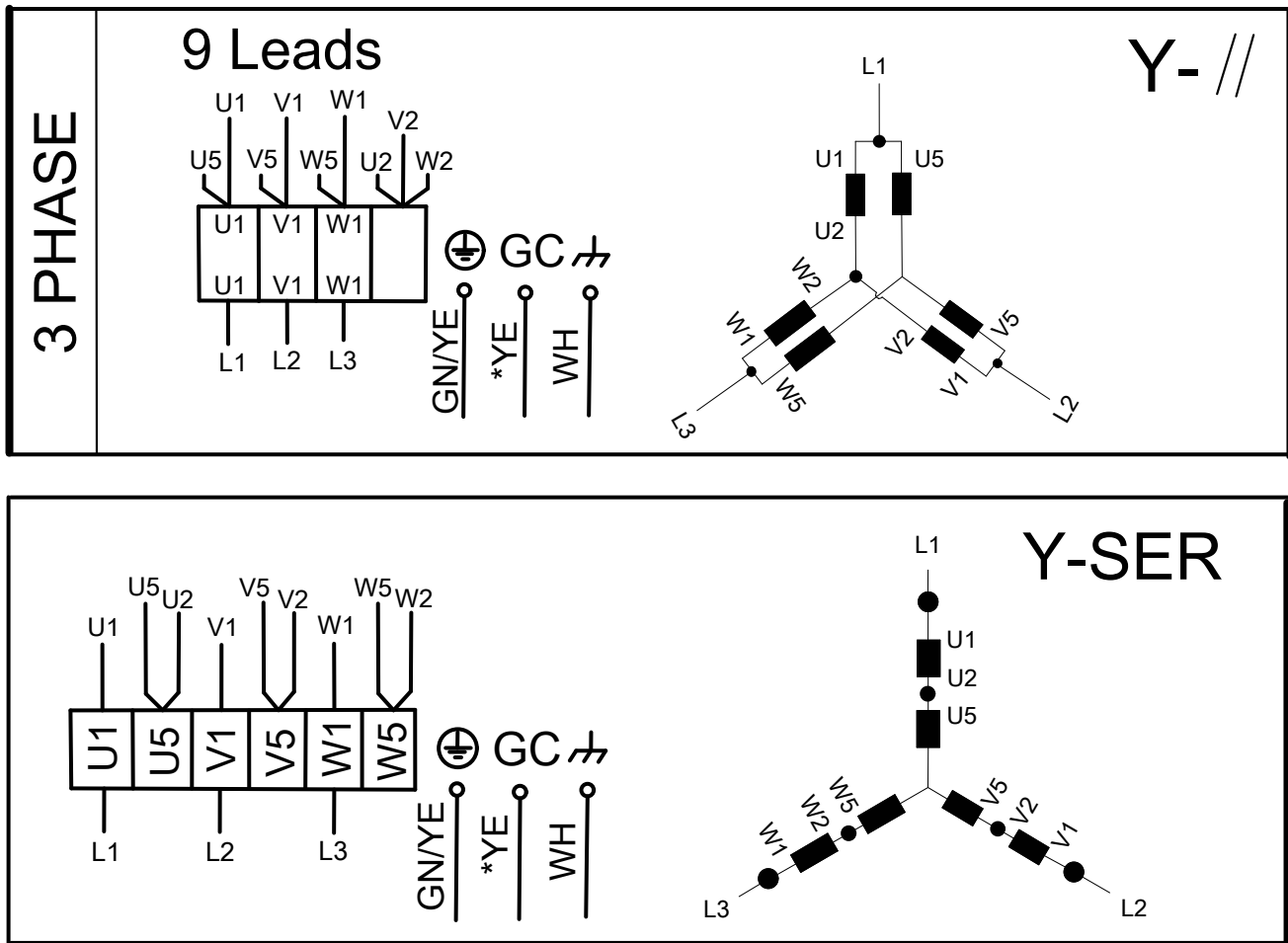

Figure 5: 9 leads

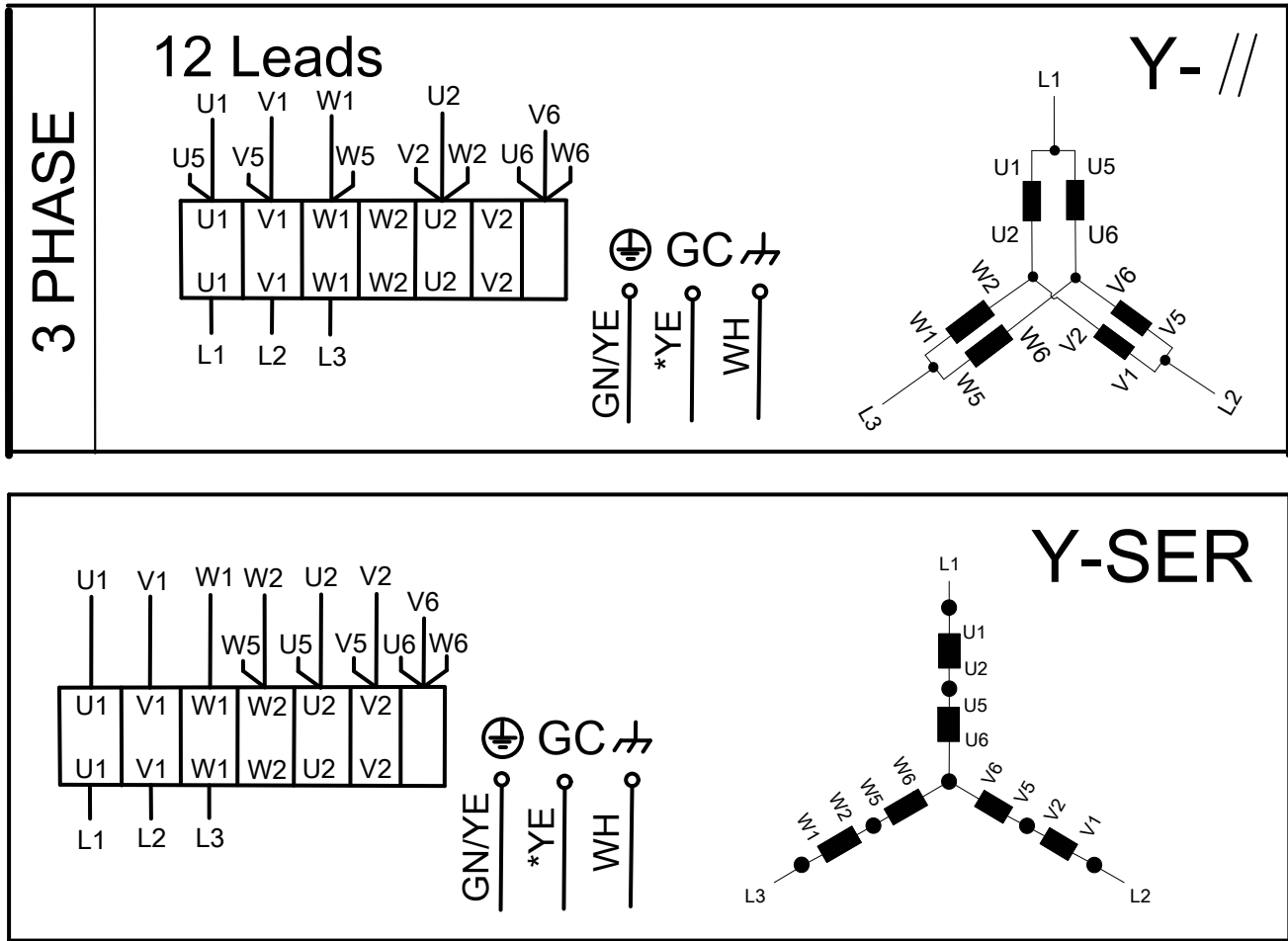

Figure 6: 12 leads

Screened cable connection

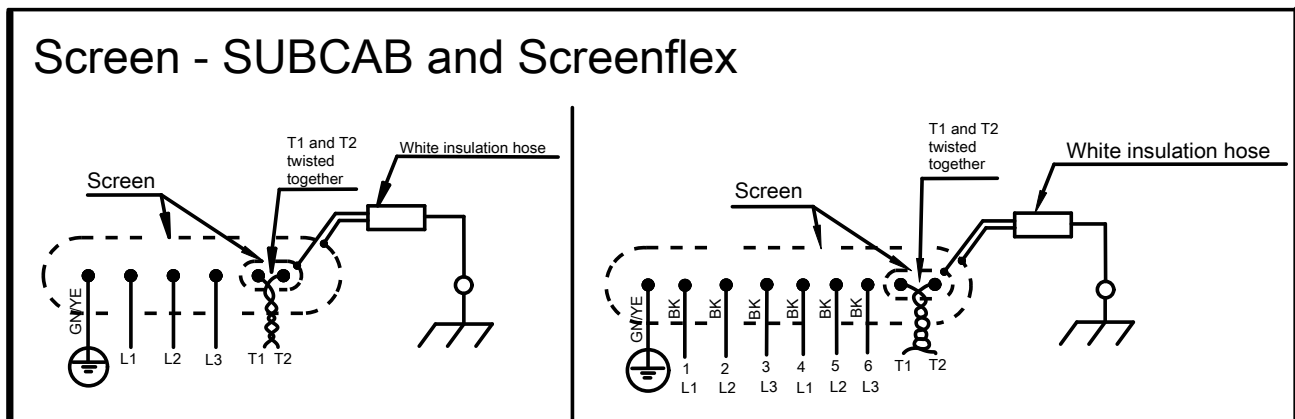
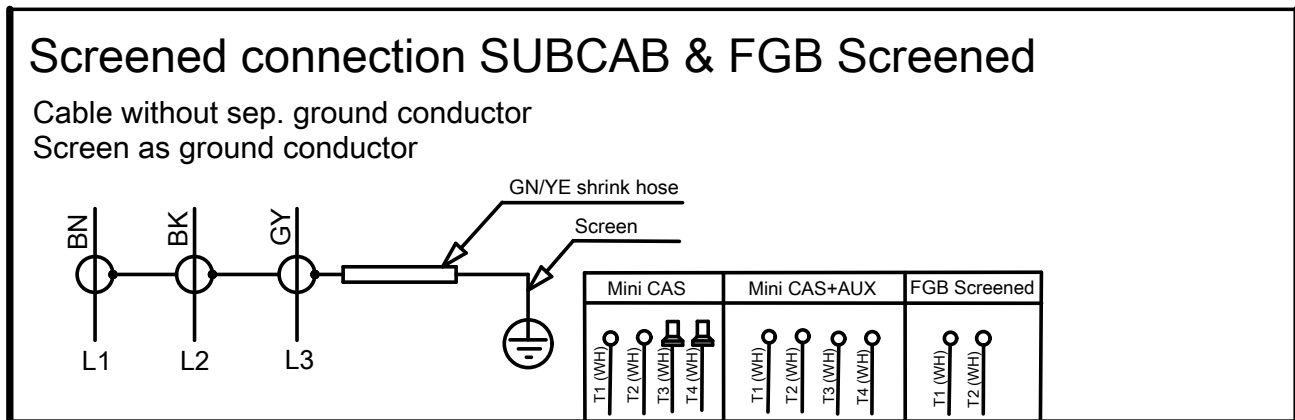
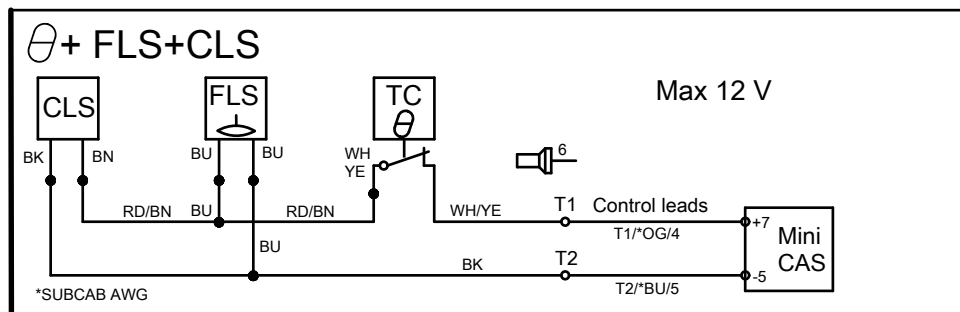
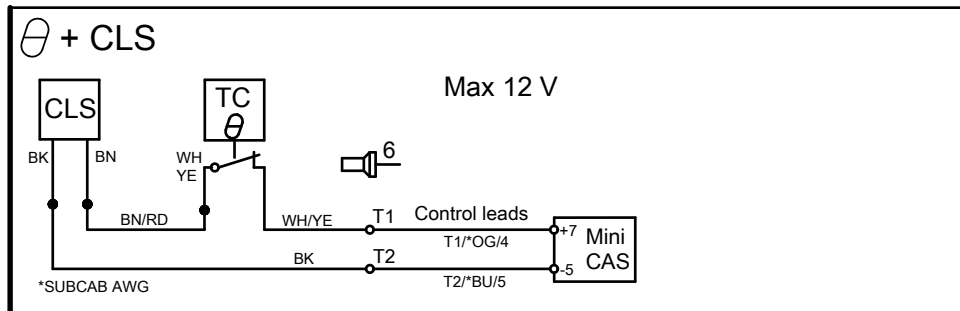
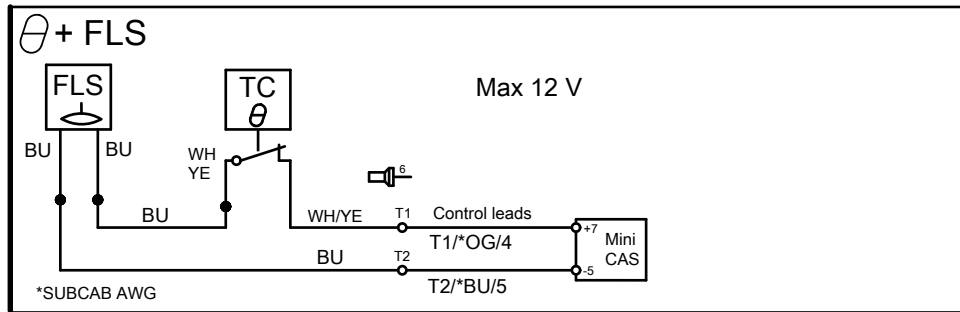
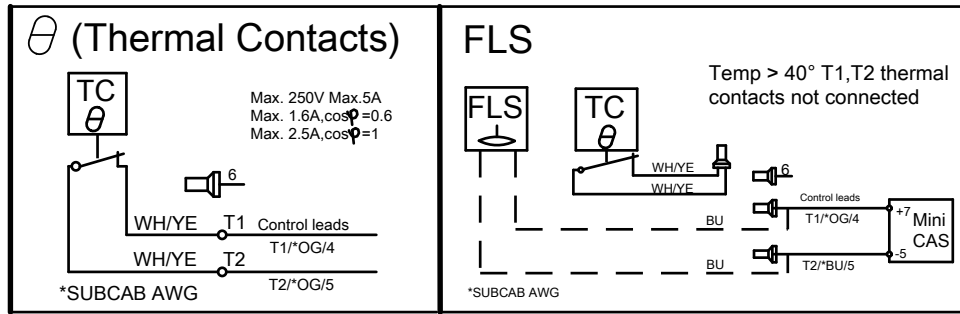

Figure 7: Screened connection SUBCAB and FGB screened, SUBCAB and Screenflex

Sensors connection

SENSORS	Control	SUBCAB 7GX & 4GX Screenflex	SUBCAB AWG	SUBCAB screened
	T1	WH T1	OG	WH T1
	T2	WH T2	BU	WH T2
	T3	-	-	WH T3
	T4	-	-	WH T4



WS004557A

Sensor connection characteristics

The values have a 10 % tolerance.

Sensors	Value (mA)	Definition
FLS and thermal contact	0	Overtemperature
	7.8	OK
	36	Leakage
CLS and thermal contact	0	Overtemperature
	5.5	OK
	29	Leakage (5 seconds delay)
CLS, FLS and thermal contact	0	Overtemperature
	13.3	OK
	36-42	Leakage (0/5 seconds delay)

4.3 Check the impeller rotation



CAUTION: Crush Hazard

The starting jerk can be powerful. Make sure nobody is close to the unit when it is started.

1. Start the motor.
2. Stop the motor after a few seconds.
3. Check that the impeller rotates according to this illustration.

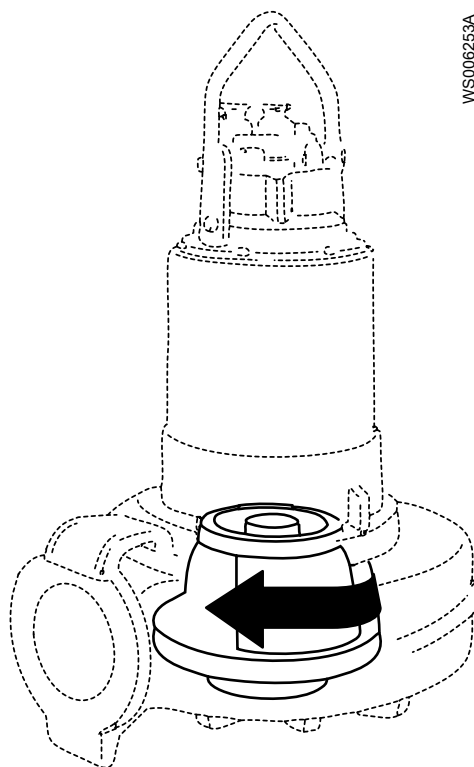

The correct direction of impeller rotation is clockwise when you look at the pump from above.

4. If the impeller rotates in the wrong direction, then do one of these steps:
 - If the motor has a 1-phase connection, then contact the local Grindex shop.
 - If the motor has a 3-phase connection, then transpose two phase leads and do this procedure again.

5 Operation

5.1 Precautions

Before taking the unit into operation, check the following:

- All recommended safety devices are installed.
- The cable and cable entry have not been damaged.
- All debris and waste material has been removed.

NOTICE:

Never operate the pump with the discharge line blocked, or the discharge valve closed.



WARNING: Crush Hazard

Risk of automatic restart.

Distance to wet areas



WARNING: Electrical Hazard

Risk of electrical shock or burn. You must connect an additional ground- (earth-) fault protection device to the grounded (earthed) connectors if persons are likely to come into contact with liquids that are also in contact with the pump or pumped liquid.



CAUTION: Electrical Hazard

Risk of electrical shock or burn. The equipment manufacturer has not evaluated this unit for use in swimming pools. If used in connection with swimming pools then special safety regulations apply.

Noise level

NOTICE:

The sound power level of the product is lower than 70 dB(A). However, in some installations the resulting sound pressure level may exceed 70 dB(A) at certain operating points on the performance curve. Make sure that you understand the noise level requirements in the environment where the product is installed. Failure to do so may result in hearing loss or violation of local laws.

5.2 Start the pump



CAUTION: Crush Hazard

The starting jerk can be powerful. Make sure nobody is close to the unit when it is started.

NOTICE:

Make sure that the rotation of the impeller is correct. For more information, see Check the impeller rotation.

1. Check the oil level in the oil housing.
2. Remove the fuses or open the circuit breaker, and check that the impeller can rotate freely.



WARNING: Crush Hazard

Never put your hand into the pump housing.

3. Conduct insulation test phase to ground. To pass, the value must exceed 5 megaohms.
4. Check that the monitoring equipment works.
5. Start the pump.

6 Maintenance

Precautions

Before starting work, make sure that the safety instructions in the chapter *Introduction and Safety* (page 3) have been read and understood.



DANGER: Crush Hazard

Moving parts can entangle or crush. Always disconnect and lock out power before servicing to prevent unexpected startup. Failure to do so could result in death or serious injury.

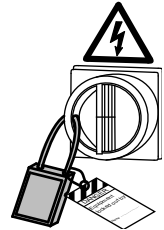

WARNING: Biological Hazard

Infection risk. Rinse the unit thoroughly with clean water before working on it.



CAUTION: Crush Hazard

Make sure that the unit cannot roll or fall over and injure people or damage property.

Make sure that you follow these requirements:

- Check the explosion risk before you weld or use electrical hand tools.
- Allow all system and pump components to cool before you handle them.
- Make sure that the product and its components have been thoroughly cleaned.
- Make sure that the work area is well-ventilated before you open any vent or drain valves, remove any plugs, or disassemble the unit.
- Do not open any vent or drain valves or remove any plugs while the system is pressurized. Make sure that the pump is isolated from the system and that pressure is relieved before you disassemble the pump, remove plugs, or disconnect piping.

Ground continuity verification

A ground (earth) continuity test must always be performed after service.

Maintenance guidelines

During the maintenance and before reassembly, always remember to perform these tasks:

- Clean all parts thoroughly, particularly O-ring grooves.
- Change all O-rings, gaskets, and seal washers.
- Lubricate all springs, screws, O-rings with grease.

During the reassembly, always make sure that existing index markings are in line.

The reassembled drive unit must always be insulation-tested and the reassembled pump must always be test-run before normal operation.

6.1 Torque values

All screws and nuts must be lubricated to achieve correct tightening torque. Screws that are screwed into stainless steel must have the threads coated with suitable lubricants to prevent seizing.

If there is a question regarding the tightening torques, please contact the local sales and service representative.

Screws and nuts

Table 1: Stainless steel, A2 and A4, torque Nm (ft-lbs)

Property class	M4	M5	M6	M8	M10	M12	M16	M20	M24	M30
50	1.0 (0.74)	2.0 (1.5)	3.0 (2.2)	8.0 (5.9)	15 (11)	27 (20)	65 (48)	127 (93.7)	220 (162)	434 (320)
70, 80	2.7 (2)	5.4 (4)	9.0 (6.6)	22 (16)	44 (32)	76 (56)	187 (138)	364 (268)	629 (464)	1240 (915)
100	4.1 (3)	8.1 (6)	14 (10)	34 (25)	66 (49)	115 (84.8)	248 (183)	481 (355)	—	—

Table 2: Steel, torque Nm (ft-lbs)

Property class	M4	M5	M6	M8	M10	M12	M16	M20	M24	M30
8.8	2.9 (2.1)	5.7 (4.2)	9.8 (7.2)	24 (18)	47 (35)	81(60)	194 (143)	385 (285)	665 (490)	1310 (966.2)
10.9	4.0 (2.9)	8.1 (6)	14 (10)	33 (24)	65 (48)	114 (84)	277 (204)	541 (399)	935 (689)	1840 (1357)
12.9	4.9 (3.6)	9.7 (7.2)	17 (13)	40 (30)	79 (58)	136 (100)	333 (245)	649 (480)	1120 (825.1)	2210 (1630)

Hexagon screws with countersunk heads

For hexagon socket head screws with countersunk head, maximum torque for all property classes must be 80% of the values for property class 8.8 above.

6.2 Change the oil

This image shows the plugs that are used to change the oil.

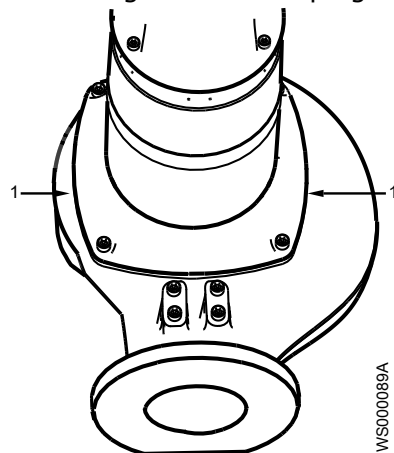

1. Oil plug

Empty the oil



CAUTION: Compressed Gas Hazard

Air inside the chamber may cause parts or liquid to be propelled with force. Be careful when opening. Hold a rag over the plug to prevent liquid from spraying out.

1. Place the pump in a horizontal position and unscrew the oil plug.
If the pump has a hole with the markings "oil out" it is important that this hole is used for drainage.

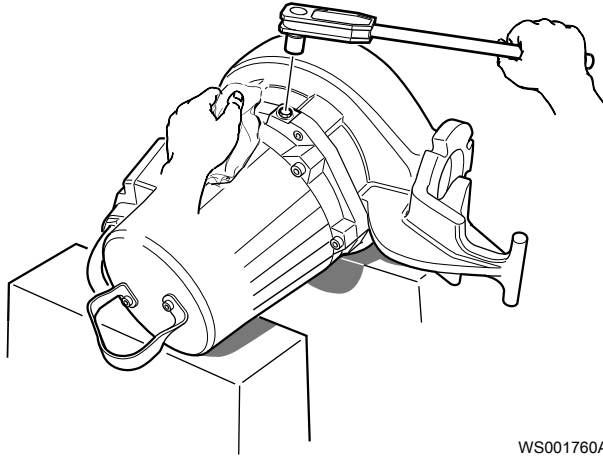

WS001760A

2. Place a container under the pump and turn the pump.
3. Unscrew the other oil plug.
If this hole has the markings "oil in", raise the pump upright for a short period of time during drainage in order to drain all the oil.

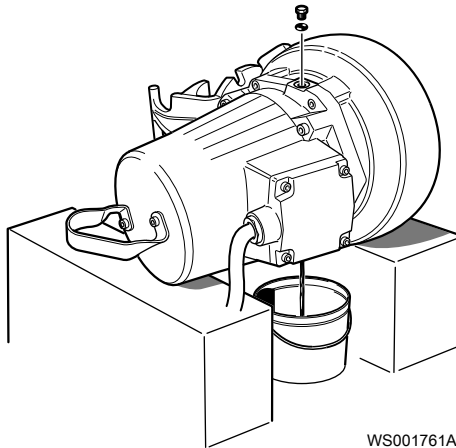

WS001761A

Fill with oil

The oil should be a medical white oil of paraffin type that fulfills FDA 172.878 (a) and viscosity close to VG32. Examples of suitable oil types are the following:

- Statoil MedicWay 32™
- BP Enerpar M 004™
- Shell Ondina 927™
- Shell Ondina X430™

1. Replace the O-rings of the oil plugs.
2. Refit an oil plug in the hole that faces downwards or is marked "oil out", and tighten.

Tightening torque: 10-40 Nm (7.5-29.5 ft-lb)

3. Fill with oil through the hole on the opposite side or the hole marked "oil in".
If the hole is marked "oil in", slightly tilt the pump and lower it again in order to fill the pump with the correct quantity.
Quantity: approximately 2.1 L (2.2 qt).

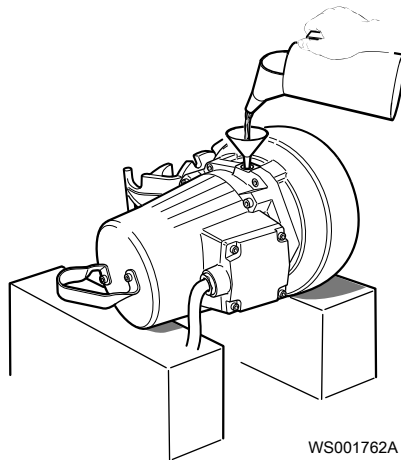

4. Refit the oil plug and tighten.
Tightening torque: 10-40 Nm (7.5-29.5 ft-lb).

6.3 Replace the impeller

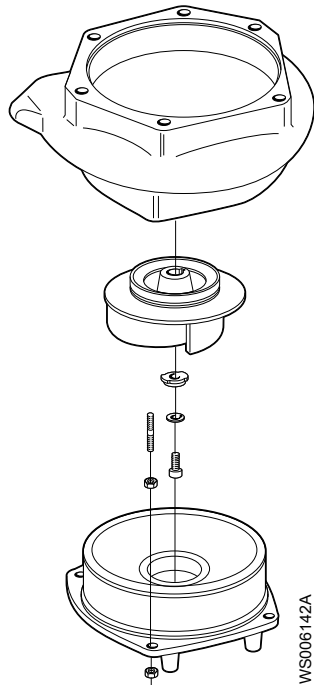

Required tools:

- 10 mm hexagon bit adapter with an extension of at least 125 mm (4.92 in.)
- Impeller puller
If applicable, contact your local Grindex representative for correct type and size.
- Rod (wooden or copper) for locking the impeller in place, if applicable.
- Two crowbars, if applicable

**WARNING:**

- If you fail with the impeller installation, you must redo the installation procedure from the beginning.
- When laying the pump on its side, do not allow the weight of the pump to rest on any portion of the impeller. The impeller must not be allowed to make contact with the concrete floor or other hard and rough surfaces.

**CAUTION: Cutting Hazard**

Worn parts can have sharp edges. Wear protective clothing.

6.3.1 Remove the impeller

**CAUTION: Cutting Hazard**

Worn parts can have sharp edges. Wear protective clothing.

1. Remove the suction cover.
If necessary, then pry off the suction cover.
2. Remove the impeller screw and the washer.
If applicable, use the rod.
3. Remove the impeller from the shaft:
 - a) Insert a M16 screw into the square nut.
 - b) Turn the screw to push off the impeller.
4. Remove the screw and the square nut.

6.3.2 Install the impeller

1. Prepare the shaft:
 - a) Make sure that the end of the shaft is clean and free from burrs.
Polish off any flaws with a fine emery cloth.
 - b) Make sure that the parallel key is seated in the keyway on the shaft.
2. Mount the impeller:
 - a) Fit the washer and square nut to the lubricated impeller screw.
 - b) Press the impeller onto the shaft with the impeller screw.
3. Tighten the impeller screw.
Tightening torque: 80 Nm (59 ft-lbs)
If applicable, use the rod.
Check that the impeller can rotate freely.
4. Mount the suction cover:
 - a) Fit the studs on the pump housing.
 - b) Fit the first hexagon nut onto the studs.
 - c) Fit the suction cover to the studs.
Make sure that the impeller rotates freely from the suction cover before tightening the hexagon nuts. The clearance between the impeller and the suction cover should be as small as possible.
 - d) Fit the second hexagon nuts onto the studs.
 - e) Tighten the nuts.
Tightening torque: 57 Nm (42 ft-lb).
5. Raise the pump to a vertical position.

Check that the impeller can rotate freely.

6.4 Service the pump

Type of service	Purpose	Inspection interval
Initial inspection	To make a check up of the pump condition by an authorized Grindex service representative and, based on the result and findings from these measures, to determine the intervals for periodical inspection and major overhaul for the specific installation.	Within the first year of operation.
Periodical inspection	To prevent operational interruptions and machine breakdown. Measures to secure performance and pump efficiency are defined and decided for each individual application. It can include such things as impeller trimming, wear part control and replacement, control of zinc-anodes and control of the stator.	Up to every year Applies to normal applications and operating conditions at media (liquid) temperatures <40°C.
Major overhaul	To secure a long operating lifetime for the product. It includes replacement of key components and the measures taken during an inspection.	Up to every 3 year These intervals apply to normal applications and operating conditions at media (liquid) temperatures <40°C.

NOTICE:

Shorter intervals may be required when the operating conditions are extreme, for example with very abrasive or corrosive applications or when the liquid temperatures exceed 40°C (104°F).

6.4.1 Inspection

Service item	Action
Cable	<ol style="list-style-type: none"> 1. If the outer jacket is damaged, replace the cable. 2. Check that the cables do not have any sharp bends and are not pinched.
Connection to power	Check that the connections are properly secured.
Electrical cabinets	Check that they are clean and dry.
Impeller	<ol style="list-style-type: none"> 1. Check the impeller clearance. 2. Adjust the impeller, if necessary.
Stator housing	<ol style="list-style-type: none"> 1. Drain all liquid, if any. 2. Check the resistance of the leakage sensor. Normal value approximately 1500 ohms, alarm approximately 430 ohms.
Insulation	<p>Use a megger maximum 1000 V.</p> <ol style="list-style-type: none"> 1. Check that the resistance between the ground (earth) and phase lead is more than 5 megohms. 2. Conduct a phase-to-phase resistance check.

Service item	Action
Junction box	Check that it is clean and dry.
Lifting device	Check that the local safety regulations are followed.
Lifting handle	<ol style="list-style-type: none"> 1. Check the screws. 2. Check the condition of the lifting handle and the chain. 3. If necessary, replace.
O-rings	<ol style="list-style-type: none"> 1. Replace the oil plug O-rings. 2. Replace the O-rings at the entrance or junction cover. 3. Grease the new O-rings.
Overload protection and other protections	Check the correct settings.
Personnel safety devices	Check the guard rails, covers, and other protections.
Rotation direction	Check the impeller rotation.
Oil housing	Fill with new oil, if necessary.
Terminal block/closed end splice	Check that the connections are properly secured.
Thermal contacts	Normally closed circuit; interval 0–1 ohm.
Voltage and amperage	Check the running values.

6.4.2 Major overhaul

The basic repair kit includes O-rings, seals, and bearings.

For a major overhaul, do the following in addition to the tasks listed under Inspection.

Service item	Action
Support and main bearing	Replace the bearings with new bearings.
Mechanical seal	Replace with new seal units.

6.4.3 Service in case of alarm

For information about indication values for sensors, see [Sensors connection](#) (page 28).

Alarm source	Action
CLS	Check for water in the oil housing. If the oil contains too much water, then do the following: <ol style="list-style-type: none"> 1. Drain the oil and water. 2. Replace with new oil.
FLS	<ol style="list-style-type: none"> 1. Check for liquid in the stator housing. 2. Drain all liquid, if any. 3. Check the mechanical seal unit, the O-rings, and the cable entry, if liquid was found.
Thermal contact	Check the start and stop levels.
The overload protection	Check that the impeller can rotate freely.

7 Troubleshooting

Introduction



DANGER: Electrical Hazard

Troubleshooting a live control panel exposes personnel to hazardous voltages. Electrical troubleshooting must be done by a qualified electrician.

Follow these guidelines when troubleshooting:

- Disconnect and lock out the power supply except when conducting checks that require voltage.
- Make sure that no one is near the unit when the power supply is reconnected.
- When troubleshooting electrical equipment, use the following:
 - Universal instrument multimeter
 - Test lamp (continuity tester)
 - Wiring diagram

7.1 The pump does not start



DANGER: Crush Hazard

Moving parts can entangle or crush. Always disconnect and lock out power before servicing to prevent unexpected startup. Failure to do so could result in death or serious injury.

NOTICE:

Do NOT override the motor protection repeatedly if it has tripped. Doing so may result in equipment damage.

Cause	Remedy
An alarm signal has been triggered on the control panel.	Check that: <ul style="list-style-type: none"> • The impeller rotates freely. • The sensor indicators do not indicate an alarm. • The overload protection is not tripped. If the problem still persists: Contact the local Grindex service shop.
The pump does not start automatically, but can be started manually.	Check that: <ul style="list-style-type: none"> • The start level regulator is functioning. Clean or replace if necessary. • All connections are intact. • The relay and contactor coils are intact. • The control switch (Man/Auto) makes contact in both positions. Check the control circuit and functions.

Cause	Remedy
The installation is not receiving voltage.	Check that: <ul style="list-style-type: none"> • The main power switch is on. • There is control voltage to the start equipment. • The fuses are intact. • There is voltage in all phases of the supply line. • All fuses have power and that they are securely fastened to the fuse holders. • The overload protection is not tripped. • The motor cable is not damaged.
The impeller is stuck.	Clean: <ul style="list-style-type: none"> • The impeller • The sump in order to prevent the impeller from clogging again.

If the problem persists, contact the local Grindex service shop. Always state the product number and the serial number of your pump when you contact Grindex, see [Product Description](#) (page 11).

7.2 The pump does not stop when a level sensor is used



DANGER: Crush Hazard

Moving parts can entangle or crush. Always disconnect and lock out power before servicing to prevent unexpected startup. Failure to do so could result in death or serious injury.

Cause	Remedy
The pump is unable to empty the sump to the stop level.	Check that: <ul style="list-style-type: none"> • There are no leaks from the piping and/or discharge connection. • The impeller is not clogged. • The non-return valve(s) are functioning properly. • The pump has adequate capacity. For information: Contact the local Grindex service shop.
There is a malfunction in the level-sensing equipment.	<ul style="list-style-type: none"> • Clean the level regulators. • Check the functioning of the level regulators. • Check the contactor and the control circuit. • Replace all defective items.
The stop level is set too low.	Raise the stop level.

If the problem persists, contact the local Grindex service shop. Always state the product number and the serial number of your pump when you contact Grindex, see [Product Description](#) (page 11).

7.3 The pump starts-stops-starts in rapid sequence

Cause	Remedy
The pump starts due to back-flow which fills the sump to the start level again.	Check that: <ul style="list-style-type: none"> The distance between the start and stop levels is sufficient. The non-return valve(s) work(s) properly. The length of the discharge pipe between the pump and the first non-return valve is sufficiently short.
The self-holding function of the contactor malfunctions.	Check: <ul style="list-style-type: none"> The contactor connections. The voltage in the control circuit in relation to the rated voltages on the coil. The functioning of the stop-level regulator. Whether the voltage drop in the line at the starting surge causes the contactor's self-holding malfunction.

If the problem persists, contact the local Grindex service shop. Always state the product number and the serial number of your pump when you contact Grindex, see [Product Description](#) (page 11).

7.4 The pump runs but the motor protection trips



DANGER: Crush Hazard

Moving parts can entangle or crush. Always disconnect and lock out power before servicing to prevent unexpected startup. Failure to do so could result in death or serious injury.

NOTICE:

Do NOT override the motor protection repeatedly if it has tripped. Doing so may result in equipment damage.

Cause	Remedy
The motor protection is set too low.	Set the motor protection according to the data plate and if applicable the cable chart.
The impeller is difficult to rotate by hand.	<ul style="list-style-type: none"> Clean the impeller. Clean out the sump. Check that the impeller is properly trimmed.
The drive unit is not receiving full voltage on all three phases.	<ul style="list-style-type: none"> Check the fuses. Replace fuses that have tripped. If the fuses are intact, then notify a certified electrician.
The phase currents vary, or they are too high.	Contact the local Grindex service shop.
The insulation between the phases and ground in the stator is defective.	<ol style="list-style-type: none"> Use an insulation tester. With a 1000 V DC megger, check that the insulation between the phases and between any phase and ground is > 5 megaohms. If the insulation is less, then do the following: Contact the local Grindex service shop.

Cause	Remedy
The density of the pumped fluid is too high.	Make sure that the maximum density is 1100 kg/m ³ (9.2 lb/US gal) <ul style="list-style-type: none"> • Change to a more suitable pump • Contact the local Grindex service shop.
There is a malfunction in the overload protection.	Replace the overload protection.

If the problem persists, contact the local Grindex service shop. Always state the product number and the serial number of your pump when you contact Grindex, see [Product Description](#) (page 11).

7.5 The pump delivers too little or no water



DANGER: Crush Hazard

Moving parts can entangle or crush. Always disconnect and lock out power before servicing to prevent unexpected startup. Failure to do so could result in death or serious injury.

NOTICE:

Do NOT override the motor protection repeatedly if it has tripped. Doing so may result in equipment damage.

Cause	Remedy
The impeller rotates in the wrong direction.	<ul style="list-style-type: none"> • If it is a 3-phase pump, then transpose two phase leads. • If it is a 1-phase pump, then do the following: Contact the local Grindex service shop.
One or more of the valves are set in the wrong positions.	<ul style="list-style-type: none"> • Reset the valves that are set in the wrong position. • Replace the valves, if necessary. • Check that all valves are correctly installed according to media flow. • Check that all valves open correctly.
The impeller is difficult to rotate by hand.	<ul style="list-style-type: none"> • Clean the impeller. • Clean out the sump. • Check that the impeller is properly trimmed.
The pipes are obstructed.	To ensure a free flow, clean out the pipes.
The pipes and joints leak.	Find the leaks and seal them.
There are signs of wear on the impeller, pump, and casing.	Replace the worn parts.
The liquid level is too low.	<ul style="list-style-type: none"> • Check that the level sensor is set correctly. • Depending on the installation type, add a means for priming the pump, such as a foot valve.

If the problem persists, contact the local Grindex service shop. Always state the product number and the serial number of your pump when you contact Grindex, see [Product Description](#) (page 11).

8 Technical Reference

8.1 Application limits

Data	Description
Liquid temperature	40°C (104°F) maximum
pH of the pumped media (liquid)	5.5–14
Liquid density	1100 kg/m ³ (9.2 lb per US gal) maximum
Depth of immersion	Maximum 20 m (65 ft)
Other	For the specific weight, current, voltage, power ratings, and speed of the pump, see the data plate of the pump.

8.2 Motor data

Feature	Description
Motor type	Squirrel-cage induction motor
Frequency	50 Hz or 60 Hz
Supply	3-phase
Starting method	Direct on-line Star-delta
Maximum starts per hour	30 evenly spaced starts per hour
Code compliance	IEC 60034-1
Voltage variation without overheating	±10%, if it does not run continuously at full load
Voltage imbalance tolerance	2%
Stator insulation class	H (180°C [360°F])

Motor encapsulation

Motor encapsulation is in accordance with IP68.



Grindex
Gesällvägen 33
174 07 Sundbyberg
Sweden
Tel: +46-8-606 66 00
Fax: +46-8-745 53 28
www.grindex.com

Visit our Web site for the latest version of this document
and more information

The original instruction is in English. All non-English
instructions are translations of the original instruction.

© 2011 Grindex