

Parts List

Bravo 700 — 8151.020/.190



www.grindex.com



Parts List

Bravo 700 — 8151.020/190

Overview

Table of Contents

This publication contains the following topics:

Topic

Introduction	4
Practical Information	5
Data Plate Interpretation.....	6
Order parts.....	10
Motor Parts	11
Non Explosion-proof.....	12
Explosion-proof.....	14
List.....	16
Hydraulic Parts	22
Without Agitator	23
With Agitator.....	24
List.....	25

Introduction

Purpose

The purpose of this manual is to give the reader information about available spare parts and accessories for the product.

Recipient

The manual is principally intended for Grindex

- customers
 - service personnel
 - sales personnel
-

Contact

For more information

- contact your Grindex representative
 - visit <http://www.grindex.com/>
-

Reference

More information about the product is available in the following documents:

- Installation, Operation and Maintenance
 - Grindex accessories list
-

Practical Information

Overview

Table of Contents

This chapter contains the following topics:

Topic	
Data Plate Interpretation	6
Data Plate.....	6
FM approved version	8
EN approved version	9
Order parts	10

Data Plate Interpretation

Introduction

The Grindex product is always provided with data plates:

- The data plate is used on all products.
- The approval plate is added to all explosion proof products.

Data Plate

The product may only be operated within the parameters stated on the data plate.

Illustration

This is the data plate for non explosion-proof version .020:

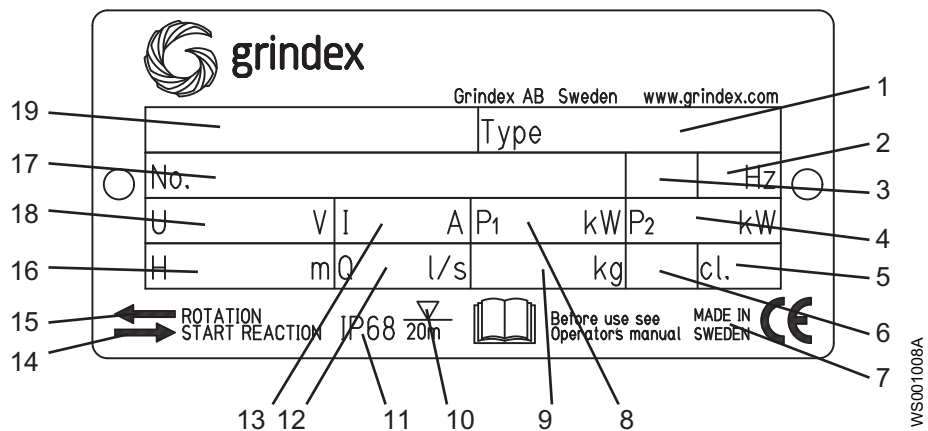

These are the data plates for explosion-proof version .190:

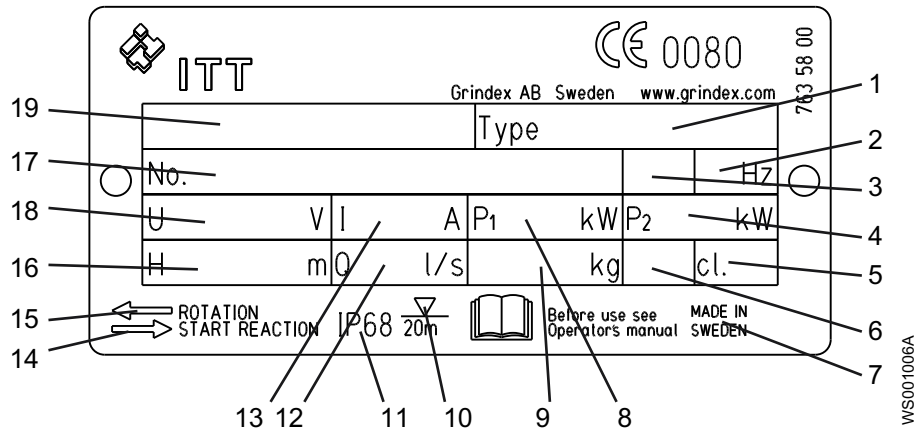

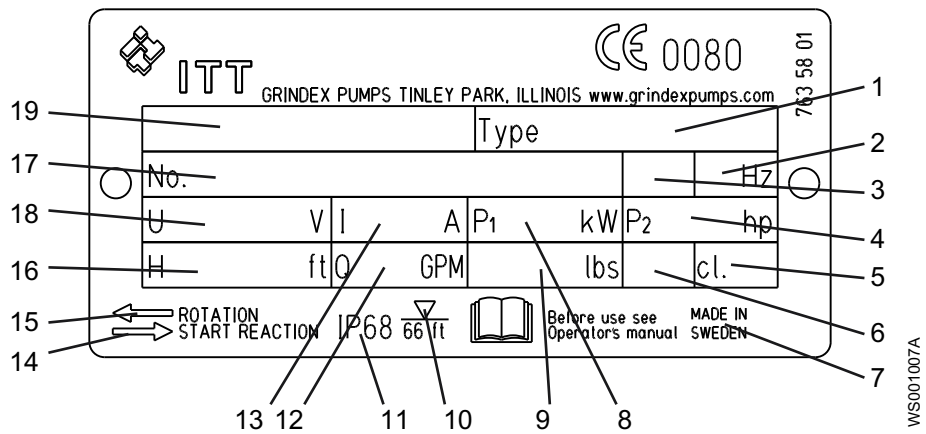

Field description

This table shows the fields on the general data plate, and which information each field contains.

Field	Description	Field	Description
1	Pump type number	11	Degree of protection
2	Frequency	12	Maximum capacity
3	Phases, type of current	13	Rated current
4	Rated shaft power	14	Direction of the start reaction
5	Thermal class	15	Direction of the impeller rotation
6	Locked rotor code-letter	16	Maximum head
7	Country of origin	17	Serial number
8	Maximum power consumption	18	Rated voltage
9	Product weight	19	Pump model
10	Maximum submersion depth	-	-

FM approved version

Illustration

This is an illustration of an approval plate for the FM approved product version.

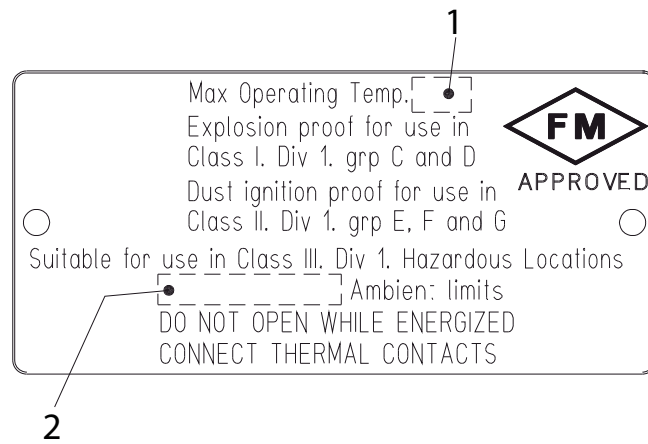

Field description

This table shows the fields on the approval plate, and which information each field contains.

Field	Description
1	Temperature class
2	Maximum ambient temperature

EN approved version

Illustration

This is an illustration of an approval plate for the EN approved product version.

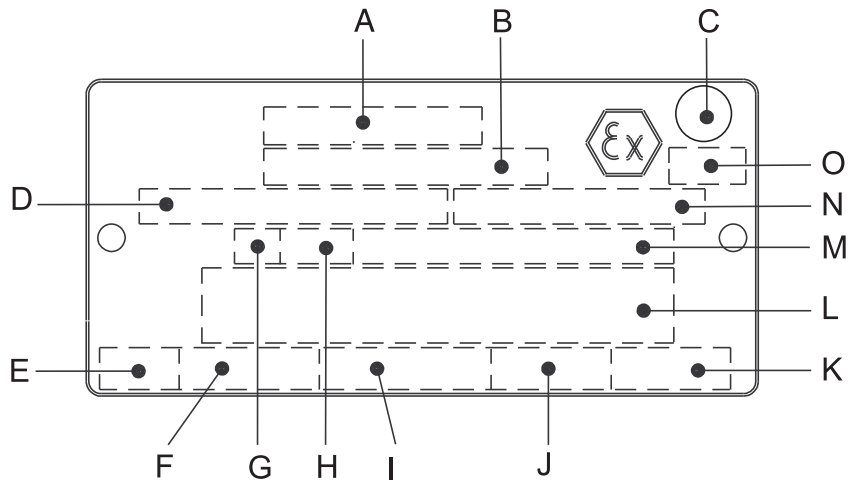

Field description

This table shows the fields on the approval plate.

Field	Description	Field	Description
A	Approval	I	Input power
B	Approval authority + Approval Number	J	Rated speed
C	Approval for Class 1	K	Controller
D	Approved drive unit	L	Additional information
E	Stall time	M	Max. ambient temperature
F	Starting current / Rated current	N	Serial number
G	Duty class	O	ATEX marking
H	Duty factor	-	-

Order parts

Order

When ordering spare parts, state product number and serial number of the product, spare part number and quantity.

Requirements

Genuine Grindex parts must always be used for repairs if the product is to fulfill requirements and obtain official approval.

Specially Approved Products

Spare parts marked with (EX) after the part number are subject to dimensional accuracy inspection.

Motor Parts

Overview

Table of Contents

This chapter contains the following topics:

Topic	
Non Explosion-proof.....	12
Without Cooling Jacket	12
With Cooling Jacket.....	13
Explosion-proof.....	14
Without Cooling Jacket	14
With Cooling Jacket.....	15
List.....	16

Non Explosion-proof

Without Cooling Jacket

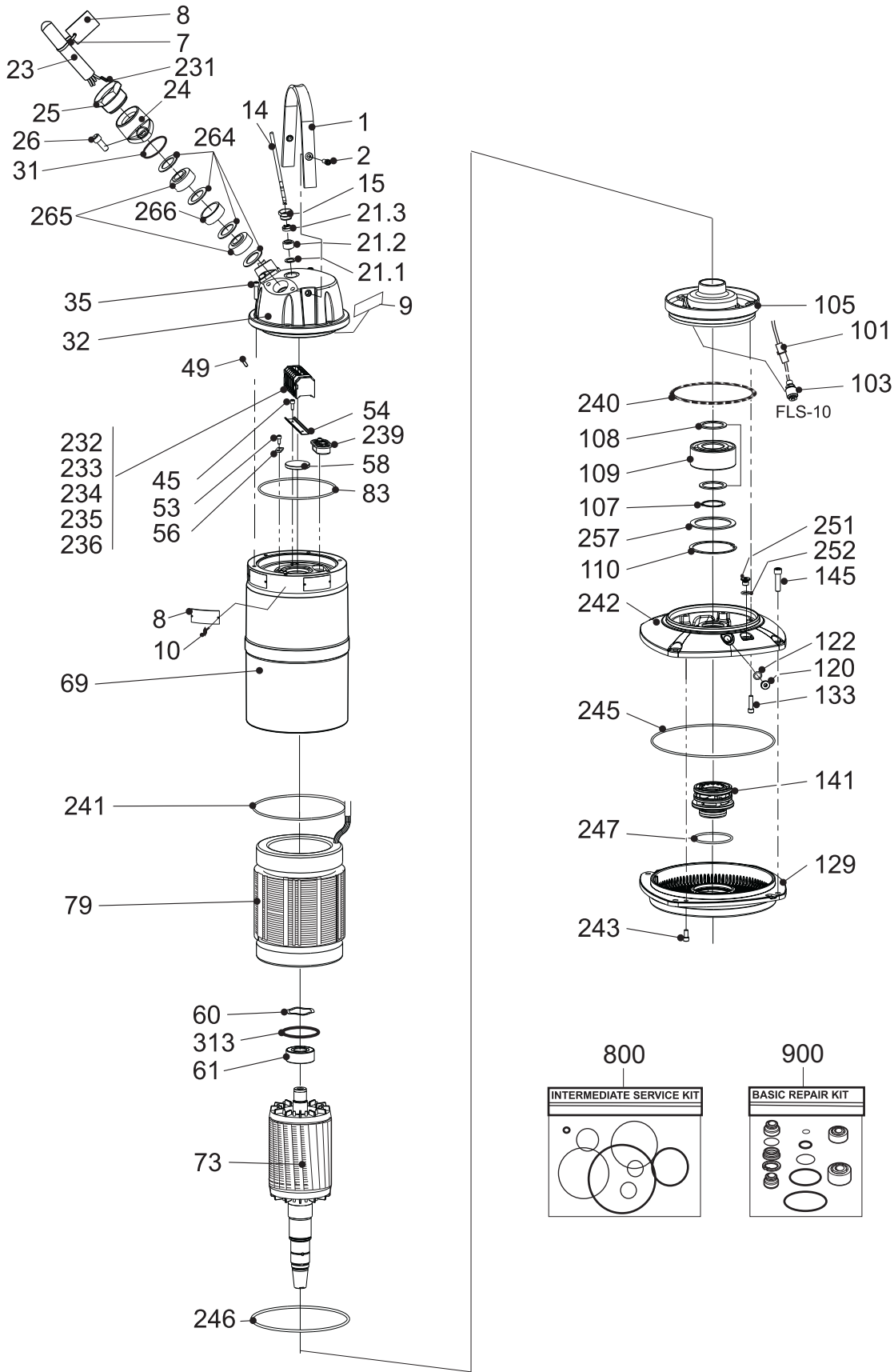

20073B

With Cooling Jacket

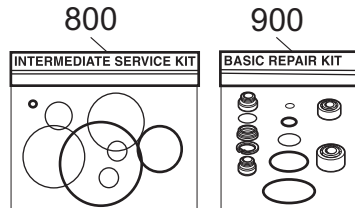
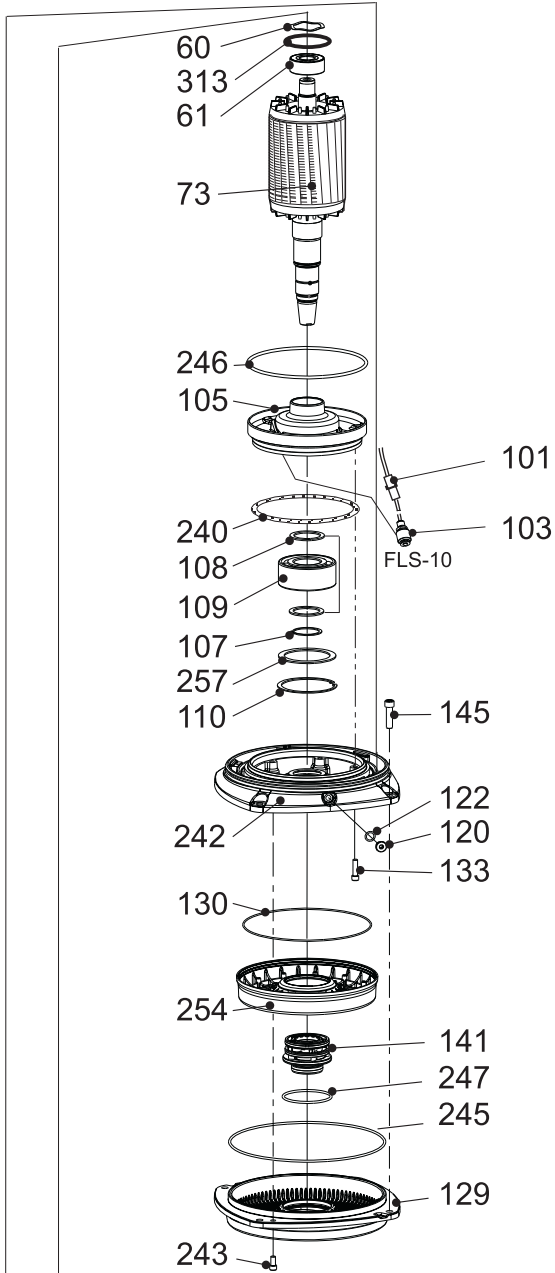
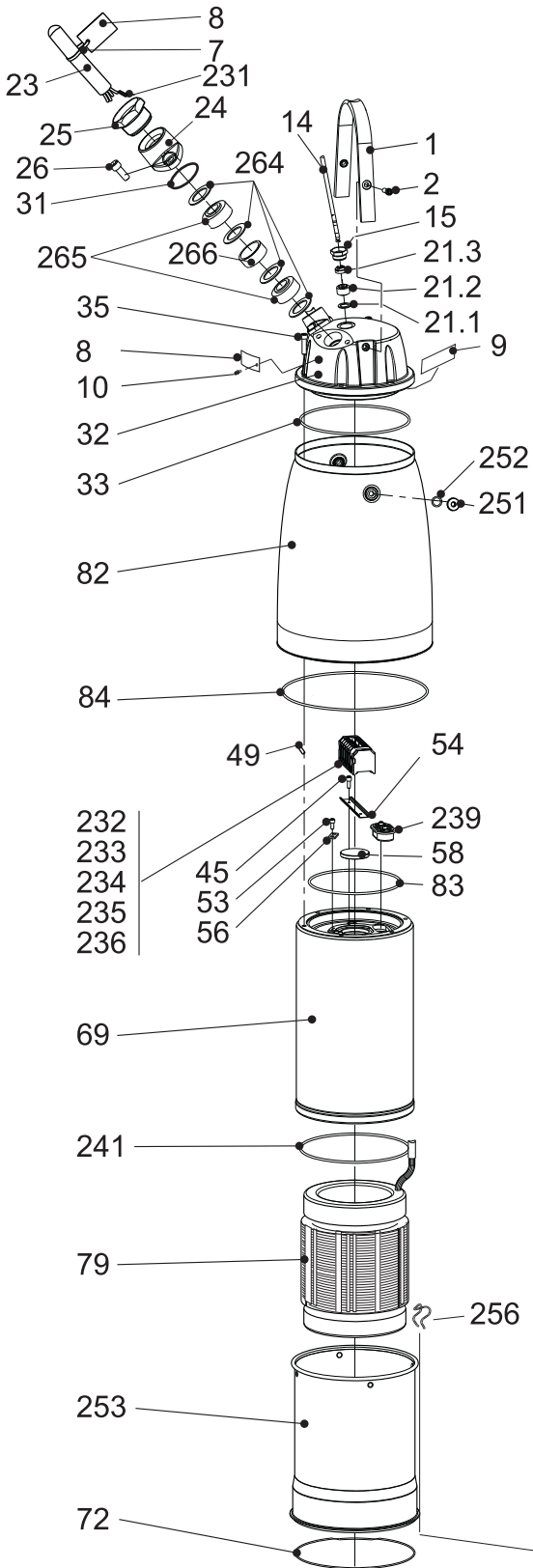

20095B

Explosion-proof

Without Cooling Jacket

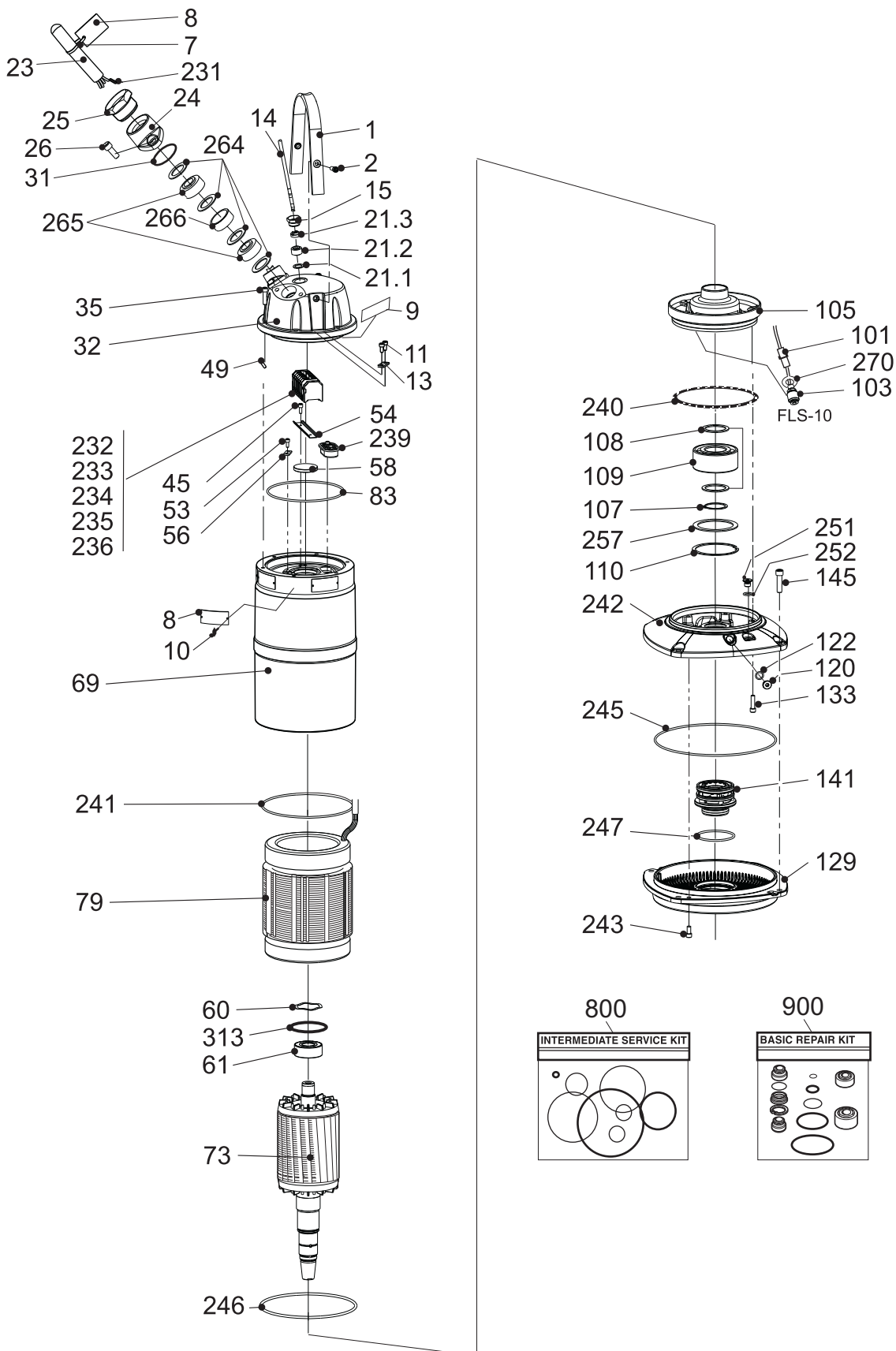

20096B

With Cooling Jacket

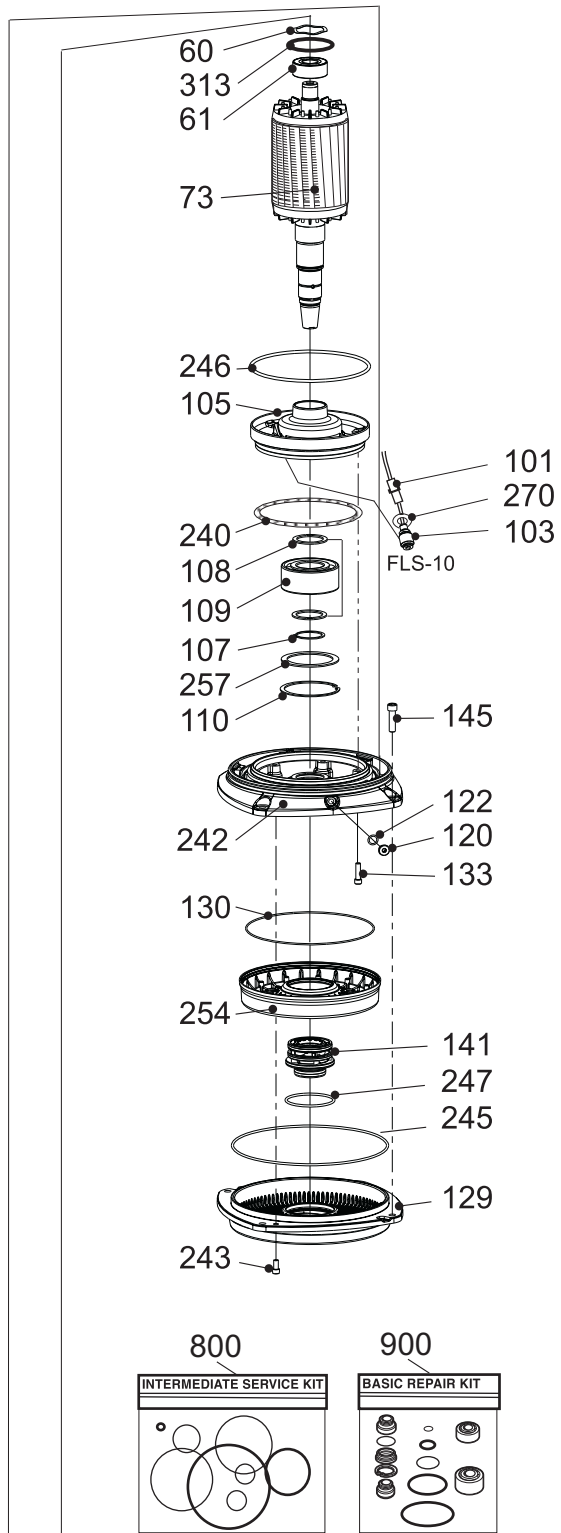
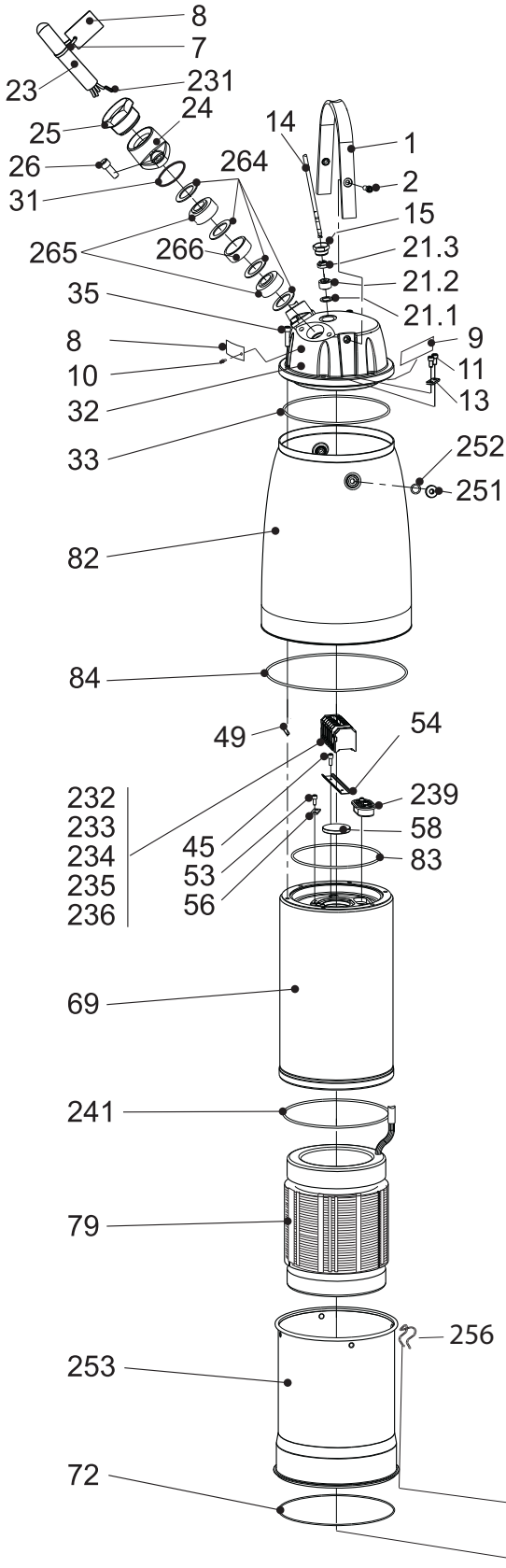

20097B

List

Pos. No	Part. No	Denomination	Qty/Ver- sion	
			020	190
1	51 522 00	Lifting handle	1	1
2	410 374	Hex.socket hd screw M12X45-A4-80 ITT Part. No 83 04 53	2	2
7	410 517	Cable tie 200X2.4 PA 6/6 -55+105	1	1
7	50 457 02	Cable tie 292X3.5;NYLON;+125 C	1	1
8	51 648 00	Certificate plate ITT Part. No 630 69 02		2
8	50 888 00	Plate-blank Use 50 907 00 (EU), 50 907 01 (US) as spare part for non explosion-proof version.	2	2
8	50 888 00	Plate-blank Use 51 633 00 (EU), 51 633 02 (US) as spare part for explosion-proof version. ITT Part. No 763 58 00 and 763 58 01 resp.	2	2
8	51 614 00	Certificate plate ITT Part. No 752 20 00		1
9	410 526	Marking strip 5-GW(T1;T2;T15;T16)	1	1
9	410 527	Marking strip W5;V5;U5;V2;W1;U2;V1;W2;U	1	1
9	50 918 00	Connection plate SCREENED CABLE	1	1
9	51 426 00	Connection plate	1	1
9	51 438 00	Plate	1	1
9	51 440 00	Connection plate	1	1
9	51 441 00	Connection plate	1	1
9	51 509 00	Connection plate	1	1
9	51 531 00	Connection plate	1	1
10	410 000	Drive screw 4X5-A2-70 ITT Part. No 82 20 88	4	4
11	410 503	Hex.socket hd screw M6X12-A2-70 ITT Part. No 82 00 11		2
13	50 902 00	Earthing plate	1	1
14	410 350	Control cable SUBCAB 7X1.5 MM2 OD=15-17	*	*
15	51 407 00	Gland screw FOR CABLE ENTRY ITT Part. No 397 81 00	1	1
21.1	50 127 04	Plain washer (10)-22 MM	1	1
21.2	410 043	Seal sleeve (10)-12 MM	1	1
21.2	410 045	Seal sleeve (14)-16 MM	1	1
21.3	50 926 00	Cable clip (10)-12 MM	1	1
21.3	50 926 02	Cable clip (14)-16 MM	1	1
23	410 063	Motor cable 7G2.5+2X1.5 MM2 OD=20-23	*	*
23	410 125	Motor cable SCREEN S3X10+3X10/3+4X1.5	*	*

Pos. No	Part. No	Denomination	Qty/Version	
			020	190
23	410 126	Motor cable 4G6+2X1.5 MM2 OD=23-25 MM	*	*
23	410 127	Motor cable 4G10+2X1.5 MM2 OD=26-28MM	*	*
23	410 128	Motor cable 4G16+2X1.5 MM2 OD=26-28MM	*	*
23	410 129	Motor cable 4G4+2X1.5 MM2 OD=20-22 MM	*	*
23	410 130	Motor cable 7G4+2X1.5 MM2 OD=22-26 MM	*	*
23	410 131	Motor cable 7G6+2X1.5 MM2 OD=24-28 MM	*	*
23	410 134	Motor cable 8AWG/3-2-1-GC OD=27-29 MM	*	*
23	410 135	Motor cable 6AWG/3-2-1-GC OD=30-32 MM	*	*
23	410 136	Motor cable 4AWG/3-2-1-GC OD=33-35 MM	*	*
23	410 347	Motor cable SUBCAB S3X16+3X16/3+4X1.5	*	*
23	410 351	Motor cable SUBC750RN 4G25+2X1.5	*	*
23	410 352	Motor cable SUBCAB4G35+2X1.5 MM2	*	*
23	410 355	Motor cable SUBCAB 1AWG/3-2-1-GC	*	*
23	410 383	Motor cable SUBCAB S3X25+3X16/3+4X1.5	*	*
23	410 384	Motor cable SUBCAB S3X35+3X16/3+4X1.5	*	*
24	51 411 00 (EX)	Entrance flange SS	ITT Part. No 597 87 01	2 2
24	51 411 01 (EX)	Entrance flange ISO 228/1-G2	ITT Part. No 597 87 04	2 2
24	51 411 02 (EX)	Entrance flange 2-11.5 NPT	ITT Part. No 597 87 08	2 2
24	51 411 03 (EX)	Entrance flange 1 1/2-11.5 NPT	ITT Part. No 597 87 11	2 2
24	51 423 00 (EX)	Entrance flange	ITT Part. No 642 17 01	2 2
25	51 419 00	Gland screw 1 1/4" ISO.FOR METALHOSE	For use with metal hose. ITT Part. No 633 11 01	2 2
25	51 419 01	Gland screw 1 1/2" NPT.FOR METALHOSE	For use with metal hose. ITT Part. No 633 11 04	2 2
26	410 374	Hex.socket hd screw M12X45-A4-80	ITT Part. No 83 04 53	4 4
31	410 086	O-ring 49.5X3 NBR		2 2
31	410 513	O-ring 49.5X3 FPM		2 2
32	51 521 00	Entrance cover	Intended for motor cable x 1	1

Pos. No	Part. No	Denomination		Qty/Ver- sion	
				020	190
32	51 521 01	Entrance cover	Intended for motor cable x 2	1	
32	51 521 02	Entrance cover	Intended for motor cable x 1 + 1 control cable	1	
32	51 521 03	Entrance cover	Intended for motor cable x 2 + 1 control cable	1	
32	51 521 04 (EX)	Entrance cover	Intended for motor cable x 1. ITT Part. No 607 72 11		1
32	51 521 05 (EX)	Entrance cover	Intended for motor cable x 2. ITT Part. No 607 72 13		1
32	51 521 06 (EX)	Entrance cover	Intended for motor cable x 1 + 1 control cable. ITT Part. No 607 72 15		1
32	51 521 07 (EX)	Entrance cover	Intended for motor cable x 2 + 1 control cable. ITT Part. No 607 72 17		1
33	131 543	O-ring 249.3X5.7 NBR		1	1
33	50 037 68	O-ring 249.3X5.7 FPM		1	1
35	410 374	Hex.socket hd screw M12X45-A4-80	ITT Part. No 83 04 53	6	6
45	410 503	Hex.socket hd screw M6X12-A2-70	ITT Part. No 82 00 11	2	2
49	410 515	End sleeve H16/24		6	6
49	410 516	End sleeve H25/30		6	6
49	410 580	End sleeve H35/30D		3	3
49	410 581	End sleeve H50/36		6	6
49	410 611	End sleeve		6	6
53	410 503	Hex.socket hd screw M6X12-A2-70	ITT Part. No 82 00 11	4	4
54	51 518 00	Rail 35X7.5		1	1
56	50 902 00	Earthing plate		1	2
58	410 608	Protective cap VK 80X10		1	1
60	410 600	Spring washer 89.5X72X0.66		1	1
61	410 101	Ball bearing 3308A-2Z/C3VT113		1	1
69	51 520 00	Stator housing		1	
69	51 520 01 (EX)	Stator housing	ITT Part. No 607 65 01		1
72	132 356	O-ring 299.3X5.7 NBR		1	1
72	410 602	O-ring 299.3X5.7 FPM		1	1
73	51 516 00	Shaft unit		1	1
79	51 517 01	Stator 30-24-4a	50Hz: 660 - 690V Y, 380 - 400V D. 60Hz: 440 - 460V D.	1	1
79	51 517 03	Stator 30-24-4a	50Hz: 500V D. 60Hz: 575 - 600V D.	1	1
79	51 517 04	Stator 30-24-4a	60Hz: 460V Yser, 230V Y//.	1	1
79	51 517 05	Stator 30-24-4a	50Hz: 415 - 440V D.	1	1

Pos. No	Part. No	Denomination	Qty/Version	
			020	190
79	51 517 05	Stator 30-24-4a 50Hz: 415 - 440V D. 50Hz: 415 - 440V D.	1	1
79	51 517 07	Stator 30-24-4a 60Hz: 380V D. 60Hz: 380V D.	1	
82	51 636 00	Cooling jacket OUTER	1	1
82	51 636 01	Cooling jacket OUTER	1	1
83	410 092	O-ring 319.3X5.7 NBR	1	1
83	410 570	O-ring 319.3X5.7 FPM	1	1
84	132 411	O-ring 399.3X5.7 NBR	1	1
84	410 603	O-ring 399.3X5.7 FPM	1	1
101	50 698 00	Cable unit FLS10	1	1
103	50 486 01 (EX)	Level sensor FLS10 ITT Part. No 663 04 00	1	1
105	51 524 00	Bearing holder	1	
105	51 524 01 (EX)	Bearing holder ITT Part. No 607 96 01		1
107	410 601	Retaining ring SGA 70	1	1
108	51 530 00	Supporting washer	2	2
109	410 610	Ball bearing 3314A-2Z/C3VT113	1	1
110	410 609	Retaining ring 152/3,25	1	1
120	51 428 00	Plug	1	1
122	410 508	O-ring 17X3 NBR	1	1
122	410 511	O-ring 17X3 FPM	1	1
129	51 523 00	Seal housing cover	1	1
130	410 710	O-ring 329.79X3.53 NBR	1	1
133	410 374	Hex.socket hd screw M12X45-A4-80 ITT Part. No 83 04 53	6	6
141	51 525 00	Mechanical seal	1	1
145	410 553	Hex.socket hd screw M16X60-A4-80 ITT Part. No 83 04 58	4	4
231	410 054	Shrink hose ID 6.4	*	
231	410 122	Shrink hose ID 9.5	*	
232	410 523	Terminal clamp WDU6/10	3	3
233	410 519	Terminal clamp WDU35/IK/ZA	9	9
233	410 524	Terminal clamp WDU16,1000V	8	8
233	410 585	Terminal clamp WEIDMÜLLER WDU 70N	9	9
234	410 520	Cross connection WQW35/2	4	4
234	410 525	Cross connection WQV16/2	4	4
234	410 584	Cross connection WEIDMÜLLER WQV 70N/3	1	1
234	410 586	Cross connection WEIDMÜLLER WQV 70N/2	4	4

Pos. No	Part. No	Denomination	Qty/Version	
			020	190
234	51 427 00	Cross connection	1	1
234	51 427 01	Cross connection	1	1
235	410 522	End support WEW 35/2	2	2
236	410 521	Partition	1	1
239	51 460 00	El.lead through unit	1	1
239	51 460 01	El.lead through unit	1	1
240	51 519 00 (EX)	Spring	ITT Part. No 607 48 01	1
241	410 240	O-ring 269.3X5.7 NBR	1	1
241	410 605	O-ring 269.3X5.7 FPM	1	1
242	51 647 00	adapter	1	
242	51 633 01 (EX)	adapter	ITT Part. No 607 79 01	1
242	51 638 00 (EX)	adapter	ITT Part. No 607 91 11	1
242	51 647 00	adapter	1	
243	50 023 09	Hex.socket hd screw M12X25-A4-80	ITT Part. No 83 04 61	2
245	132 411	O-ring 399.3X5.7 NBR	1	1
245	410 603	O-ring 399.3X5.7 FPM	1	1
246	410 710	O-ring 329.79X3.53 NBR	1	1
247	410 606	O-ring 119.3X5.7 FPM	1	1
251	51 428 00	Plug	2	2
252	410 508	O-ring 17X3 NBR	2	2
252	410 511	O-ring 17X3 FPM	2	2
253	51 634 00	Cooling jacket	1	1
254	51 635 00	Flow diffusor	1	1
256	51 637 00	Wire bow	4	4
257	410 599	Washer SS 120X150X3.5	1	1
264	132 312	Plain washer (33)-35 MM	8	8
264	132 336	Plain washer (20)-32 MM	8	8
264	132 341	Plain washer (37)-39 MM	8	8
264	410 598	Plain washer 44.5X52X2-A2-70	8	8
265	410 114	Seal sleeve (20)-23 MM	2	4
265	410 115	Seal sleeve (23)-26 MM	4	4
265	410 116	Seal sleeve (26)-29 MM	4	4
265	410 117	Seal sleeve (29)-32 MM	4	4
265	410 118	Seal sleeve (32)-35 MM	4	4
265	410 612	Seal sleeve (36)-38 MM	4	4
265	410 613	Seal sleeve (38)-41 MM	4	4
265	410 614	Seal sleeve (41)-43 MM	4	4

Pos. No	Part. No	Denomination	Qty/Version	
			020	190
266	51 025 02	Ring	2	2
270	51 118 00	Lock washer		1
313	410 604	O-ring 89.5X3 FPM	1	1
800	410 697	O-ring kit	1	1
900	51 619 03	Basic repair kit	1	1
912	410 508	O-ring 17X3 NBR	3	3
912	410 511	O-ring 17X3 FPM	3	3
		Extra O-rings for Inspection screws		
		Extra O-rings for Inspection screws		

* piece goods

Hydraulic Parts

Overview

Table of Contents

This chapter contains the following topics:

Topic

Without Agitator	23
With Agitator	24
List.....	25

Without Agitator

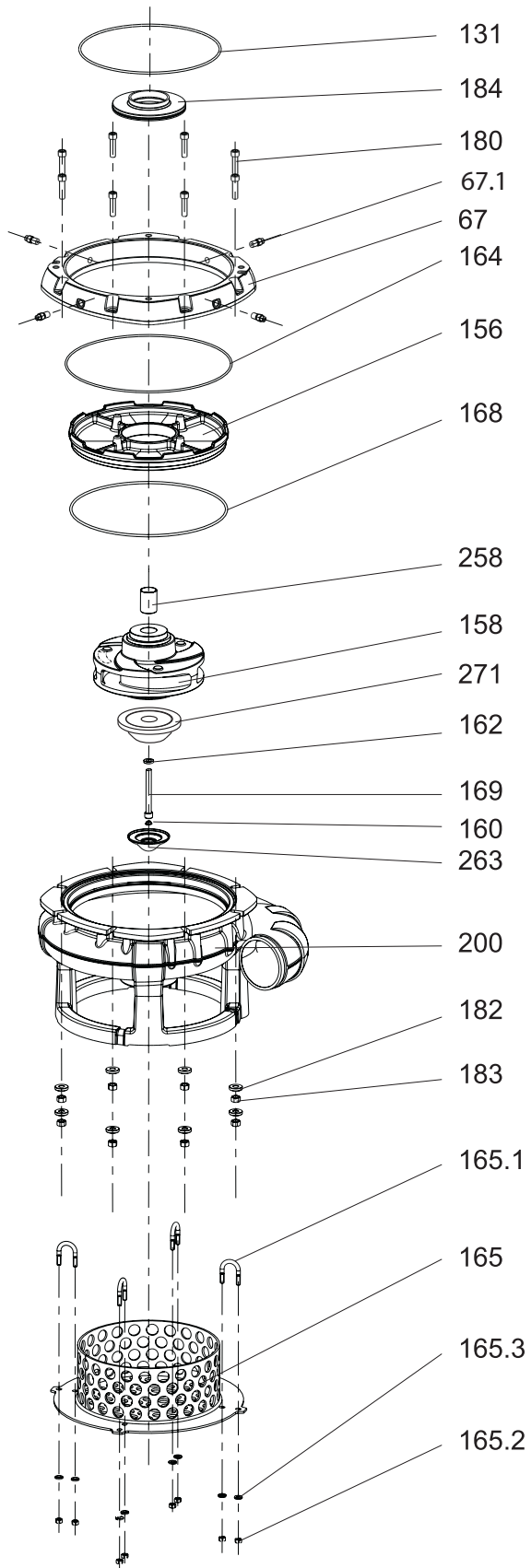

20075A

With Agitator

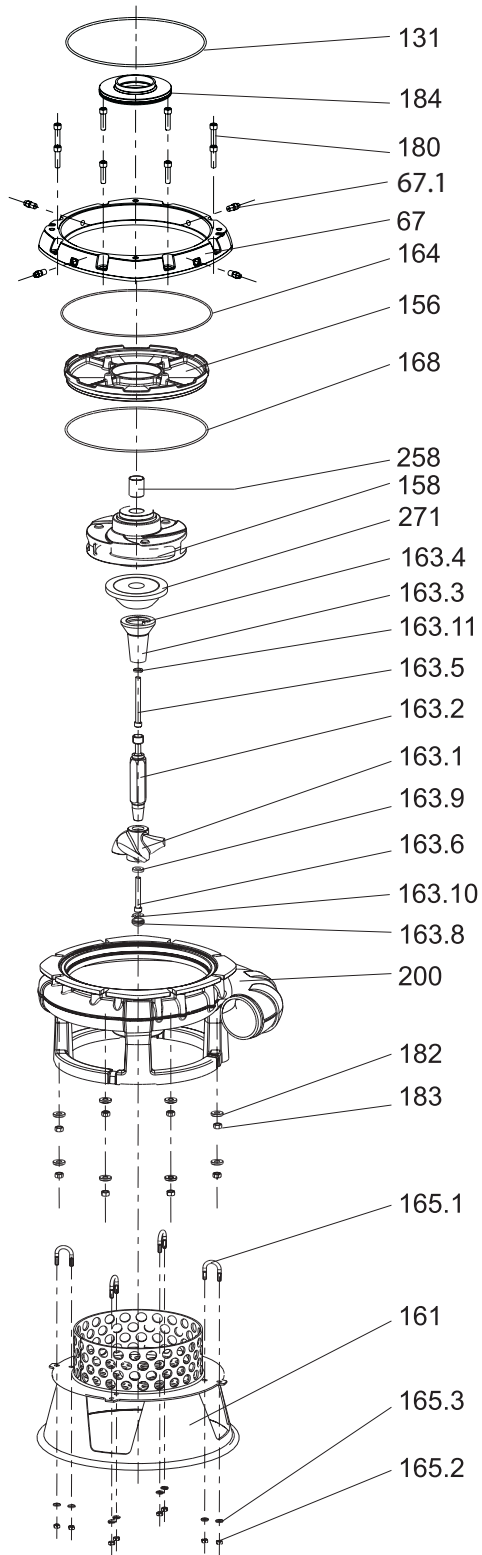

20076A

List

Pos. No	Part. No	Denomination	Qty/Version		
			020	190	
67	51 528 00	adapter	1	1	
67.1	51 599 00	Nozzle	4	4	
131	132 411	O-ring 399.3X5.7 NBR	1	1	
131	410 603	O-ring 399.3X5.7 FPM	1	1	
156	51 500 00	Wearing cover	1	1	
158	51 508 51	Impeller 50Hz.	1	1	
158	51 508 52	Impeller 60Hz.	1	1	
160	50 437 00	Protective plug F11	1	1	
161	51 501 00	Stand compl.	1	1	
162	410 557	Plain washer STAINLESS STEEL A4	1	1	
163	51 505 01	Agitator unit	1	1	
163.1	51 412 00	Propeller	1	1	
163.11	410 557	Plain washer STAINLESS STEEL A4	1	1	
163.2	51 513 00	Shaft	1	1	
163.3	51 502 00	Barrel nut	1	1	
163.4	410 556	Tension pin	1	1	
163.5	410 607	Hex.socket hd screw M16X180-A4-70	ITT Part. No 83 03 87	1	1
163.6	410 577	Hex.socket hd screw M16X120-A4 80	ITT Part. No 83 04 60	1	1
163.8	51 406 00	Plug	1	1	
163.9	51 417 00	Washer	1	1	
164	410 242	O-ring		1	
164	410 565	O-ring	1		
165	51 514 00	Strainer compl.	1	1	
165.1	51 600 00	Bracket	4	4	
165.2	132 280	Hexagon nut M12-A2-70	8	8	
165.3	132 424	Plain washer 12-A2-170	8	8	
168	410 242	O-ring	1		
168	410 565	O-ring		1	
169	410 597	Hex.socket hd screw	ITT Part. No 82 01 19	1	1
180	410 553	Hex.socket hd screw M16X60-A4-80	ITT Part. No 83 04 58	8	8
182	51 470 00	Plain washer	8	8	
183	132 256	Hexagon nut M16-A2-70	8	8	
184	51 529 00	Wear protection	1	1	
200	51 496 00	Pump housing	1	1	

Pos. No	Part. No	Denomination	Qty/Version	
			020	190
258	51 532 00	Sleeve unit	1	1
263	51 497 00	Wear protection	1	1
271	51 498 00	Sleeve	1	1



Grindex AB • Box 7025 • SE-174 07 Sundbyberg • Sweden • Tel +46 8 606 66 00 • Fax +46 8 745 53 28 • marketing@grindex.com

© Grindex AB. The original instruction is in English. All non-English instructions are translations of the original instruction.