

# Spare Parts List

# MIDI

# PROLINE

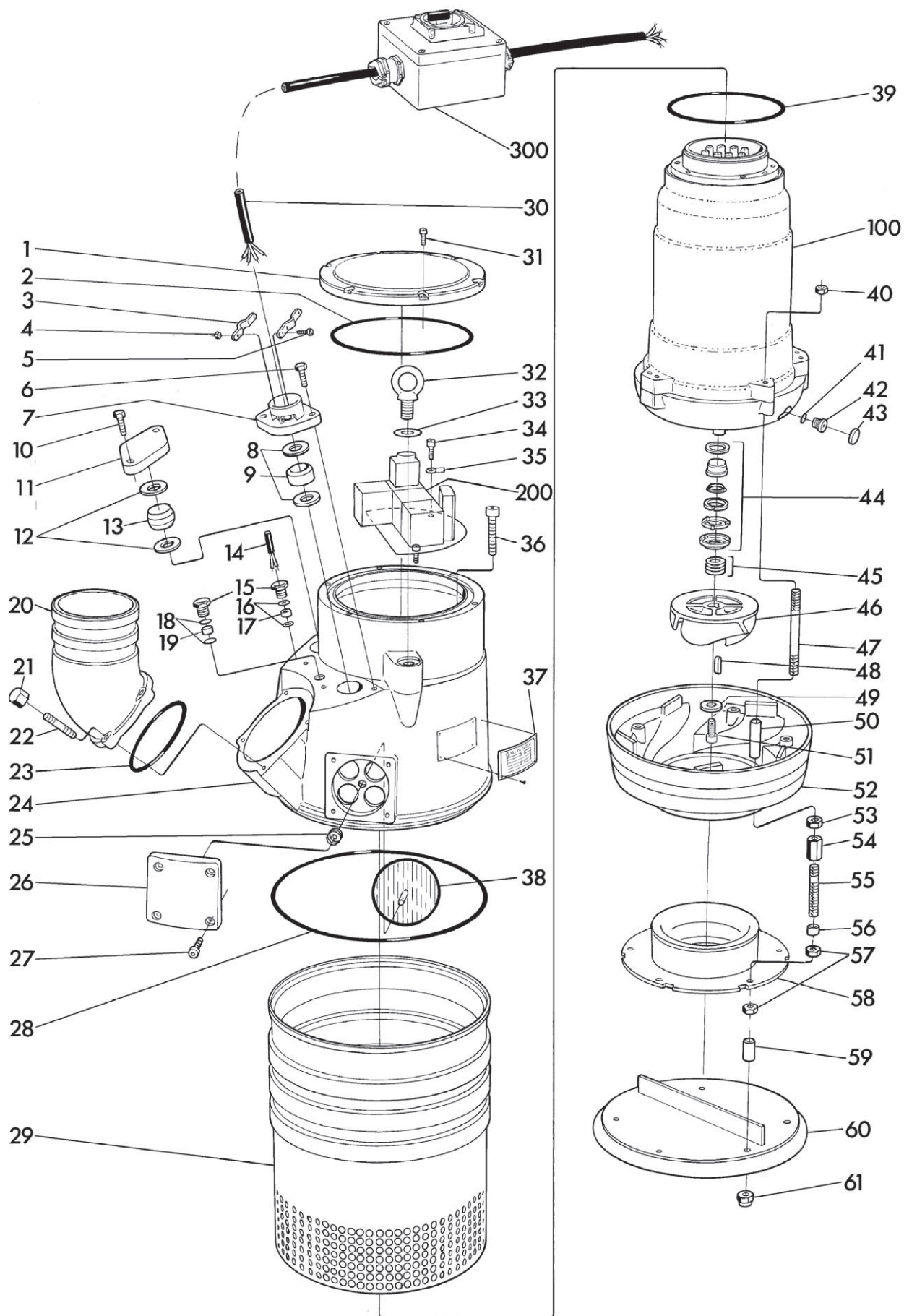

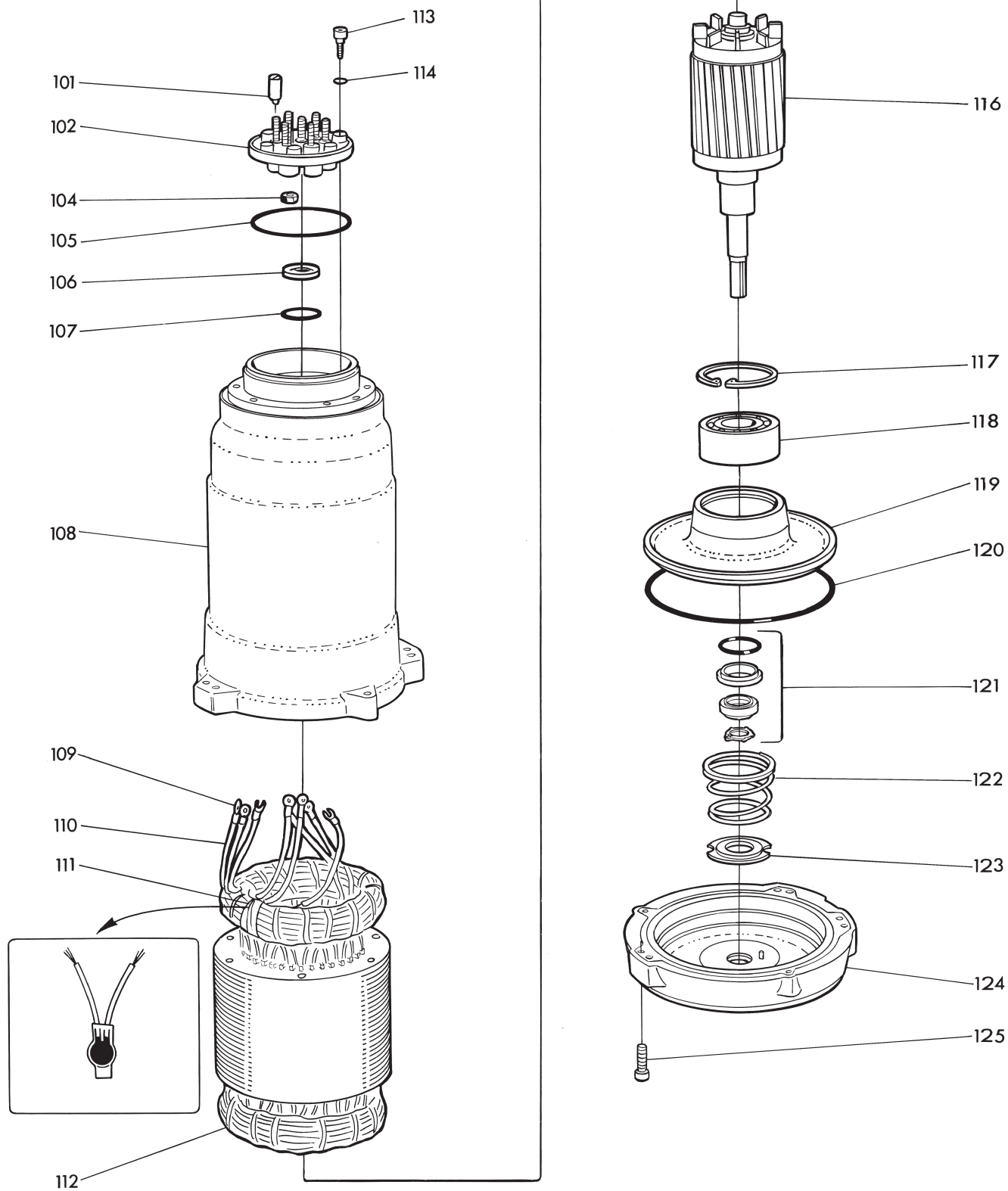

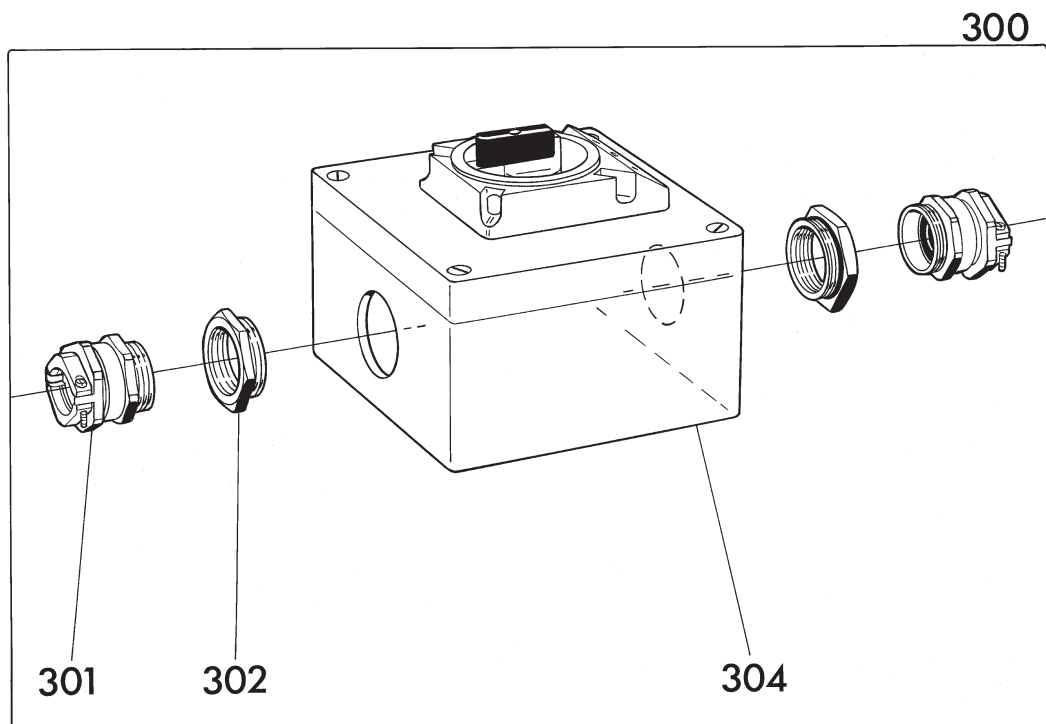
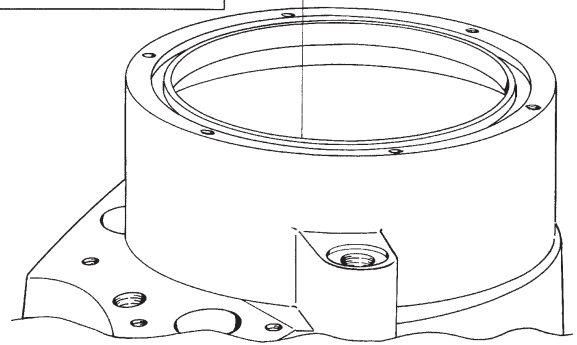
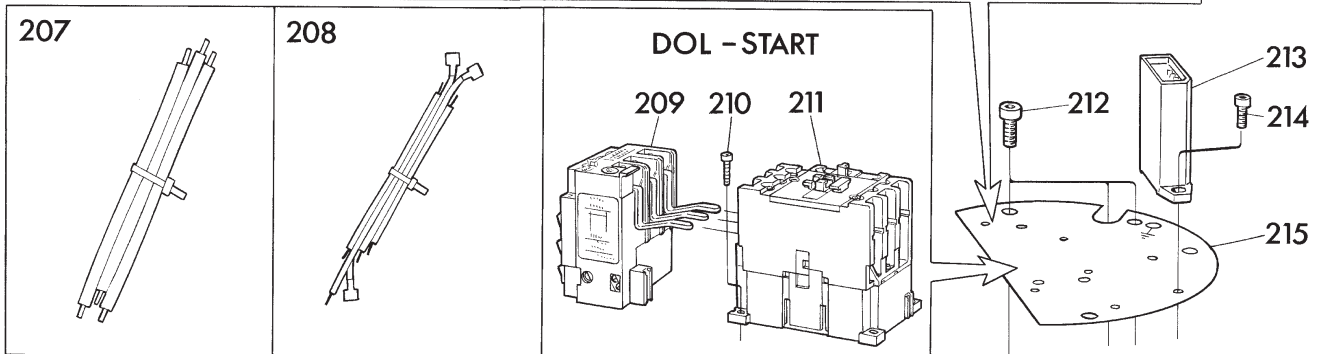
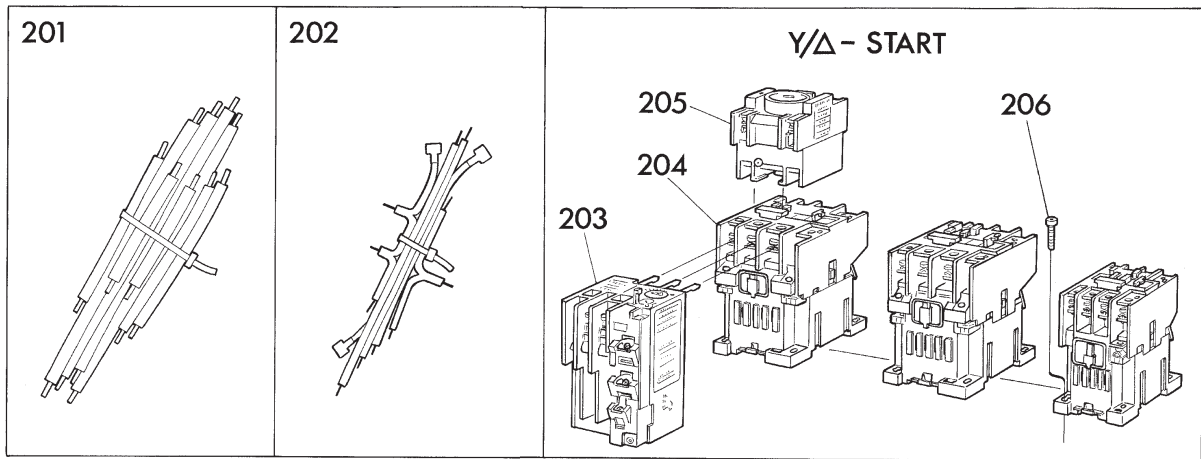

Reservdelslista	Spare Parts List	Ersatzteilliste	Liste des pièces de rechange
<b>Midi N Type G39xx</b>		<b>Midi H Type G40xx</b>	
N= Normalutförande Regular version Normalausführung Version normale		H= Högtrycksutförande High Head version Hochdrucksausführung Version haute pression	

PU	GU	RF	ST	VJ	FZ	AL	ZA
Polyurethan	Gummi	Rostfritt stål	Stål	Vitjärn	Förzinkad	Aluminium	Zinkanoder
Polyurethane	Rubber	Stainless steel	Steel	White iron	Galvanized	Aluminum	Zinc anodes
Polyurethan	Gummi	Rostfreier Stahl	Stahl	Chromlegierter Hartguss	Galvanisiert	Aluminium	Zinkanoden
Polyuréthane	Caoutchouc	Acier inoxydable	Acier	Fonte blanche alliée au chrom	Galvanisé	Aluminium	Anodes sacrificielles

Pos. nr.	Item No.	Detailnr.	Antal				
Pos-Nr	Part No.		Quantity				
No. de repérage	Bestell-Nr.		Anzahl				
No de pièce	Benämning	Denomination	Bezeichnung	Désignation	Nombre		
1	50 066 02	Lock	Cover	Deckel	Couvercle	1	
2	50 037 03	O-ring 239,1x8,4	O-ring	O-Ring	Anneau torique	1	
		Kabelgenomföring vid kabel Ø	Cable entry at cable O.D.	Kabeleinführung bei Kabeldurchmesser	Entrée de câble avec un câble Ø		
		Ø(14)-16mm	Ø(16)-18mm	Ø(18)-20mm	Ø(22)-24mm	Ø(24)-26mm	Ø(26)-28mm
3	50 216 01	131 942	131 942	131 942	131 942	131 942	(2)
4	131 402	131 402	131 402	131 402	131 402	131 402	(2)
5	131 961	131 961	131 961	131 961	132 327	132 327	(2)
6	132 407	132 407	132 407	132 407	132 407	132 407	(2)
7	132 340	132 340	132 340	132 340	132 340	132 340	(1)
8	50 016 06	131 983	131 924	132 320	131 934	131 950	(2)
9	50 015 06	131 982	131 922	132 331	131 933	131 935	(1)
10	132 407	Skruv M12x30	Screw	Schraube	Vis		(2)
11	132 394	Täcklock	Cover	Deckel	Couvercle		(1)
12	131 950	Tättningsbricka	Washer	Scheibe	Rondelle		(2)
13	132 453	Propp	Plug	Pfropfen	Bouchon		(1)
14		Kabel (ange längd)	Cable (state length)	Kabel (Länge angeben)	Câble (indiquer longueur)		
	130 963	2x1.5mm- (H07RN-F Ø8,5-11mm)					
15	132 343	Hylsskruv	Gland screw	Verschraubung	Vis		(1)
16	132 344	Tättningsbricka	Washer	Scheibe	Rondelle		(2)
17	132 345	Gummikuts	Rubber seal	Gummidichtung	Manchon		(1)
18	132 455	Bricka	Washer	Scheibe	Rondelle		(2)
19	132 454	Propp	Plug	Pfropfen	Bouchon		(1)
20		Tryckanslutning	Discharge connection	Druckanschluss	Coude de refoulement		1
	<b>N</b>		<b>H</b>				
	130 729	6"	131 111	4"			
	131 103	R6" BSP female	131 102	R4" BSP male			
	50 352 00	NPT 6-8 female	50 350 00	NPT 4-8 male			
21	140 089	Kupolmutter	Domed nut	Mutter	Ecrou		4
22	130 731	Pinnskruv M10x45	Stud	Stiftschraube	Goujon		4
23	130 944	O-ring 149,3x5,7	O-ring	O-Ring	Anneau torique		1
24	50 067 03	Överdel	Main cover	Hauptdeckel	Couvercle		1
25	130 752	Fjäder	Spring	Feder	Ressort		2
26	50 074 00	Lock	Cover	Deckel	Couvercle		2
27	50 021 00	Skruv M8x25	Screw	Schraube	Vis		8
28	130 946	O-ring 370x5	O-ring	O-Ring	Anneau torique		1
29	50 068 01	Mantel	Outer casing	Aussenmantel	Enveloppe ext.		1

Item No.	Part No.	Benämning	Denomination	Bezeichnung	Désignation	Quantity
30		Kabel extern starter (ange längd)	Cable extern.starter (state length)	Kabel extern.Starter (Länge angeben)	Câble démarreur ext. (indiquer longueur)	(1-2)
	133 139	4x4mm (H07RN-F Ø14-17,9mm)		346-575V Dol & 220-575V Y/D		
	131 028	4x6mm (H07RN-F Ø15,7-20mm)		–		
	131 027	4x10mm (H07RN-F Ø20,9-26,5mm)		220-230V DOL		
	131 026	4x16mm (H07RN-F Ø23,8-30,1mm)		–		
30		Kabel inb. starter (ange längd)	Cable built-in starter (state length)	Kabel eingeb.Starter (Länge angeben)	Câble démarreur incorp. (indiquer longueur)	
	133 139	4x4mm (H07RN-F Ø14-17,9mm)		346-575V		
	131 028	4x6mm (H07RN-F Ø15,7-20mm)		–		
	131 027	4x10mm (H07RN-F Ø20,9-26,5mm)		220-230V		
	131 026	4x16mm (H07RN-F Ø23,8-30,1mm)		–		
		Gäller upp till 20m längd. Vid annan längd kontakta Grindex.	Refers to length of 20m. For other lengths please contact Grindex.	Bezieht sich auf Länge von 20 Metern. Für andere Längen bitte fragen Sie Grindex.	Concernant longueur de 20 metres. Pour autres longueurs consultez Grindex.	
31	50 021 10	Skruv M8x40	Screw	Schraube	Vis	6
32		Lyftögla M20	Eye bolt	Ringschraube	Vis à oreille	2
	50 083 01	FZ				
	50 083 02	RF				
33	50 174 00	Justerbricka	Washer	Justierscheibe	Rondelle de réglage	2-4
34	140 049	Skruv M8x16	Screw	Schraube	Vis	(1-2)
35		Kabelsko (jordkabel)	Lug (earth cable)	Kabelschuh (Erdkabel)	Cosse (câble de terre)	(1-2)
	131 797	4-6 mm-kabel	Cable 4-6 mm	Kabel 4-6 mm	Câble 4-6 mm	
	131 137	10 mm-kabel	Cable 10 mm	Kabel 10 mm	Câble 10 mm	
	131 799	16 mm-kabel	Cable 16 mm	Kabel 16 mm	Câble 16 mm	
36	130 957	Skruv M12x30	Screw	Schraube	Vis	8
37	50 010 05	Dataskylt, ostämpl.	Data plate, blank	Datenschild, ungepr.	Plaque signalétique, vide	1
38	130 745	Ventil	Valve	Ventil	Soupape	2
39	132 314	O-ring 189,3x5,7	O-ring	O-Ring	Anneau torique	1
40	130 955	Mutter M10	Nut	Mutter	Ecrou	5
41	140 077	O-ring 12,37x2,62	O-ring	O-Ring	Anneau torique	1
42	140 034	Skruv	Screw	Schraube	Vis	1
43	130 985	Skyddsbricka	Protection disc	Schutzscheibe	Rondelle de protection	1
44	50 420 00	Axeltätningssats, undre	Shaft seal kit, lower	Wellendichtung, unt.,Satz	Joint mécanique, inf. jeu	1
45	140 026	Justerbricka	Adjusting washer	Justierscheibe	Rondelle de réglage	5-11
46		Pumphjul	Impeller	Laufgrad	Roue	1
		<b>50Hz</b>		<b>60Hz</b>		
N	131 951	Ø159mm (Ø6.3in) VJ		131 979	Ø137mm (Ø5.4in) VJ	
N	131 951RF	Ø159mm (Ø6.3in) RF		131 979RF	Ø137mm (Ø5.4in) RF	
H	131 575	Ø229mm (Ø9.0in) VJ		131 956	Ø226mm (Ø8.9in) VJ	
H	131 575RF	Ø229mm (Ø9.0in) RF		131 956RF	Ø226mm (Ø8.9in) RF	
47		Pinnskruv	Stud	Stiftschraube	Goujon	5
N	131 919	M10x145 mm				
H	132 940	M10x125 mm				
48	50 205 02	Plattkil 5x5x40	Key 5x5x40	Keil 5x5x40	Clavette 5x5x40	1
49	133 147	Bricka	Washer	Scheibe	Rondelle	1
50		Distansrör	Distance tube	Distanzhülse	Tube d'écartement	5
N	132 533	17/11x63				
H	131 923	17/11x50				
51	133 148	Skruv	Screw	Schraube	Vis	1
52		Diffusorring	Diffuser ring	Diffusorring	Anneau diffuseur	1
N	131 996	GU+ST				
H	131 994	GU+ST				
53	130 955	Mutter M10	Nut	Mutter	Ecrou	5
54	50 022 06	Mutter M10x27	Nut	Mutter	Ecrou	5

Item No.	Part No.	Benämning	Denomination	Bezeichnung	Désignation	Quantity
55		Pinnskruv	Stud	Stiftschraube	Goujon	5
N	131 920	M10x95				
H	131 917	M10x110				
56	130 836	Skyddshylsa 19/15x12	Rubber sleeve	Schutzhülse	Douille	5
57	130 955	Mutter M10	Nut	Mutter	Ecrou	10
58		Diffusor, undre	Diffuser, lower	Diffusor, unterer	Diffuseur, inférieur	1
N	131 997	GU+ST				
N	131 995PU	PU+ST				
H	131 995	Gu+ST				
H	131 995PU	PU+ST				
59		Skyddshylsa	Rubber sleeve	Schutzhülse	Douille	5
N	131 648	15/19x43				
H	131 658	15/19x55				
60		Bottenplatta	Strainer bottom	Siebboden	Fond de crépine	1
	50 071 00	FZ				
	50 071 01	RF				
	131 984	RF+ZA				
61	50 131 00	Låsmutter	Nut	Mutter	Ecrou	5
100		Motorenhet	Motor unit	Motoreinheit	Moteur complet	
		Endast Sverige	Only for Sweden	Nur für Schweden	Pour la Suède seulem	
	50 093 00	380/660V				
	50 093 01	500-550V D				
	132 224	Kopplingsplint, kompl.	Terminal board assy.	Klemmenbrett, kompl.	Plaque à bornes, compl.	1
101	132 353	Mutter	Nut	Mutter	Ecrou	(7)
102	50 158 00	Kopplingsplint	Terminal board	Klemmenbrett	Plaque à bornes	(1)
104	140 055	Mutter M8	Nut	Mutter	Ecrou	(6)
-	130 996	Kopplingsbleck	Jumper strip	Schaltlasche	Barrette	(4)
105	140 072	O-ring 126,0x3,0	O-ring	O-Ring	Anneau torique	1
106	140 326	Lock	Cover	Deckel	Couvercle	1
107	140 323	O-ring 47,63x3,53	O-ring	O-Ring	Anneau torique	1
108	50 072 02	Statorhus	Stator housing	Statorgehäuse	Logement de stator	1
109		Kabelsko	Lug	Kabelschuh	Cosse	(8)
	131 187	0,75-1,5 mm kabel	0,75-1,5 mm cable	0,75-1,5 mm-Kabel	Câble 0,75-1,5 mm	
	132 929	2.5 mm kabel	2.5 mm cable	2,5 mm Kabel	Câble 2,5 mm	
	131 797	4-6 mm kabel	4-6 mm cable	4-6 mm Kabel	Câble 4-6 mm	
110	130 689	Systoflexrör 12x100	Insulating tube	Isolierschlauch	Gaine isolante	4
111	140 315	Termokontakt	Thermal contact	Thermokontakt	Contact thermique	3
112		Stator inkl pos 111	Stator incl item 111	Stator mit Pos. 111	Stator avec pos. 111	1
	<b>50Hz</b>		<b>60Hz</b>			
	131 858	200/346V	131 857	220/380V		
	131 988	346/600 V	131 856	380/660V		
	131 850	220-240/380-415V	131 850	230/460V		
	131 851	380-415/660-719V	131 851	460V D		
	131 853	500-550V D	131 854	575V D		
113	130 732	Skruv	Screw	Schraube	Vis	6
114	131 609	O-ring 5x28x1,78	O-ring	O-Ring	Anneau torique	6
115	140 337	Kullager, övre	Ball bearing, upper	Kugellager, oberes	Roulement à billes, sup.	1
116	131 976	Rotorenhet	Rotor unit	Rotoreinheit	Rotor complet	1
117	131 949	Låsring	Circlip	Nutring	Circlip	1
118	132 888	Kullager, undre	Ball bearing, lower	Kugellager, untes	Roulement à billes, inf.	1
119	50 570 00	Lagerhållare	Bearing holder	Lagerhalter	Logement de roulement	1
120	130 947	O-ring 229,3x5,7	O-ring	O-Ring	Anneau torique	1
121	50 534 00	Axeltätningssats, övre	Shaft seal kit, upper	Wellendichtung, ob.,Satz	Joint mécanique, sup. jeu	1
122	50 559 01	Fjäder	Spring	Feder	Ressort	1
123	50 573 00	Tryckplatta	Thrust plate	Druckscheibe	Plaque de pression	1
124	50 579 00	Diffusor, övre	Diffuser, upper	Diffusor, oberer	Diffuseur, supérieur	1



Item No.	Part No.	Benämning	Denomination	Bezeichnung	Désignation	Quantity
125	140 050	Skruv M8x30	Screw	Schraube	Vis	3
201		Huvudkabelsats Y/D	Supply cable set Y/D	Hauptkabelsats Y/D	Jeu du câble principal Y/D	(1)
	50 218 02	220-230V (6mm)				
	50 218 00	346-575V (2,5 mm)				
202	50 220 00	Manöverkabelsats	Pilot cable set	Pilotkabelsats	Jeu du câble de commande 1	
203		Överströmsrelä	Overload relay	Überstromselbst auslöser	Relais de sur- intensité	(1)
	<b>50Hz</b>		<b>60Hz</b>			
	50 354 02	220-230V	50 354 03	220-230V		
	50 354 01	346-415V	50 354 01	380-460V		
	50 354 00	500-550V	50 354 00	575V		
204		Kontaktor	Contacteur	Kontaktor	Contacteur	(3)
	<b>50Hz</b>		<b>60Hz</b>			
	50 353 24	220-230V	50 353 35	230V		
	50 353 21	346V	50 353 21	380V		
	50 353 17	380-415V	50 353 22	460V		
	50 353 11	500-550V	50 353 19	575V		
205	50 355 00	Tidrelä	Time relay	Relais	Relais	(1)
206	50 018 00	Skruv M4x12	Screw	Schraube	Vis	(6)
207		Huvudkabelsats Dol	Supply cable set Dol	Hauptkabelsats Dol	Jeu du câble principal Dol	(1)
	50 217 03	220-230V (10 mm)				
	50 217 01	346-575V (4 mm)				
208	50 219 00	Manöverkabelsats	Pilot cable set	Pilotkabelsats	Jeu du câble de commande	(1)
209		Överströmsrelä	Overload relay	Überstromselbst auslöser	Relais de sur- intensité	(1)
	<b>50Hz</b>		<b>60Hz</b>			
	50 354 05	220-230V	50 354 05	220-230V		
	50 354 03	346V	50 354 03	380V		
	50 354 02	380-415V	50 354 02	460-575V		
	50 354 01	500V				
210		Skruv	Screw	Schraube	Vis	
	50 018 00	M4x12				(2)
	133 743	M6x8				(3)
211		Kontaktor	Contacteur	Kontaktor	Contacteur	(1)
	<b>50Hz</b>		<b>60Hz</b>			
	50 353 41	220-230V	50 353 44	230V		
	50 353 36	346V	50 353 36	380V		
	50 353 25	380-415V	50 353 37	460V		
	50 353 27	500-550V	50 353 27	575V		
212	140049	Skruv M8x16	Screw	Schraube	Vis	(5)
213		Motorskydd	Motor protector	Motorschutzschalter	Disjoncteur	(1)
	<b>50 Hz</b>		<b>60 Hz</b>			
	50 034 00	190-240V	50 034 03	190-240V		
	50 034 01	346-460V	50 034 04	346-460V		
	50 034 02	500-575V	50 034 05	500-575V		
214	50 018 00	Skruv M4x12	Screw	Schraube	Vis	(2)
215	50 075 01	Montageplåt	Mounting plate	Montageblech	Plaque pour montage	(1)

Item No.	Part No.	Benämning	Denomination	Bezeichnung	Désignation	Quantity
300		Fasväxlare inb. starter	Phase shifter built-in starter	Phasenwechsler eingeb. Starter	Renverseur de phases démarreur incorporé	
	(4x4mm) Ø13-20 mm 346-575V	(4x10mm) Ø14-28 mm 220-230V				
301	133 843	133 845				2
302	–	–				
304	50 102 01	50 102 02				1
		Kopplingsschema	Wiring diagram	Schaltschema	Schéma des connexions	
	50 286 00	Y/D	Y/D	Y/D	Y/D	
	50 286 01	Y/D med vippa	Y/D with regulator	Y/D mit Niveauregler	Y/D avec régulateur	
	50 286 02	DOL	DOL	DOL	DOL	
	50 286 03	DOL med vippa	DOL with regulator	DOL mit Niveauregler	DOL avec régulateur	
	50 286 04	Utan inbyggt motorskydd	Without built-in motor protection	Ohne eingebauten Motorschutz	Sans protection de moteur incorporée	
	50 085 03	O-ringsats bestående av:	Set of O-rings comprising:	O-Ringsatz bestehend aus:	Anneaux toriques jeu comprenant:	
2	50 037 03	(1)	23	130 944	(1)	
28	130 946	(1)	39	132 314	(1)	
41	140 077	(1)	105	140 072	(1)	
107	140 323	(1)	114	131 609	(6)	
120	130 947	(1)				
	5055310	Skruvskyddsats	Screw cap kit	Schraubenkappe satz	Kit de chapeaux de vis	
		Olja	Oil	Öl	Huile	1.10L
		Vitolja	White oil	Weißöl	Huile cristalline	
		Viskositet ISO VG 15	Viscosity ISO VG 15	Viskosität ISO VG 15	Viscosité ISO VG 15	

Specifications can be changed without notice.

**GRINDEX**

Grindex AB	Box 538	SE-136 25 Haninge	Sweden
Tel:+46 8 606 66 00		Fax:+46 8 745 16 06	
e-mail: grindex@grindex.com		www.grindex.com	