

# 2

**MANUAL**

**EDILGRAPPA**

**MACHINE BODY  
WITH INTERCHANGEABLE HEADS  
MU22N  
USE AND MAINTENANCE  
INSTRUCTIONS**

**MU22N MACHINE BODY WITH INTERCHANGEABLE HEADS****AVAILABLE IN THE FOLLOWING VERSIONS:**

- **MU22N SINGLE-PHASE ELECTRIC MOTOR 230 V 50 Hz P/N 1.50.1952**

<b>AVAILABLE HEADS</b>	<b>NAME</b>	<b>P/N</b>
T22	CUTTING HEAD	1.50.117
P22	CUTTING HEAD	1.50.1915
TS 500	STONE CUTTING HEAD	1.50.106
TW19	CUTTING HEAD	1.50.118
TF32	CUTTING HEAD	1.50.064
TR40	CUTTING HEAD	1.50.061
RD26	NUT-CRACKING HEAD	1.50.115
D180	SPREADING HEAD	1.50.112

**INDEX**

**0 DESCRIPTION OF THE MACHINE ..... 5**  
 0.01 MACHINE COMPONENTS ..... 5  
 0.02 SAFETY AND DANGER STICKERS - CE PLATE ..... 6  
 0.03 LIST OF ACCESSORIES INCLUDED IN THE SUPPLY ..... 6

**1 TECHNICAL FEATURES ..... 7**  
 1.01 HYDRAULIC, MECHANICAL AND ELECTRICAL SPECIFICATIONS ..... 7

**2 DELIVERY, COMMISSIONING AND SET-UP ..... 8**  
 2.01 DELIVERY ..... 8  
 2.02 ELECTRIC MOTOR ..... 8  
     2.02.01 ELECTRICAL CONNECTIONS ..... 8  
     2.02.02 COMMISSIONING ..... 8  
 2.03 MANUAL RETURN LEVER ..... 9  
 2.04 MOUNTING THE TOOL HEADS ..... 9  
 2.05 EQUIPMENT OPERATION ..... 10  
     2.05.01 STARTING ..... 10  
 2.06 FORESEEN USE AND RESIDUAL RISKS ..... 10

**3 ROUTINE MAINTENANCE ..... 12**  
 3.01 CHANGING AND TOPPING UP THE OIL ..... 12  
 3.02 CHECKING SCREWS ..... 14  
 3.03 HYDRAULIC COMPONENTS ..... 14  
     3.03.01 MANUAL RETURN VALVE DOES NOT CLOSE ..... 14  
     3.03.02 MAX. PRESSURE VALVE INCORRECTLY ADJUSTED ..... 14  
     3.03.03 MAIN CHECKS ON THE MOTOR ..... 14

**4 POTENTIAL PROBLEMS AND MEASURES TO BE ADOPTED ..... 15**  
 4.01 GENERAL ..... 15  
 4.02 TROUBLESHOOTING THE MOTOR ..... 15  
 4.03 TROUBLESHOOTING THE HYDRAULIC COMPONENTS ..... 16

**5 STORAGE AND RESTARTING ..... 17**  
 5.01 STORAGE ..... 17  
     5.01.01 ELECTRIC MOTOR ..... 17  
     5.01.02 CYLINDER AND HYDRAULIC COMPONENTS ..... 17  
 5.02 RESTARTING ..... 17

**6 MACHINE DISPOSAL ..... 18**

A brief legend indicating the most important symbols used in this manual is shown below.



***THIS SYMBOL WARNS USERS TO PAY SPECIAL ATTENTION WHEN FOLLOWING THE RELATIVE INSTRUCTIONS. FAILURE TO OBSERVE THESE INSTRUCTIONS CAN CAUSE THE MACHINE TO OPERATE INCORRECTLY.***



***THIS SYMBOL INDICATES POSSIBLE HAZARDS, TAKE ALL PRECAUTIONS TO PREVENT THESE SITUATIONS FROM OCCURRING.***



***BEFORE WORKING ON THE MACHINE, CAREFULLY READ ALL THE INSTRUCTIONS, ESPECIALLY THOSE CONTAINED IN BOXES.***

- “OPERATOR”:** A person suitably trained and authorised to operate, adjust, clean and transport the machine.
- “MAINTENANCE MAN”:** A person trained and authorised to perform routine maintenance on the machine and replace certain components.
- “MACHINE BODY”:** The equipment described in this manual.
- “ELECTRIC TOOL”:** Used in the safety precautions, it is a more general definition of the machine in question as it refers to mains-powered electric tools (with cable) or battery-powered electric tools (cordless).

## 0 DESCRIPTION OF THE MACHINE



**CAUTION!! FIRST READ THE MANUAL REGARDING THE GENERAL AND SAFETY REGULATIONS!**

### 0.01 MACHINE COMPONENTS

This machine is fitted with a single-phase alternating current motor.

The equipment comprises:

- a motor,
- a hydraulic pump driven by the motor,
- a rod actuator (piston) driven by the oil pressured by the pump,
- an interchangeable head with tool (purchased separately).

Figure 1 shows the main parts of the equipment, in particular:

1. cylinder with hydraulic components
2. head supporting surface and centring guides
3. release lever or double-acting lever
4. grip with start button
5. electrical connecting cable complete with plug
6. electric motor
7. oil cap
8. head locking ring

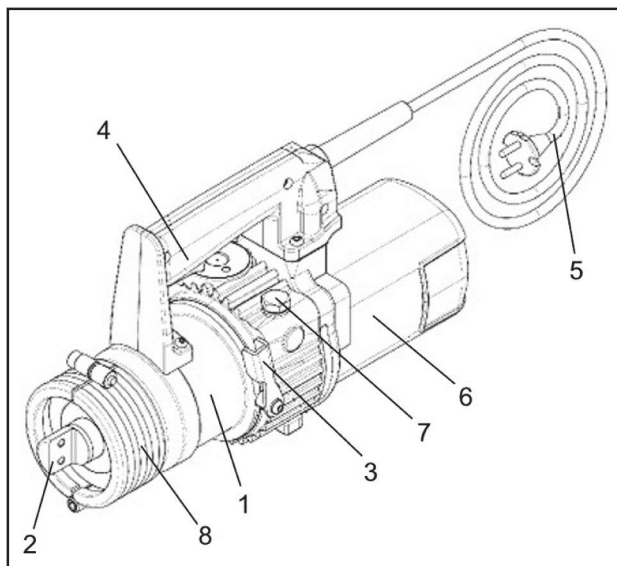

0.02 SAFETY AND DANGER STICKERS - CE PLATE

Position of plate and safety and danger stickers on the machine:

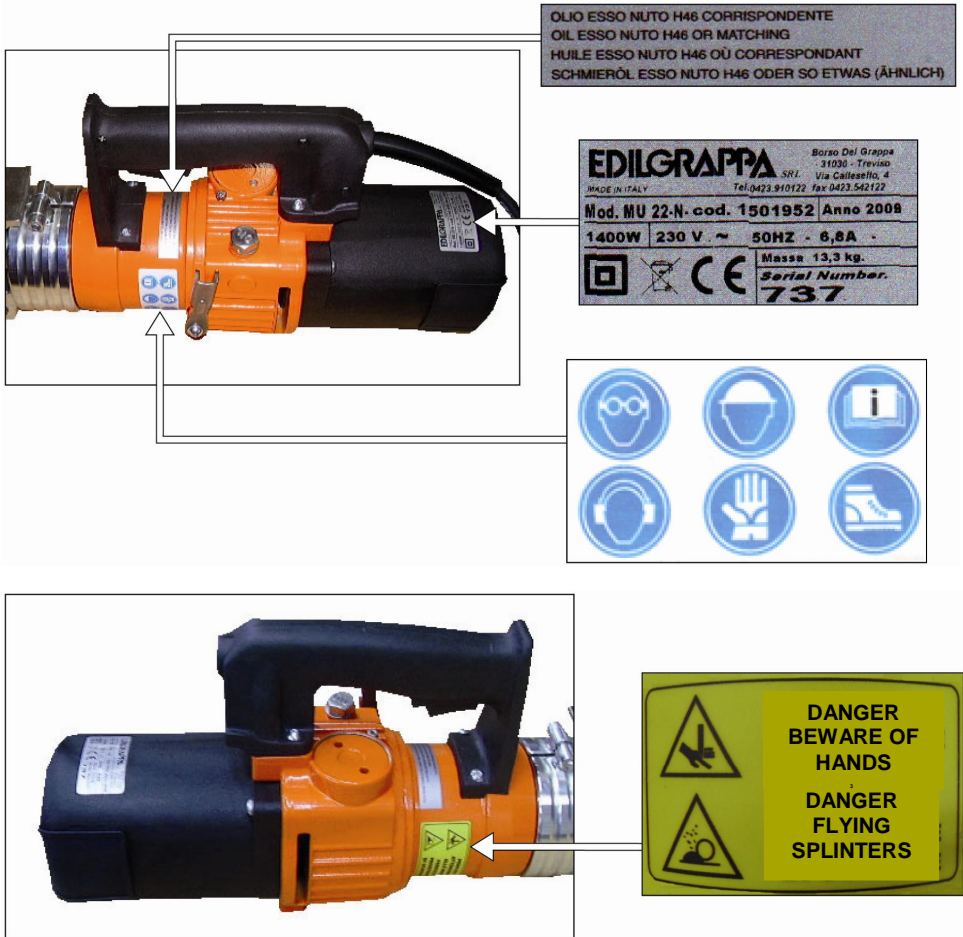

*Observe the warnings on the plates and stickers. Failure to do so could lead to injury or death. Make sure the plates and stickers are attached and legible. If not, apply them or request the maker for replacements.*

0.03 LIST OF ACCESSORIES INCLUDED IN THE SUPPLY

- Case
- General safety rules, Use and maintenance instructions
- Declaration of conformity
- Warranty certificate
- Emergency key

# 1 TECHNICAL FEATURES

## 1.01 HYDRAULIC, MECHANICAL AND ELECTRICAL SPECIFICATIONS

Maximum cutting size and characteristics of material [ mm and daN/mm <sup>2</sup> ]	Ø22 mm / R=65 daN/mm <sup>2</sup>
Maximum output force from rod [ t ]	24
Maximum operating pressure [ bar ]	580
Dimensions: Length X Width X Height [ mm ]	402 X 145 X 236
Weight [ kg ]	13.3
Guaranteed no-load LwA sound level (CEI EN 60745-1 and CEI EN 60745-2-8) [ dB ]	101
No-load operator Lpa (CEI EN 60745-1 and CEI EN 60745-2-8) [ dB ]	90
Vibrations when cutting diam. 22 mm rod (CEI EN 60745-1 and EN ISO 5349)	2.12 m/s <sup>2</sup>
Input voltage [ V ]	230
Frequency [ Hz ]	50
Electrical power [ W ]	1400
Input current [A]	6.8
Insulation class	II
RPM	14000

## 2 DELIVERY, COMMISSIONING AND SET-UP

### 2.01 DELIVERY

The machine is normally shipped and delivered inside a special hard case, well secured and in a stable position (see adjacent figure). All the ordered material is inspected before delivery to the customer.



***Upon receipt, check the machine for any damage (breakages or major denting) caused during transport. If so, immediately inform the shipping company and write the "Accepted subject to checking" clause on the Delivery note.***



***In the event of damage, send a written complaint to the forwarder within 8 days of receipt.***

***Promptly inform Edilgrappa s.r.l. if major damage, caused during transport, is found upon receipt, or if any parts are missing.***



***Also check the delivered materials against the detailed shipping list.***



The machine can be moved easily both when it is inside its special rigid case, using the upper handle, and by gripping its upper or lower handle.

***Loads must be moved in compliance with current occupational safety regulations.***

After use, put the machine back into its case or place it on a stable surface, making sure this can withstand its weight.

### 2.02 ELECTRIC MOTOR

#### 2.02.01 ELECTRICAL CONNECTIONS



***THE USER SYSTEM AND THE RESPECTIVE CONNECTIONS MUST BE MADE IN STRICT OBSERVANCE OF THE REGULATIONS IN FORCE, BY COMPETENT PERSONNEL QUALIFIED TO DO THE JOB.***



***BEFORE CONNECTING THE APPLIANCE USING THE PLUG SOCKETS, TURN THE MAIN SWITCH TO ITS OPEN POSITION "O".***

#### 2.02.02 COMMISSIONING



These machines do not need any adjustment or particular precautions before commissioning.

The only controls to perform concern:

- Machine integrity:  
make sure that nothing happened during transport that could damage the insulation or mechanical parts.
- Completeness of supply:  
check that all the supplied accessories are fitted.
- Oil level:  
check the oil level and top up if necessary as per the instructions in Para 3.01.



**IMPORTANT:** Before loosening the oil cap carefully read the instructions in Para 3.01.

### 2.03 MANUAL RETURN LEVER

The manual return lever has two positions (see fig. 2)

- Position 1: valve closed. The piston work and return stroke takes place automatically.
- Position 2: valve open. To interrupt the work stroke or in case of emergency move the lever to position 2 to return the piston to its home position.

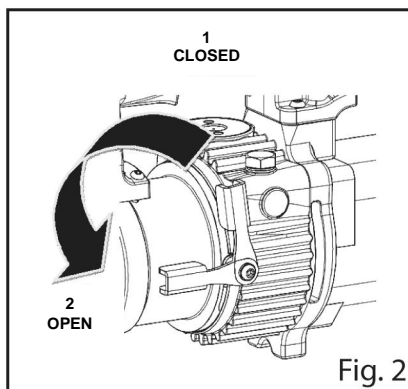

**IMPORTANT:** If the machine does not work make sure the manual return lever is in position 1.

### 2.04 MOUNTING THE TOOL HEADS



**IMPORTANT:** Before mounting any head on the machine body, carefully clean the piston rod (n° 1, 2, 3, 4, 5 in the following figure), the supporting surfaces and the centring guides.

To mount the head, follow the instructions in the “Commissioning” section of the Use and Maintenance Instructions relative to the specific head.

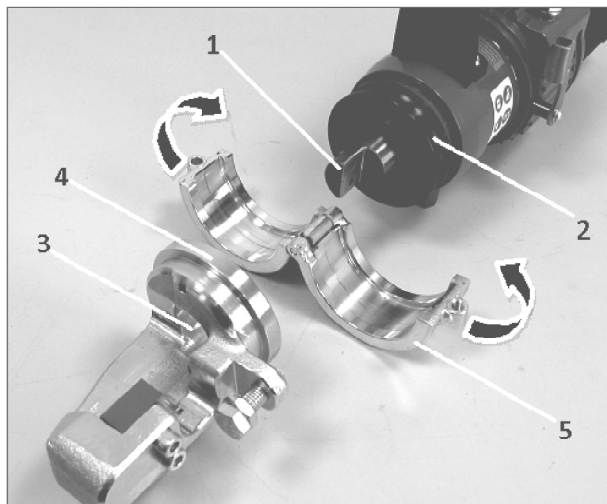

---

## 2.05 EQUIPMENT OPERATION

### 2.05.01 STARTING

Insert the plug in a suitable power socket and follow the instructions below, depending on the kind of machine involved.

### 2.05.02 OPERATING PHASE

The operating phase is strictly connected to the type of head applied to the machine body. Follow the instructions in the “Operating” section of the Use and Maintenance Instructions relative to the specific head.



**IMPORTANT:** Before starting work, scrupulously follow the general precautions for use and carefully consider the conditions of use bearing in mind the technical specifications.

---

## 2.06 FORESEEN USE AND RESIDUAL RISKS



**Follow the indications concerning foreseen use and residual risks contained in the use and maintenance manual of the work head attached to the machine.**

The machine must only be used with heads that are compatible with the machine body in question, as indicated on page 2 of this manual. The heads must be EDILGRAPPA s.r.l. and purchased from an authorised dealer. The machine has been designed and developed to operate in fields, such as building and industry, and for emergency/rescue operations.

The machine may only be used if powered by an electrical system compliant with legislation and current law (suitably connected to an earth system and protected from current surges and short circuits).

Any use other than that expressly indicated shall be considered as improper and therefore not permitted.

Edilgrappa S.r.l. declines all liability for any improper use of the machine and for any modification or change made to it.

Operators must observe the instructions in this manual and in the manual of the head fitted to the machine in order to minimise the risk of accidents. In particular, they must pay attention when working in conditions that could cause:

- Possible burns from overheated metal parts;
- Injury due to incorrect positioning or inadequate lifting or moving
- Injury caused by splinters discharged from the work piece.

People remaining in the vicinities of the machine while it is working are subject to the following risks:

- flying debris (dangerous objects, etc...);

Operating temperature	-40° ÷ +50° C
-----------------------	---------------



- ***It is strictly forbidden to use the machine for purposes other than those indicated in this installation and maintenance manual.***
- ***It is forbidden to use the machine in areas subject to the risk of explosion.***

### 3 ROUTINE MAINTENANCE



**1. All maintenance, inspection and cleaning operations must be performed with the power supply disconnected and the machine cool (see the person responsible in the maintenance schedule);**



- 2. Maintenance operations must be performed in a suitable place according to current safety regulations;**
- 3. Before any maintenance intervention, thoroughly clean the machine (see Paragraph 5.01);**
- 4. Wear suitable personal protective equipment while performing maintenance work.**



**AFTER MAINTENANCE WORK, MAKE SURE THE GUARDS ARE PUT BACK INTO THEIR CORRECT PLACE.**

#### Periodic maintenance schedule

Frequency	Operation	Method	Person
EVERY 8 HOURS	• CHECK THE INTEGRITY OF THE MACHINE	Visual	Operator
/	• CLEAN THE PISTON	Para 3.04.01	Operator
EVERY 1600 HOURS	• CHANGE THE OIL	Para 3.01	Maintenance man
EVERY 8 HOURS	• CHECK THE TIGHTNESS OF NUTS AND BOLTS	Para 3.02	Operator



**If you have any doubts about ordering spare parts or performing complex maintenance work, contact your authorised dealer.**

#### 3.01 CHANGING AND TOPPING UP THE OIL

When changing or topping up the oil, make sure no impurities contaminate the oil or enter the tank. Impurities in the oil can irreparably damage the hydraulic components.



**ALWAYS MAKE SURE THE OIL CONTAINS NO IMPURITIES  
DO NOT USE DIRTY TOOLS  
DO NOT WORK IN DUSTY AREAS**

#### **CHANGING THE OIL:**



**USING A SUITABLE DISPENSER, PREPARE THE CORRECT QUANTITY OF OIL (0.6 l) TO POUR INTO THE TANK.  
LEAKING OIL CAN CAUSE SHORT CIRCUITS, FIRE AND EXPLOSIONS.**

1. Place the machine horizontally in a stable position on a work surface with the magnetic cap (fig. 3) facing upwards. Place a basin under the machine to catch any oil leaks;
2. Unscrew the magnetic cap (fig. 4) and remove any residues with the piston in its retracted position;

3. Totally drain the oil tank using a suitable extraction system (used oil extraction pump) so that no oil can leak into the machine;
4. Loosen the vent screw (fig. 5);
5. Slowly pour in the correct quantity of oil (0.6 l) using suitable equipment (e.g. as shown in fig. 6). Only use new or clean recommended oil (as indicated on the next page);
6. Fill up to the upper rim of the hole;
7. Put back the oil cap and the vent screw and tighten slightly;
8. Perform some piston strokes to vent the large air bubbles;
9. Move the piston to its maximum extension and rapidly start and stop the motor several times (before the piston automatically retracts);
10. Complete filling;
11. Put back the oil cap and vent screw and tighten (figs. 4 and 5).

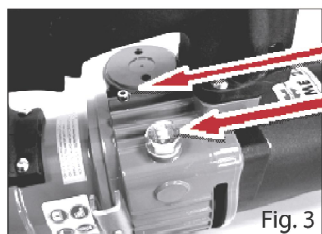

VENT SCREW  
MAGNETIC CAP

Fig. 3

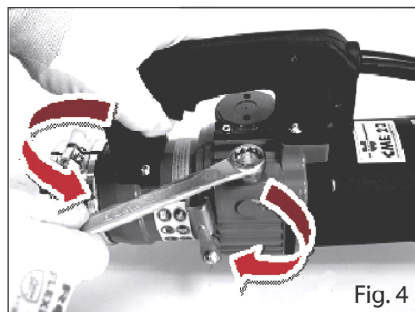

Fig. 4

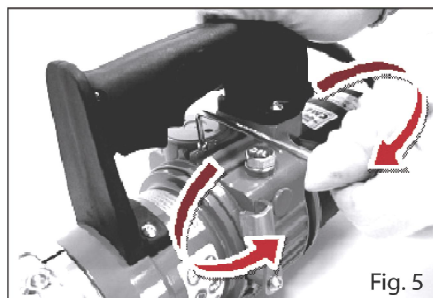

Fig. 5



Fig. 6

### TOPPING UP THE OIL:



***Before unscrewing the magnetic cap to check the oil level, make sure the piston is fully extended and, if necessary, pull it out. If this is not done the oil may leak, air bubbles may form and/or the oil level may be incorrectly measured, thus causing the machine to operate incorrectly.***

Only after completing the above operations, proceed as shown below:

1. Place the machine horizontally in a stable position on a work surface with the filling hole facing upwards. Place a basin under the machine to catch any oil leaks;
2. Move the piston to its maximum extension and rapidly start and stop the motor several times (before the piston automatically retracts);
3. Unscrew the magnetic cap (see fig. 4) and remove any residues;
4. Check the amount of missing oil;
5. Loosen the vent screw (fig. 5) and slowly top up to the upper rim of the hole with recommended new and clean oil using suitable equipment (e.g.: as indicated in fig. 6);
6. Put back the oil cap and vent screw and tighten (figs. 4 and 5).

Maximum quantity: 0.6 l.  
Type of hydraulic oil: ESSO NUTO H46 or  
homologated equivalents HLP46  
according to DIN 51 524 MIL-H 17672 C



***When demolishing the machine or parts of it (oil, plastic, etc.) observe the regulations in force in the country in which this operation is performed.***

### 3.02 CHECKING SCREWS

---

Periodically, or every day in the event of frequent or prolonged work, make sure that all the screws are perfectly tight.



***FAILURE TO TIGHTEN LOCKING SCREWS CAN CAUSE SERIOUS DAMAGE.***

### 3.03 HYDRAULIC COMPONENTS

---

#### ***3.03.01 MANUAL RETURN VALVE DOES NOT CLOSE***

If the piston is unable to perform another stroke make sure the manual return lever is closed.

#### ***3.03.02 MAX. PRESSURE VALVE INCORRECTLY ADJUSTED***

In case of a pressure drop for a reason that cannot be directly identified, have a maintenance man or the maker check the maximum pressure valve is clean and calibrated.

#### ***3.03.03 MAIN CHECKS ON THE MOTOR***

- Keep the motor surfaces clean, especially the fins on the head
- Keep the motor cooling slits clean and unobstructed
- Check the brushes for wear: replace them with authentic spare parts when their length is less than 5mm.

## 4 POTENTIAL PROBLEMS AND MEASURES TO BE ADOPTED

### 4.01 GENERAL

Faults can be divided into three sections:

1. faults on the motor
2. faults on the head
3. faults not closely connected with the machine



**ALL OPERATIONS MUST BE PERFORMED BY QUALIFIED PEOPLE IN OBSERVANCE OF SAFETY REGULATIONS.**



**WORK ON THE MACHINE DURING THE WARRANTY PERIOD MUST BE PERFORMED AT THE MAKER'S FACILITY**



**Remedies marked with the letter R require the assistance of the Authorised dealer. The remedies marked by the letter M require the intervention of the Manufacturer. Remedies marked with the letter O can be performed by the Operator.**

### 4.02 TROUBLESHOOTING THE MOTOR

FAULT	POSSIBLE REASON	POSSIBLE REMEDY	PERFORMED BY
MOTOR DOES NOT START	Broken power cable	Replace cable with one having the same specifications	M
	Faulty plug	Replace	M
	Stator windings	Replace	R
	Rotor windings	Replace	R
	Switch	Replace	R
	No electric power	Check the line and the cable protections	M
ELECTRIC MOTOR OVERHEATED	Worn brushes	Replace	R
	Worn manifold	Replace or overhaul	R
	Insufficient power supply	Check the line, the protections of the electric panel and the tightness of the connection terminals	M
	Partial fault of the stator windings	Replace	R
	Partial fault of the rotor windings	Replace	R
	Windings dirty	Clean	M
	Ventilation slits obstructed	Clean	O
	Fan broken	Replace	R
	Motor supports worn	Replace	R
Mechanical faults on the head	Overhaul	R	

FAULT	POSSIBLE REASON	POSSIBLE REMEDY	PERFORMED BY
ELECTROMAGNETIC DISTURBANCES IN LINE	Fault in anti-disturbance filter	Replace	R
	Manifold worn	Replace	R
	Brushes worn	Replace	R

**4.03 TROUBLESHOOTING THE HYDRAULIC COMPONENTS**

FAULT	POSSIBLE REASON	POSSIBLE REMEDY	PERFORMED BY
OUTWARD STROKE DOES NOT BEGIN	Return stroke incomplete	Push back the piston	O
	Return spring broken (if present)	Replace	O
	Max. pressure valve dirty	Consult the Maker	/
	Manual return valve dirty	Clean	O
	Manual return valve faulty	Repair	M
	Oil tank empty	Fill	O
	Valve remains open due to built-up dirt	Clean	O
MOTOR DOES NOT STOP	Earth cable interrupted	Repair	M
	Earth cable rusted	Clean	O
OUTWARD STROKE INCOMPLETE	No oil	Top up	O
OUTWARD STROKE DISCONTINUOUS	Air bubbles in the hydraulic circuit	Vent	O
	Max. pressure valve open due to built-up dirt	Consult the Maker	/
	Pump faulty or dirty	Replace	M
	Piston gasket faulty	Replace	M
	Pump O-ring	Replace	M
RETURN STROKE INCOMPLETE	Dirt between piston rod and tool	Move the piston to its end-of-stroke position and clean	O
	Return spring broken	Replace	O
NO FORCE	Oil hydraulic pump faulty	Replace	M
	Dirt on oil hydraulic pump valve	Replace	M
	Max. pressure valve open	Replace	M
	Piston gasket worn	Replace	M
	Pump O-ring broken	Replace	M
PISTON DOES NOT AUTOMATICALLY REVERSE STROKE	Automatic reverse valve faulty	Replace	M
OIL LEAKS FROM TANK COVER	Membrane faulty	Replace	O



## 5 STORAGE AND RESTARTING

### 5.01 STORAGE

In case of long periods of inactivity, proceed as follows:

#### 5.01.01 ELECTRIC MOTOR

- Clean all the internal electrical parts (rotor, stator, cooling circuit) with compressed air



**DO NOT USE CONDUCTIVE OR FLAMMABLE LIQUIDS TO CLEAN INTERNAL ELECTRICAL PARTS**

- To clean the outside of the machine, if necessary, use a cloth dampened in soapy water and then dry thoroughly
- Check the following are in good condition:
  - insulation
  - power cable
  - switches
  - plug
  - brushes and manifold
  - clean the stator, rotor, cooling circuit and fan with compressed air

#### 5.01.02 CYLINDER AND HYDRAULIC COMPONENTS

Before performing these operations, see the relative instructions in Chap. 3

- Check the hydraulic oil and top up or, if necessary, replace.
- Clean the magnetic cap and check the membrane.
- Check for any oil leaks.
- Tighten the screws.

Store the tool in a dry place that can only be accessed by authorised staff.

### 5.02 RESTARTING

Before performing these operations, see the relative instructions in Chap. 3

- Check the oil tank is full and top up if necessary
- Remove any traces of oil remaining after topping up or applied to protect metal parts from the grip and other parts that can be gripped.

#### ELECTRIC MOTOR

- Ensure that the power cable, the plug and the machine body have not been damaged.
- Start the machine a few times and make sure no operating faults occur.



**ELIMINATE ANY FAULTS BEFORE STARTING WORK.**

## 6 MACHINE DISPOSAL

When disposing of the machine, the various materials must be separated.

The machine comprises the following groups of materials:

- ferrous materials
- copper
- plastic

Observe current legislation when sorting, storing, recycling or disposing of these materials.

Only for EU countries:



This electric tool features the following recycling symbol. Consistently with Directive 2002/96/EC on waste electrical and electronic equipment (WEEE), at the end of its useful lifetime, this product must be disposed of separately in suitable collection areas and not together with normal domestic waste. A benefit for the environment and an advantage for all.

**EDILGRAPPA**

**S.r.l.**

**Building, industrial and rescue machines and equipment.**

Via Callesello, 4 – 31030 BORSO DEL GRAPPA (TV)

Tel. (+39) 0423 910122 r.a. – Fax (+39) 0423 542122

[cut@edilgrappa.com](mailto:cut@edilgrappa.com)

[www.edilgrappa.com](http://www.edilgrappa.com)

**DECLARATION  
OF CONFORMITY**



**Maker:**

**EDILGRAPPA srl**  
**Machines and equipment for the building trade, industry and rescue**

Via Callesello, 4  
31030 Borso Del Grappa (TV)

**Name and address of person authorised to draw up the technical brief:**

Giacomo Rorato  
Via Callesello, 4  
31030 Borso Del Grappa (TV)

**Generic name:**

Portable electric power tool (cordless)

**Function:**

cutting metal rod Ø max 22 mm

**Type:**

Electric shear

**Model:**

**MU 22N**

**Commercial name:**

**MU22N machine body with interchangeable heads**

**Serial number:**

\_\_\_\_\_

**Year of construction:**

\_\_\_\_\_

DECLARES THAT THE ABOVE-MENTIONED EQUIPMENT IS COMPLIANT WITH THE FOLLOWING DIRECTIVES:

Machinery Directive	2006/42/EC (Proc. App. VIII)
EMC Directive	2004/108/EC
Low Voltage Directive	2006/95/EC
RoHS Directive	2011/65/EC
WEEE Directive	2002/96/EC

Place: Borso Del Grappa TV

Date.....

Signature

PAOLO MAZZARO  
(legal representative)



Product Certified by ISET S.r.l. Notified body n° 0865:

**EDILGRAPPA** Srl  
**MACHINES AND EQUIPMENT FOR THE BUILDING TRADE,  
INDUSTRY AND RESCUE**

31030 BORSO DEL GRAPPA (TV) - ITALY - Via Callesello, 4  
Tel. 0423 910122 – Fax 0423 542122

E-mail: [cut@edilgrappa.com](mailto:cut@edilgrappa.com) <http://www.edilgrappa.com>