

Spare Parts List

SALVADOR

PROLINE

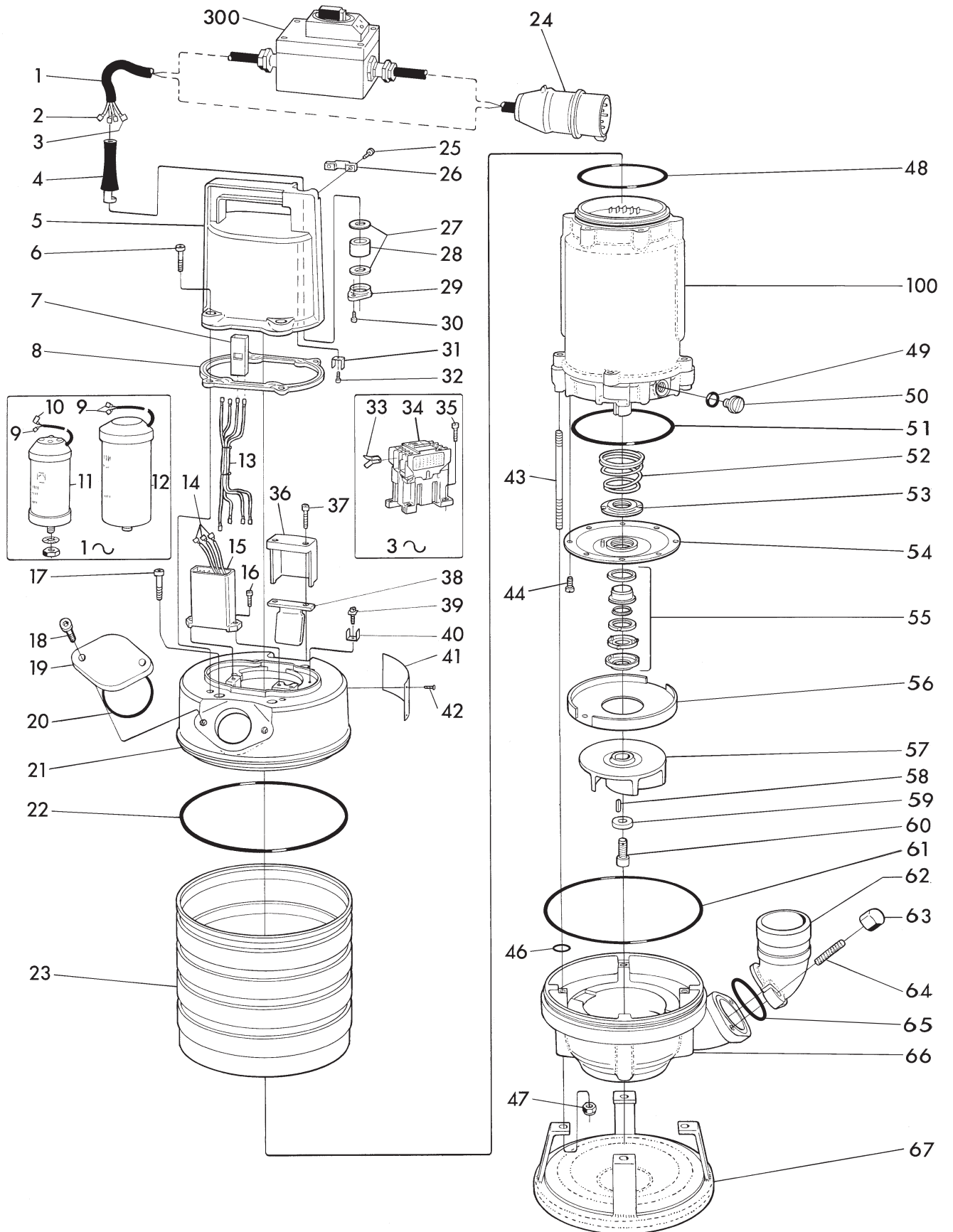

Motorenhet	Motor unit	Motoreinheit	Moteur complet
------------	------------	--------------	----------------

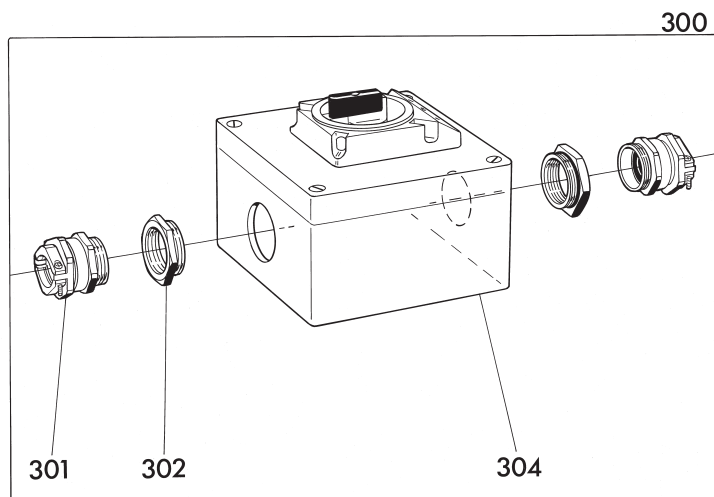
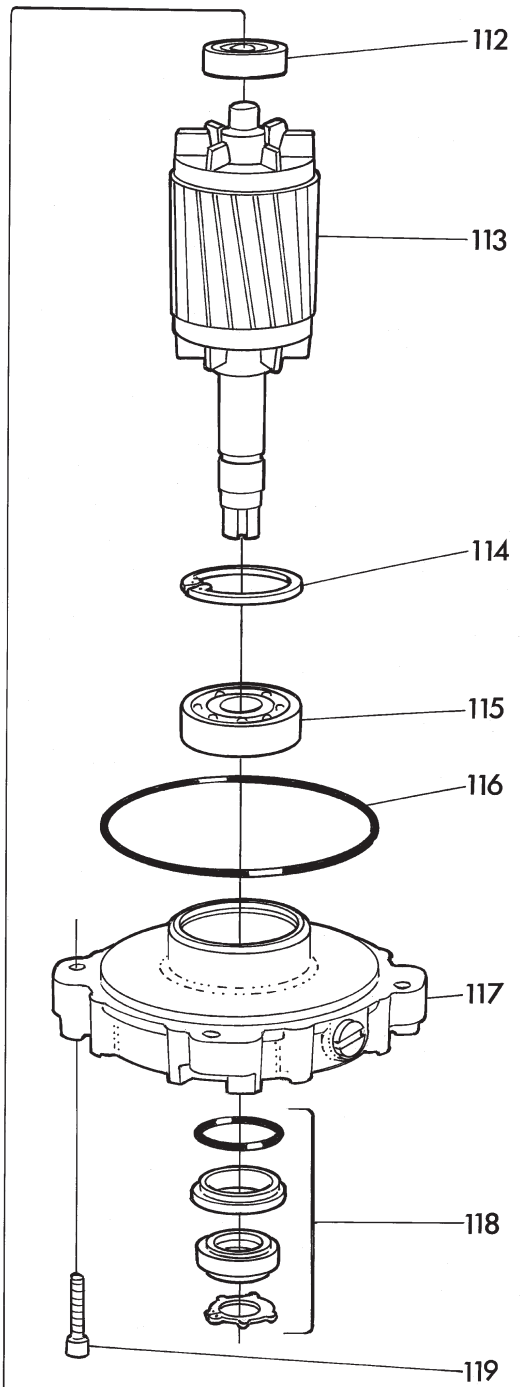
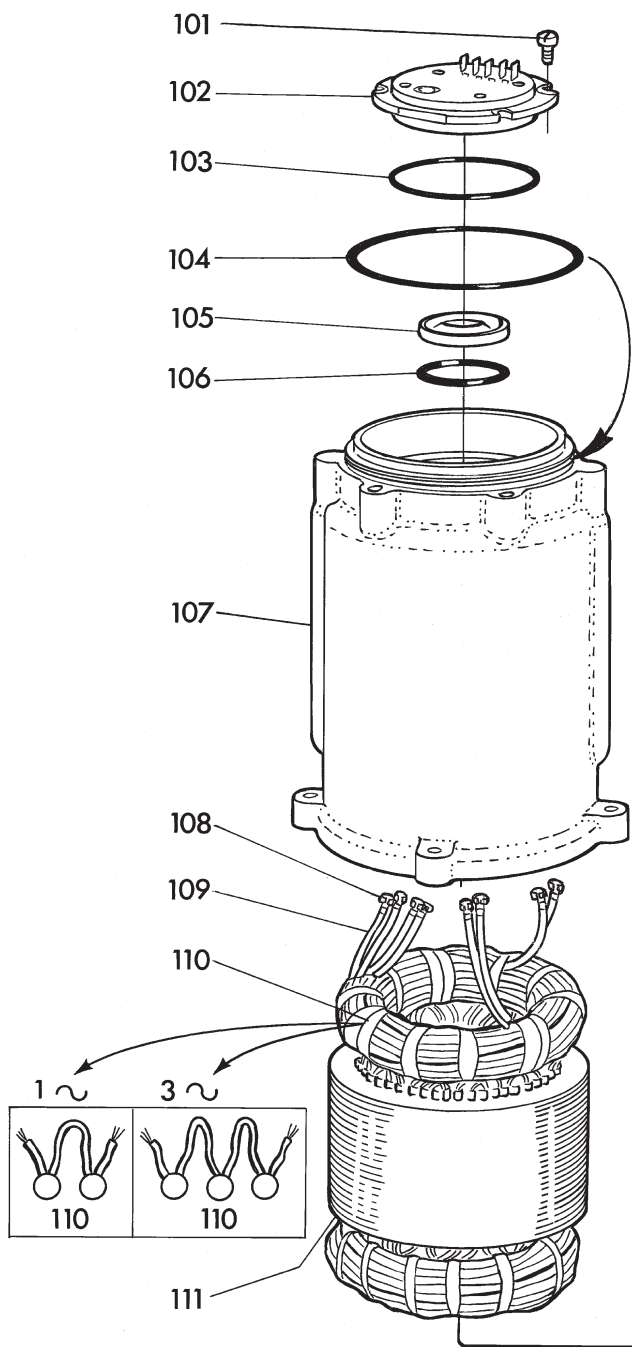

Reservdelista	Spare Parts List	Ersatzteilliste	Liste des pièces de rechange
Salvador Type G70xx		Salvador Type G71xx	
1= 1-fas 1-phase W Monophasé		3= 3-fas 3-phase D Triphasé	

RF	ST	VJ	FZ
Rostfritt stål	Stål	Vitjäm	Förzinkad
Stainless steel	Steel	White iron	Galvanized
Rostfreier Stahl	Stahl	Chromlegierter Hartguss	Galvanisiert
Acier inoxydable	Acier	Fonte blanche alliée au chrom	Galvanisé

Pos. nr.						Antal
Item No.	Detail nr.				Quantity	
Pos.-Nr.	Part No.				Anzahl	
No. de	Bestell-Nr.				Nombre	

repérage	No de pièce	Benämning	Denomination	Bezeichnung	Désignation	1	3
1		Kabel inkl pos 2, 3, 4	Cable incl items 2, 3, 4	Kabel einsch. Pos. 2, 3, 4	Câble avec No. de rep 2, 3, 4		
	50 142 07	3x2,5mm ² (H07RN-F Ø10,9-14) 20m	220-240V			1	-
	50 143 09	4x1,5mm ² (H07RN-F Ø10,2-13,1) 20m	220-575V			-	1
		Gäller upp till 20m längd. Vid annan längd kontakta Grindex.	Refers to length of 20m. For other lengths please contact Grindex.	Bezieht sich auf Länge von 20 Metern. Für andere Längen bitte fragen Sie Grindex.	Concernant longueur de 20 metres. Pour autres longueurs consultez Grindex.		
2	50 040 03	Flatstiftshylsa	Receptacle	Steckhülse	Clip	2	4
3	50 040 00	Flatstiftshylsa 90°	Receptacle 90°	Steckhülse 90°	Clip 90°	1	-
4		Kabelböjskydd	Cable entry sleeve	Hülse für Kabeleinführung	Douille d'entrée de câble		
	50 428 00	För Ø9,5-12mm	For Ø9,5-12mm	Für Ø9,5-12mm	Pour Ø9,5-12mm	1	1
	50 428 01	För Ø12-13,8mm	For Ø12-13,8mm	Für Ø12-13,8mm	Pour Ø12-13,8mm	(1	1)
5	50 001 04	Lock	Cover	Deckel	Couvercle	1	1
6	50 021 00	Skruv M8x25	Screw	Schraube	Vis	4	4
7	50 086 00	Skarvhylsa	Flat lug connector	Steckverbindung	Connexion plat	2	-
8	50 038 00	Planpackning	Gasket	Dichtung	Garniture	1	1
9	50 040 03	Flatstiftshylsa	Receptacle	Steckhülse	Clip	3	-
10	50 040 00	Flatstiftshylsa 90°	Receptacle 90°	Steckhülse 90°	Clip 90°	1	-
11	50 059 01	Startkondens. 80µF	Start capacitor	Startkondensator	Condensateur de dém.	1	-
12	50 036 02	Driftkondens. 30µF	Run capacitor	Betriebskondensator	Condensateur de marche	1	-
13	50 035 00	Kabelhärva	Conductors, set	Leitungen, Satz	Conducteurs, compl.	1	-
13	50 035 01	Kabelhärva	Conductors, set	Leitungen, Satz	Conducteurs, compl.	-	1
14	50 203 00	Gaffelkabelsko	Spade terminal	Gabelkabelschuhe	Cosse	-	4
15	50 033 00	Startrelä med motorskydd	Start relay with motor protector	Startrelais mit Motorschutz	Relais de démarrage avec disjoncteur	1	-
15		Motorskydd	Motor protector	Motorschutzschalter	Disjoncteur disjoncteur	-	1
	50 Hz		60 Hz				
	50 034 00	190-240V	50 034 03	190-240V			
	50 034 01	340-460V	50 034 04	340-460V			
	50 034 02	500-575V	50 034 05	500-575V			
16	50 018 00	Skruv M4x12	Screw	Schraube	Vis	2	2
17	50 021 00	Skruv M8x25	Screw	Schraube	Vis	4	4
18	50 021 20	Skruv M10x25	Screw	Schraube	Vis	2	2
19	132 657	Inspektionslock	Inspection cover	Deckel	Couvercle	1	1
20	140 366	O-ring 56x5.34	O-ring	O-Ring	Anneau torique	1	1
21	50 007 00	Överdel	Main cover	Hauptdeckel	Couvercle principal	1	1

Item No.	Part No.	Benämning	Denomination	Bezeichnung	Désignation	1	3
22	140 367	O-ring 219.5 x 3.2	O-ring	O-Ring	Anneau torique	1	1
23	50 063 01	Mantel	Outer casing	Aussenmantel	Enveloppe extérieure	1	1
24		Europahandske	Euro plug	Euro-Verdinder	Euro connecteur		
	140 106	Stickpropp 230V/50HZ	Single phase plug	Einphasenstecker		(1)	-
	50 100 00	CEE 416-6 (380-400V/50Hz)				-	(1)
	50 100 10	CEE 316-7 (500V/50Hz)				-	(1)
25	50 019 00	Skruv M5x18	Screw	Schraube	Vis	2	2
26	50 011 00	Kabelavlastning	Cable clamp	Zugentlastung	Collier	1	1
27		Tätningbricka för kabel:	Washer, for cable:	Scheibe, für Kabel:	Rondelle, pour câble:	2	2
	50 016 00	Ø8-12mm (Ø0.31-0.47in)					
	50 016 01	Ø12-14mm (Ø0.47-0.55in)					
28		Gummikuts	Rubber seal	Gummidichtung	Manchon, pour câble:	1	1
	50 015 10	Ø8-10mm (Ø0.31-0,40in)					
	50 015 00	Ø10-12mm (Ø0.40-0.47in)					
	50 015 01	Ø12-14mm (Ø0.47-0.55in)					
29	50 017 01	Införingsfläns	Cable entry flange	Kabeleinführungsflansch	Bride d'entrée de câble	1	1
30	50 019 00	Skruv M5x18	Screw	Schraube	Vis	2	2
31	50 119 00	Flatstiftsbleck	Tab	Flachstecker	Ian guette	1	1
32	50 018 01	Skruv M4x8	Screw	Schraube	Vis	1	1
33	50 120 01	Flatstiftsbleck	Tab	Flachstecker	Ian guette	-	3
34		Kontaktor	Contacteur	Kontaktor	Contacteur	-	1
	50 Hz		60 Hz				
	50 353 08	220V	50 353 12	230V			
	50 353 05	346V	50 353 05	380V			
	50 353 01	380-415V	50 353 06	460V			
	50 353 03	500-550V	50 353 03	575V			
35	50 018 00	Skruv M4x12	Screw	Schraube	Vis	-	4
36	50 012 00	Ventillock	Valve cover	Ventildeckel	Couvercle de soupape	1	1
37	50 019 00	Skruv M5x18	Screw	Schraube	Vis	2	2
38	50 013 00	Ventil	Valve	Ventil	Soupape	1	1
39	133 525	Skruv	Screw	Schraube	Vis	1	1
40	50 119 00	Flatstiftsbleck	Tab	Flachstecker	Ian guette	1	1
41	50 010 05	Dataskylt, ostämplad	Data plate, blank	Datenschild, ungepr.	Plaque signal. vide	1	1
42	50 139 00	Popnit	Rivet	Niet	Rivet	4	4
43	50 021 16	Pinnskruv M 8x137	Stud	Stiftschraube	Goujon	4	4
44	140 054	Skruv M6x16	Screw	Schraube	Vis	8	8
46	50 037 18	O-ring	O-ring	O-Ring	Anneau torique	4	4
47	140 361	Mutter M8	Nut	Mutter	Ecrou	4	4
48	140 071	O-ring 117.5x5.34	O-ring	O-Ring	Anneau torique	1	1
49	140 077	O-ring 12.37x2.62	O-ring	O-Ring	Anneau torique	1	1
50	140 034	Oljeskruv	Oil screw	Ölschraube	Vis d'huile	1	1
51	140 376	O-ring 134.5x3.0	O-ring	O-Ring	Anneau torique	1	1
52	50 559 00	Fjäder, grön	Spring, green	Feder, grün	Ressort, vert	1	1
53	50 573 00	Tryckplatta	Thrust plate	Druckscheibe	Rondelle	1	1
54	50 581 00	Oljehusbotten	Oil housing bottom	Ölgehäuseboden	Fond de carter à huile	1	1
55	50 420 00	Axeltätningssats, undre	Shaft seal kit, lower	Wellendichtung, unt.,Satz	Joint mécanique, inf. jeu	1	1
56	132 655	Styrplåt	Guide plate	Steuerblech	Plaque de recouvrement	1	1

Item No.	Part No.	Benämning	Denomination	Bezeichnung	Désignation	1	3
57		Pumphjul	Impeller	Lauftrad	Turbine		
		50Hz		60Hz			
	132 933	Ø120 mm VJ	132887	Ø105mm (4.12 in) VJ		1	-
	132 933RF	Ø120 mm RF	132887RF	Ø105mm (4.12 in) RF		1	-
	132 652	Ø120 mm VJ	132653	Ø109mm (4.29 in) VJ		-	1
	132 652RF	Ø120 mm RF	132653RF	Ø109mm (4.29 in) RF		-	1
			133092	Ø88mm (3,46in) Reduced diameter VJ		1	-
			133093	Ø91mm (3,58in) Reduced diameter VJ		-	1
			133093RF	Ø91mm (3,58in) Reduced diameter RF		-	1
58	50 205 03	Plattkil 5x5x14	Key 5x5x14	Keil 5x5x14	Clavette 5x5x14	1	1
59	133 147	Bricka	Washer	Scheibe	Rondelle	1	1
60	133 148	Skruv	Screw	Schraube	Vis	1	1
61	50 037 49	O-ring 216.0 x 3.0	O-ring	O-Ring	Anneau torique	1	1
62		Tryckanslutning	Discharge conn.	Druckanschluss	Coude de refoulement	1	1
	140 152	3"					
	130 890	R 3" W BSP					
	50 348 00	NPT 3-8 male					
63	140 089	Mutter M10	Nut	Mutter	Ecrou	2	2
64	130 731	Pinnskruv	Stud	Stiftschraube	Goujon	2	2
65	140 366	O-ring 56,52 x 5,34	O-ring	O-Ring	Anneau torique	1	1
66	50 065 00	Pumphus	Pump housing	Pumpengehäuse	Corps de pompe	1	1
67		Stödenhet	Stand	Ständer	Pied	1	1
	132 740	FZ					
	132 740RF	RF					
100		Motorenhet	Motor unit	Motoreinheit	Moteur complet		
101	140 494	Skruv M 8x10	Screw	Schraube	Vis	4	4
102	50 009 00	Kopplingsplint	Terminal board	Klemmenbrett	Plaque à bornes	1	1
103	130 623	O-ring 74.61x3.53	O-ring	O-Ring	Anneau torique	1	1
104	50 037 01	O-ring 119.5x3.0	O-ring	O-Ring	Anneau torique	1	1
105	140 365	Täckbricka	Protection cover	Schutzdeckel	Couvercle de protecteur	1	1
106	140 369	O-ring 39,69x3,53	O-ring	O-Ring	Anneau torique	1	1
107	50 081 02	Statorhus	Stator housing	Statorgehäuse	Logement de stator	1	1
108		Flatsstifthylsa/ serieskarv	Receptacle/ joining tube	Steckhülse / Verbindung	Clip/ connexion		
	50 040 03	Flatsstift	Solderless lug	Flachsteckkontakt	Pris contact plat	6	5-11
	50 182 00	Serieskarv 460V endast 9-ledare	Joining tube 460V only 9-leads	Verbindung 460V nur 9-Leiter	Connexion 460V 9-conducteurs seules.	-	3
109	50 079 00	Systoflexrör 40 mm	Insulating tube	Isolierschlauch	Gaine isolante	2	3
110		Termokontakt	Thermal contact	Thermokontakt	Contact thermique		
	50 039 00	1-fas	Single phase	Einphasig	Monophasé	1	-
	50 039 01	3-fas	Three phase	Dreiphasig	Triphasé	-	1
111		Stator	Stator	Stator	Stator	1	1
		50 Hz		60 Hz			
	50 042 02	220-240V 1-phase	50 042 12	230V 1-phase			
	50 042 04	200/346V	50 042 13	220/380V			
	50 042 05	220-230/380-415V	50 042 14	230/460V 9-leads			
	50 042 09	500-550V Y	50 042 16	575V Y			
112	140 362	Kullager, övre	Ball bearing, upper	Kugellager, oberes	Roulement à billes sup.	1	1
113	134 261	Rotorenhet	Rotor unit	Rotoreinheit	Rotor complet	1	1

Item No.	Part No.	Benämning	Denomination	Bezeichnung	Désignation	1	3
114	140 064	Låsring SgH 62	Circlip	Nutring	Circlip	1	1
115	140 363	Lager, undre	Ball bearing, lower	Kugellager, unteres	Roulement à billes inf.	1	1
116	140 377	O-ring 144,5x3.0	O-ring	O-Ring	Anneau torique	1	1
117	50 546 00	Lagerhållare	Bearing holder	Lagerhalter	Logement de roulement	1	1
118	50 534 00	Axeltätningssats, övre	Shaft seal kit, upper	Wellendichtung, ob.,Satz	Joint mécanique, sup. jeu	1	1
119	50 021 14	Skruv M8x35	Screw	Schraube	Vis	4	4
300		Fasväxlare 16A inkl. pos. 301	Phase shifter 16A incl. item 301	Phasenwechsler 16A einchl. Pos. 301	Inverseur de phase 16A avec No. 301		(1)
	50 102 20	Ø8-11mm					
	50 102 00	Ø11-14,5mm					
301	50 276 00	Kabelavtätning	Cable entry	Kabelverschraubung	Entrée de cable		2
	50 276 02	Ø8-11mm					
	133 841	Ø11-14,5mm					
	50 085 06	O-ringsats, bestående av:	Set of O-rings, comprising:	O-Ringsatz, bestehend aus:	Anneaux toriques, jeu comprenant:	1	1
8	50 038 00	(1)	51	140 376 (1)			
20	140 366	(2)	61	50 037 49 (1)			
22	140 367	(1)	103	130 623 (1)			
46	50 037 18	(4)	104	50 037 01 (1)			
48	140 071	(1)	106	140 369 (1)			
49	140 077	(1)	116	140 377 (1)			
	50 553 10	Skruskyddsats Olja	Screw cap kit Oil	Schraubenkappe satz Öl	Kit de chapeaux de vis Huile		0.30L
		Vitolja	White oil	Weißöl	Huile cristalline		
		Viskositet ISO VG 15	Viscosity ISO VG 15	Viskosität ISO VG 15	Viscosité ISO VG 15		

Specifications can be changed without notice.

Notes

GRINDEX

Grindex AB	Box 538	SE-136 25 Haninge	Sweden
Tel:+46 8 606 66 00		Fax:+46 8 745 16 06	
e-mail: grindex@grindex.com		www.grindex.com	