

Installation, Operation, and Maintenance Manual

8101.082/.171 Minex



Table of Contents

Introduction and Safety	3
Introduction.....	3
Safety terminology and symbols.....	3
Inspect the delivery.....	4
Inspect the package.....	4
Inspect the unit.....	4
Product warranty.....	4
Safety.....	5
User safety.....	5
Hazardous liquids.....	6
Wash the skin and eyes.....	6
MSHA requirements.....	6
Environmental safety.....	7
Transportation and Storage	9
Transportation guidelines.....	9
Precautions.....	9
Position and fastening.....	9
Lifting.....	9
Storage guidelines.....	9
Storage location.....	9
Freezing precautions.....	9
Long-term storage.....	10
Product Description	11
Products included.....	11
Pump design.....	11
Monitoring equipment.....	11
Level regulators.....	12
The data plate.....	13
The MSHA approval plate.....	14
Installation	15
Install the pump.....	15
Sedimentation prevention.....	15
Discharge line requirements.....	16
Fasteners.....	16
Install.....	16
Make the electrical connections.....	17
General precautions.....	17
Requirements.....	17
Cables.....	18
Earthing (Grounding).....	18
Earth (ground) conductor length.....	18
Product-specific precautions.....	18
Switch between higher and lower supply voltages.....	19
Connect the motor cable to the pump.....	19
Cable charts for connection with sealed terminal plate, standard version	19
Cable charts for connection without sealed terminal plate, standard version	23
Cable charts, MSHA version	25
Check the impeller rotation: Pumps without built-in motor protection	26
Check the phase sequence: Pumps with built-in motor protection.....	27

Operation	30
Precautions.....	30
Distance to wet areas.....	30
Noise level.....	30
Start the pump.....	30
Clean the pump.....	31
Maintenance	32
Precautions.....	32
Maintenance guidelines.....	32
Torque values.....	32
Service.....	33
Inspection.....	33
Major overhaul.....	35
Change the oil.....	35
Empty the oil.....	35
Fill with oil.....	36
Replace the impeller.....	36
Remove the impeller N, H	36
Install the impeller N, H	38
Troubleshooting	42
Introduction.....	42
The pump does not start, for pumps with SMART™	42
The pump does not start.....	43
The pump does not stop when a level sensor is used.....	44
The pump starts-stops-starts in rapid sequence.....	44
The pump runs but the motor protection trips.....	45
The pump delivers too little or no water.....	46
Technical Reference	48
Application limits.....	48
Motor data.....	48
Specific motor data, standard version	49
Specific motor data, MSHA version	50
Dimensions and weights.....	51
Performance curves.....	54

Introduction and Safety

Introduction

Purpose of this manual

The purpose of this manual is to provide necessary information for:

- Installation
- Operation
- Maintenance



CAUTION:

Read this manual carefully before installing and using the product. Improper use of the product can cause personal injury and damage to property, and may void the warranty.

NOTICE:

Save this manual for future reference, and keep it readily available at the location of the unit.



Safety terminology and symbols

About safety messages

It is extremely important that you read, understand, and follow the safety messages and regulations carefully before handling the product. They are published to help prevent these hazards:

- Personal accidents and health problems
- Damage to the product
- Product malfunction

Hazard levels

Hazard level	Indication
 DANGER:	A hazardous situation which, if not avoided, will result in death or serious injury
 WARNING:	A hazardous situation which, if not avoided, could result in death or serious injury
 CAUTION:	A hazardous situation which, if not avoided, could result in minor or moderate injury

Hazard level	Indication
NOTICE: 	<ul style="list-style-type: none"> • A potential situation which, if not avoided, could result in undesirable conditions • A practice not related to personal injury

Hazard categories

Hazard categories can either fall under hazard levels or let specific symbols replace the ordinary hazard level symbols.

Electrical hazards are indicated by the following specific symbol:



Electrical Hazard:

These are examples of other categories that can occur. They fall under the ordinary hazard levels and may use complementing symbols:

- Crush hazard
- Cutting hazard
- Arc flash hazard

Inspect the delivery

Inspect the package

1. Inspect the package for damaged or missing items upon delivery.
2. Note any damaged or missing items on the receipt and freight bill.
3. File a claim with the shipping company if anything is out of order.
If the product has been picked up at a distributor, make a claim directly to the distributor.

Inspect the unit

1. Remove packing materials from the product.
Dispose of all packing materials in accordance with local regulations.
2. Inspect the product to determine if any parts have been damaged or are missing.
3. If applicable, unfasten the product by removing any screws, bolts, or straps.
For your personal safety, be careful when you handle nails and straps.
4. Contact your sales representative if anything is out of order.

Product warranty

Coverage

Grindex undertakes to remedy the following faults in products sold by Grindex under the following conditions:

- The faults are due to defects in design, materials or workmanship.
- The faults are reported to an Grindex representative within the warranty period.
- The product is used only under the conditions described in this manual.
- The monitoring equipment incorporated in the product is correctly connected and in use.

- All service and repair work is done by personnel authorized by Grindex.
- Genuine Grindex parts are used.

Limitations

The warranty does not cover faults caused by the following:

- Deficient maintenance
- Improper installation
- Modifications or changes to the product and installation carried out without consulting Grindex
- Incorrectly executed repair work
- Normal wear and tear

Grindex assumes no liability for the following:

- Bodily injuries
- Material damages
- Economic losses

Warranty claim

Grindex products are high-quality products with expected reliable operation and long life. However, should the need arise for a warranty claim, please contact your Grindex representative.

Spare parts

Grindex guarantees that spare parts will be available for 10 years after the manufacture of this product has been discontinued.

Safety



WARNING:

- The operator must be aware of safety precautions to prevent physical injury.
- Any pressure-containing device can explode, rupture, or discharge its contents if it is over-pressurized. Take all necessary measures to avoid over-pressurization.
- Operating, installing, or maintaining the unit in any way that is not covered in this manual could cause death, serious personal injury, or damage to the equipment. This includes any modification to the equipment or use of parts not provided by Grindex. If there is a question regarding the intended use of the equipment, please contact an Grindex representative before proceeding.
- This manual clearly identifies accepted methods for disassembling units. These methods must be adhered to. Trapped liquid can rapidly expand and result in a violent explosion and injury. Never apply heat to impellers, propellers, or their retaining devices to aid in their removal.



CAUTION:

You must observe the instructions contained in this manual. Failure to do so could result in physical injury, damage, or delays.

User safety

General safety rules

These safety rules apply:

- Always keep the work area clean.
- Pay attention to the risks presented by gas and vapors in the work area.

- Avoid all electrical dangers. Pay attention to the risks of electric shock or arc flash hazards.
- Always bear in mind the risk of drowning, electrical accidents, and burn injuries.

Safety equipment

Use safety equipment according to the company regulations. Use this safety equipment within the work area:

- Helmet
- Safety goggles, preferably with side shields
- Protective shoes
- Protective gloves
- Gas mask
- Hearing protection
- First-aid kit
- Safety devices

NOTICE:

Never operate a unit unless safety devices are installed. Also see specific information about safety devices in other chapters of this manual.

Electrical connections

Electrical connections must be made by certified electricians in compliance with all international, national, state, and local regulations. For more information about requirements, see sections dealing specifically with electrical connections.

Hazardous liquids

The product is designed for use in liquids that can be hazardous to your health. Observe these rules when you work with the product:

- Make sure that all personnel who work with biologically hazardous liquids are vaccinated against diseases to which they may be exposed.
- Observe strict personal cleanliness.

Wash the skin and eyes

Follow these procedures for chemicals or hazardous fluids that have come into contact with your eyes or your skin:

Condition	Action
Chemicals or hazardous fluids in eyes	<ol style="list-style-type: none">1. Hold your eyelids apart forcibly with your fingers.2. Rinse the eyes with eyewash or running water for at least 15 minutes.3. Seek medical attention.
Chemicals or hazardous fluids on skin	<ol style="list-style-type: none">1. Remove contaminated clothing.2. Wash the skin with soap and water for at least 1 minute.3. Seek medical attention, if necessary.

MSHA requirements

According to the Code of Federal Regulations, the following requirements must be fulfilled to maintain permissibility of this equipment:

Subject area	Requirements
General safety	<ul style="list-style-type: none"> • Frequent inspections must be made. • All electrical parts, portable cable, and wiring must be kept in a safe condition. • There must not be any openings into the casings of the electrical parts. • The machine frame must be effectively earthed (grounded). • Power wires must not be used for earthing (grounding). • The operating voltage must match the voltage rating of the motor.
Service and repair	<ul style="list-style-type: none"> • Inspections, service, and repairs are only allowed when the portable cable is disconnected from the power supply. • Work must be performed by trained personnel (preferably the manufacturer or agent) to ensure that the pump is restored to its original state of safety in regards to all flame-arresting paths. • Replacement parts must be exactly equal to those provided by the manufacturer. • When cable entries are disturbed on pump or control, they must be reassembled in the approved manner. <div style="display: flex; align-items: center; margin-top: 10px;">  <div> <p>DANGER: Failure to restore the permissible equipment to its original state of safety will void the MSHA approval. The creation of a safety hazard will subject the owner / operator of a mine to citations and penalties under the law.</p> </div> </div>
Fastenings	All bolts, nuts, screws, and threaded covers must be properly tightened and secured.
Cables	A flame-resistant portable cable must be used. It has to bear an MSHA-assigned identification number and be adequately protected by an automatic circuit-interrupting device. Special care must be taken in handling the cable to avoid mechanical damage and wear.
Operation	Polyurethane-equipped products must not be operated dry in hazardous areas.

Environmental safety

The work area

Always keep the station clean to avoid and/or discover emissions.

Waste and emissions regulations

Observe these safety regulations regarding waste and emissions:

- Dispose appropriately of all waste.
- Handle and dispose of the processed liquid in compliance with applicable environmental regulations.
- Clean up all spills in accordance with safety and environmental procedures.
- Report all environmental emissions to the appropriate authorities.

Electrical installation

For electrical installation recycling requirements, consult your local electric utility.

Recycling guidelines

Always recycle according to the guidelines listed below:

1. Follow local laws and regulations regarding recycling if the unit or parts are accepted by an authorized recycling company.
2. If the first guideline is not applicable, then return the unit or parts to the nearest Grindex representative.

Transportation and Storage

Transportation guidelines

Precautions



WARNING:

- Stay clear of suspended loads.
 - Observe accident prevention regulations in force.
-

Position and fastening

The unit can be transported either horizontally or vertically. Make sure that the unit is securely fastened during transportation, and cannot roll or fall over.

Lifting



WARNING:

- Crush hazard. The unit and the components can be heavy. Use proper lifting methods and wear steel-toed shoes at all times.
 - Lift and handle the product carefully, using suitable lifting equipment.
 - The product must be securely harnessed for lifting and handling. Use eyebolts or lifting lugs if available.
 - Always lift the unit by its lifting handle. Never lift the unit by the motor cable or by the hose.
 - Do not attach sling ropes to shaft ends.
-

Storage guidelines

Storage location

The product must be stored in a covered and dry location free from heat, dirt, and vibrations.

NOTICE:

- Protect the product against humidity, heat sources, and mechanical damage.
 - Do not place heavy weights on the packed product.
-

Freezing precautions

The unit is frost-proof while operating or immersed in liquid, but the impeller/propeller and the shaft seal may freeze if the unit is lifted out of the liquid into a surrounding temperature below freezing.

Follow these guidelines to avoid freezing damage:

When	Guideline
Before storage	<ul style="list-style-type: none"> • The unit must be allowed to run for a short time after raising it to discharge remaining pumped liquid. This does not apply to impeller/propeller units. • The discharge opening must be covered in a suitable way, or placed facing down so that any still remaining pumped liquid runs out. • If present, the cooling jacket must be drained manually by opening the air vent screws at the top of the cooling jacket.
After storage	<p>If the impeller/propeller is frozen, it must be thawed by immersing the unit in liquid before operating the unit.</p> <hr/> <p>NOTICE: Never use a naked flame to thaw the unit.</p>

Long-term storage

If the unit is stored more than 6 months, the following apply:

- Before operating the unit after storage, it must be inspected with special attention to the seals and the cable entry.
- The impeller/propeller must be rotated every other month to prevent the seals from sticking together.

Product Description

Products included

Pump model	Approvals
Minex, 8101.171	Standard
Minex MSHA, 8101.082	MSHA (Mine Safety and Health Administration, USA): 30CFR Part 7, Approval number 07-JA080007-0

Pump design

The pump is submersible, and driven by an electric motor.

Intended use

The product is intended for moving waste water, sludge, raw and clean water. Always follow the limits given in [Application limits](#) (page 48). If there is a question regarding the intended use of the equipment, please contact an Grindex representative before proceeding.

Pumps with MSHA (Mine Safety and Health Administration, USA) certifications are designed to be used in explosive zones.



WARNING:

In explosive or flammable environments, only use Ex- or MSHA-approved pumps.

NOTICE:

Do NOT use the pump in highly corrosive liquids.

For information about pH, see [Application limits](#) (page 48).

Particle size

The pump can handle liquid containing particles that correspond to the holes in the strainer.

For more information about the strainer, see [Dimensions and weights](#) (page 51).

Pressure class

N Medium head

Impeller type

Clog resistant

Monitoring equipment

The following applies to the monitoring equipment of the pump:

- The stator incorporates thermal contacts connected in series that activate the alarm at overtemperature.
- The thermal contacts open at 125°C (257°F) and close at 95°C (203°F)
- The pump can also be equipped with level regulators.

Level regulators

About level regulators

Starting and stopping the pump at different water levels can be manual or automatic. If automatic start and stop is required, a level regulator can be ordered (as an option). The option is only available for standard pumps.

Features

Below are some of the features of the level regulators:

- The level regulator can be set at different operating levels by adjusting the length of cable.
- A clamping bracket situated at the lifting handle holds the level regulator cable in place.
- If continuous pumping is required, the level regulator can be placed in a special rubber bracket on the discharge connection to eliminate the level regulator function.

Illustration

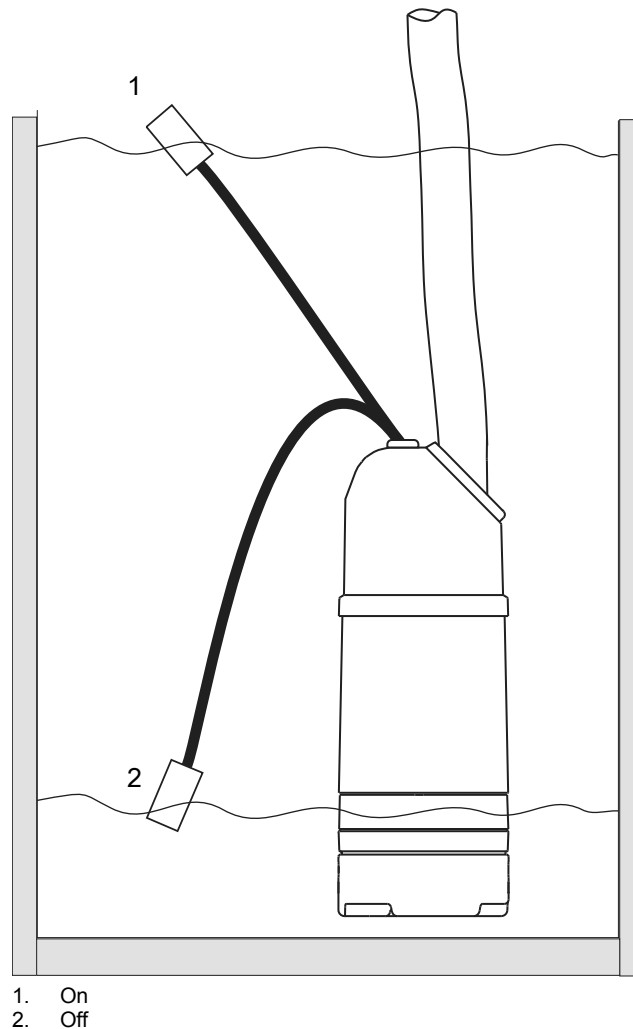

Figure 1: The functionality of the level regulator

The data plate

Introduction

The data plate is a metal label located on the main body of the pump. The data plate lists key product specifications.

The data plate

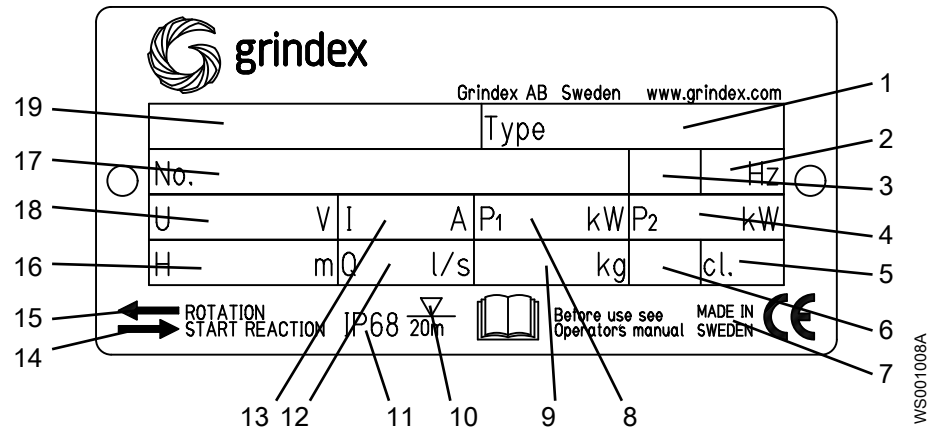

1. Pump type number
2. Frequency
3. Phases, type of current
4. Rated shaft power
5. Thermal class
6. Locked rotor code-letter
7. Country of origin
8. Maximum power consumption
9. Product weight
10. Maximum submersion depth
11. Degree of protection
12. Maximum capacity
13. Rated current
14. Direction of the start reaction
15. Direction of the impeller rotation
16. Maximum head
17. Serial number
18. Rated voltage
19. Pump model

Warning data plate

Pumps without built-in motor protection have an additional data plate.



The MSHA approval plate

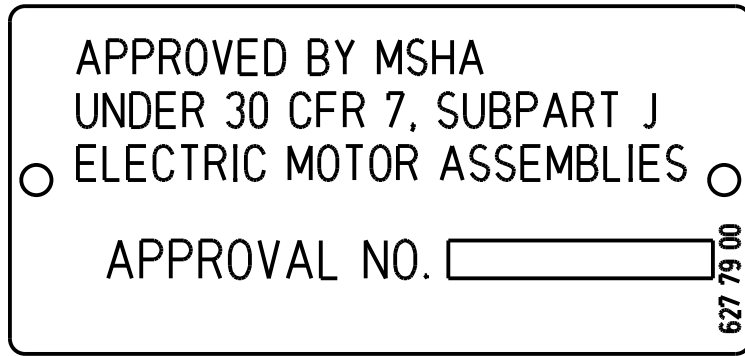

Installation

Install the pump



WARNING:

- Before installing the pump, check that the cable and cable entry have not been damaged during transportation.
- Make sure that the unit cannot roll or fall over and injure people or damage property.
- Do not install CSA-approved products in locations that are classified as hazardous in the national electric code, ANSI/NFPA 70-2005.

NOTICE:

- Never force piping to make a connection with a pump.

These requirements apply:

- Use the pump dimensional drawing in order to ensure proper installation.
- Provide a suitable barrier around the work area, for example, a guard rail.
- Check the explosion risk before you weld or use electric hand tools.
- Remove all debris from the inlet piping system before you install the pump.
- Always check the impeller rotation before lowering the pump into the pumped liquid.

Sedimentation prevention

In order to avoid sedimentation when the pumped liquid contains solid particles, the velocity of the liquid in the discharge line must exceed a certain value. Choose applicable minimum velocity from the table, and choose proper dimension of the discharge line accordingly.

Mixture	Minimum velocity, meter per second (feet per second)
Water + coarse gravel	4 (13)
Water + gravel	3.5 (11)
Water + sand, particle size <0.6 mm (0.024 in)	2.5 (8.2)
Water + sand, particle size <0.1 mm (0.004 in)	1.5 (4.9)

For more permanent installations with a heavily contaminated pumped liquid, a settling pump-sump is recommended.

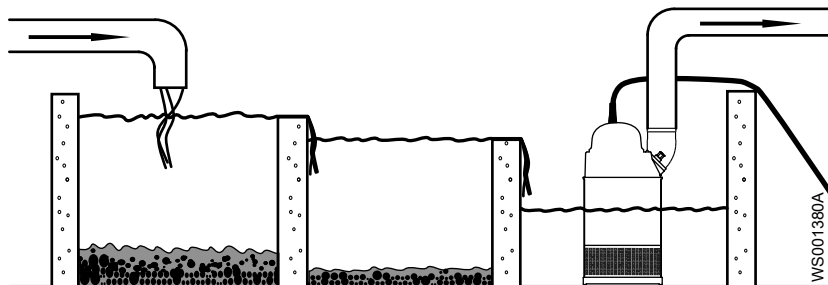
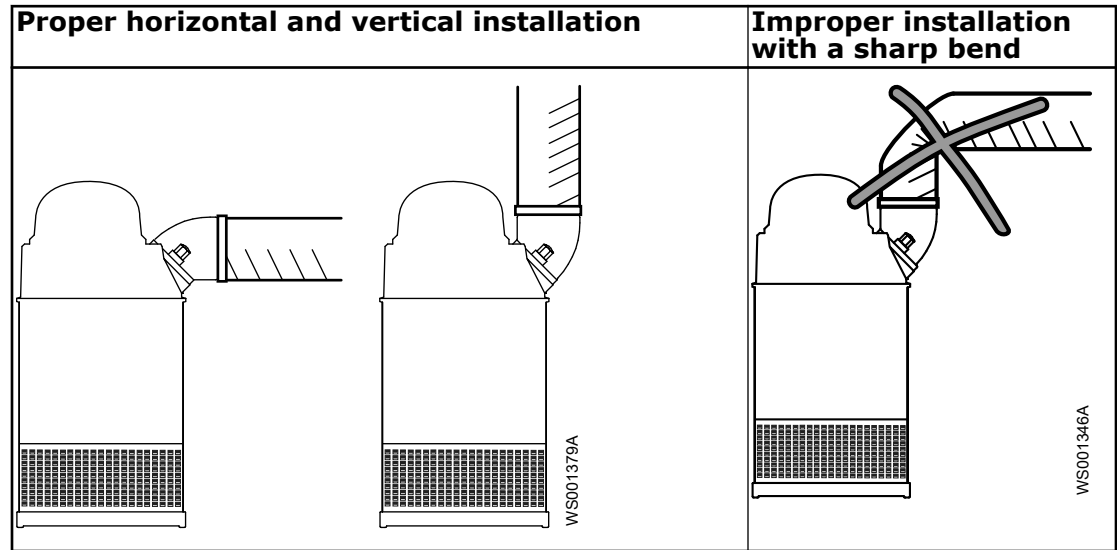

Figure 2: Settling pump-sump

Discharge line requirements

The discharge line can be run vertically or horizontally, but must be without sharp bends.



Fasteners



WARNING:

- Only use fasteners of the proper size and material.
- Replace all corroded fasteners.
- Make sure that all fasteners are properly tightened and that there are no missing fasteners.

Install

The pump is transportable and intended to operate either completely or partially submerged in the pumped liquid. The pump is equipped with a connection for hose or pipe.

These requirements and instructions only apply when the installation is made according to the dimensional drawing.

1. Run the cable so that it has no sharp bends, is not pinched, and cannot be sucked into the pump inlet.
2. Connect the discharge line.

The discharge line can be run vertically or horizontally, but must be without sharp bends.

3. Lower the pump into the sump.

The cable must not be used for this purpose. You should attach a rope or similar to the handle or the eyebolts for lowering and lifting the pump.

Heavier pumps must be lifted and lowered down by crane. Suspend the pump by the lifting handle or the eyebolts with chains or wires.

4. Place the pump on the base and make sure it cannot fall over or sink.

The base should consist of a plank, a bed of coarse gravel, or a cut-down and perforated oil drum.

Alternatively, the pump can be suspended with a lifting chain just above the sump bottom. Make sure that the pump cannot rotate at startup or during operation.

- Connect the motor cable and the starter and monitoring equipment according to the separate instructions.

Minex MSHA: Make sure that the impeller rotation is correct. For more information, see [Check the impeller rotation: Pumps without built-in motor protection](#) (page 26).

Minex: Make sure that the phase sequence is correct. For more information, see [Check the phase sequence: Pumps with built-in motor protection](#) (page 27).

Make the electrical connections

General precautions



Electrical Hazard:

- A certified electrician must supervise all electrical work. Comply with all local codes and regulations.
- Before starting work on the unit, make sure that the unit and the control panel are isolated from the power supply and cannot be energized. This applies to the control circuit as well.
- Leakage into the electrical parts can cause damaged equipment or a blown fuse. Keep the end of the motor cable above the liquid level.
- Make sure that all unused conductors are insulated.
- There is a risk of electrical shock or explosion if the electrical connections are not correctly carried out or if there is fault or damage on the product.



CAUTION:

If the pump is equipped with automatic level control and/or internal contactor, there is a risk of sudden restart.

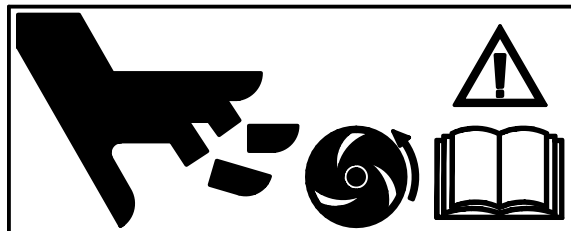

Requirements

These general requirements apply for electrical installation:

- The supply authority must be notified before installing the pump if it will be connected to the public mains. When the pump is connected to the public power supply, it may cause flickering of incandescent lamps when started.
- The mains voltage and frequency must agree with the specifications on the data plate. If the pump can be connected to different voltages, then the connected voltage is specified by a yellow sticker close to the cable entry.
- The fuses and circuit breakers must have the proper rating, and the pump overload protection (motor protection breaker) must be connected and set to the rated current according to the data plate and if applicable the cable chart. The starting current in direct-on-line start can be up to six times higher than the rated current.
- The fuse rating and the cables must be in accordance with the local rules and regulations.

- If intermittent operation is prescribed, then the pump must be provided with monitoring equipment supporting such operation.
- The thermal contacts/thermistors must be in use.

Cables

These are the requirements to follow when you install cables:

- The cables must be in good condition, not have any sharp bends, and not be pinched.
- The sheathing must not be damaged and must not have indentations or be embossed (with markings, etc.) at the cable entry.
- The cable entry seal sleeve and washers must conform to the outside diameter of the cable.
- The minimum bending radius must not be below the accepted value.
- If using a cable which has been used before, a short piece must be peeled off when refitting it so that the cable entry seal sleeve does not close around the cable at the same point again. If the outer sheath of the cable is damaged, then replace the cable. Contact a Grindex service shop.
- The voltage drop in long cables must be taken into account. The drive unit's rated voltage is the voltage measured at the cable connection point in the pump.

Earthing (Grounding)



Electrical Hazard:

- You must earth (ground) all electrical equipment. This applies to the pump equipment, the driver, and any monitoring equipment. Test the earth (ground) lead to verify that it is connected correctly.
- If the motor cable is jerked loose by mistake, the earth (ground) conductor should be the last conductor to come loose from its terminal. Make sure that the earth (ground) conductor is longer than the phase conductors. This applies to both ends of the motor cable.
- Risk of electrical shock or burn. You must connect an additional earth-(ground-) fault protection device to the earthed (grounded) connectors if persons are likely to come into physical contact with the pump or pumped liquids.

Earth (ground) conductor length

The earth (ground) conductor must be 200 mm (7.9 in.) longer than the phase conductors in the junction box of the unit.

Product-specific precautions



Electrical Hazard:

This information is valid only for standard version products:

For a pump with a level regulator and a cable with earth (ground) check: Make sure that the earth (ground) check connection is done at the GC-connection point with a stud and two nuts. Do the connection first with the cable and one nut, and subsequently with the level regulator and the other nut.

Switch between higher and lower supply voltages



Electrical Hazard:

The thermal contacts in the winding are CSA approved only for 250 V and below. When CSA approval is required for higher voltages, then you must use a transformer to reduce the voltage over the thermal contacts. You must make the switch between 440–460 V Y serial and 220–240 V Y parallel or to 230 V single phase according to the appropriate instructions. Read the manual for details.

This procedure only applies to the standard version of the product.

Select one of these actions, depending on switch direction:

Switch direction	Action
From 440–460 V Y serial to either 220–240 V Y parallel or 230 V single phase	Disconnect the transformer.
From either 220–240 V Y parallel or 230 V single phase to 440–460 V Y serial	Connect the transformer.

Connect the motor cable to the pump



CAUTION:

Leakage into the electrical parts can cause damaged equipment or a blown fuse. Keep the end of the motor cable above the liquid level.

1. Check the data plate to see which connections are required for the power supply.
2. Connect the motor cable conductors, including earth (ground), to the terminal or starter unit.
3. Make sure that the pump is correctly connected to earth (ground).
4. Firmly tighten the cable entry into its bottom-most position.
The seal sleeve and the washers must conform to the outside diameter of the cables.



WARNING:

Do not install the starter equipment in an explosive zone unless it is explosion-proof rated.

Cable charts for connection with sealed terminal plate, standard version

Description

This topic provides cable charts that show connection alternatives with sealed terminal plate, for use with different cables and power supply.

Connection locations

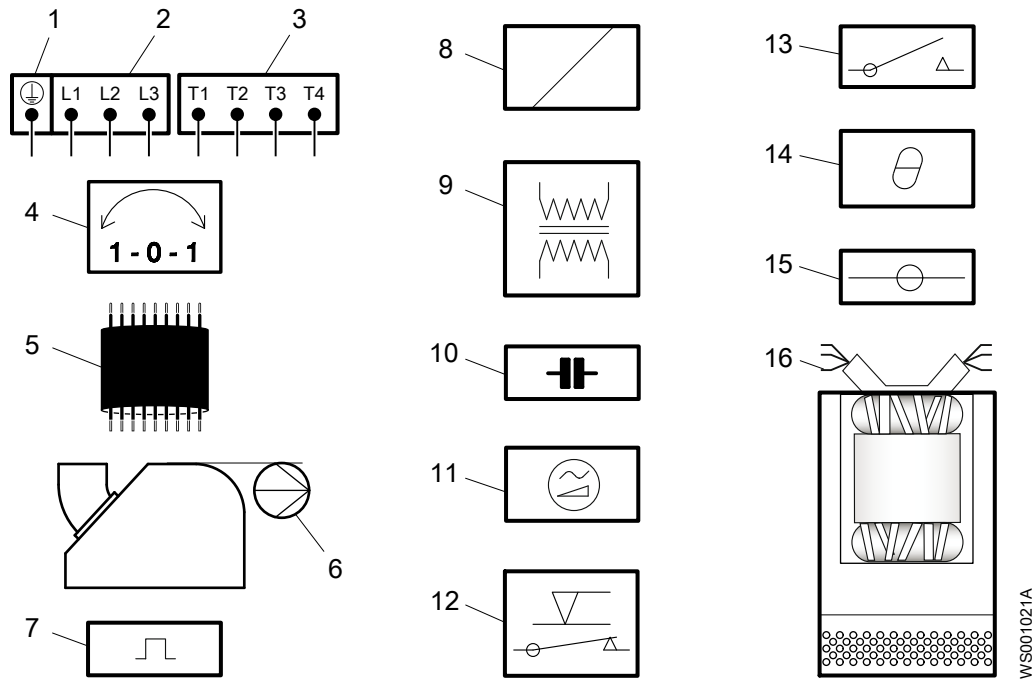

1. Earth (ground)
2. Starter equipment and main leads (L1, L2, L3)
3. Control leads (T1, T2, T3, T4)
4. Phase shifter
5. Motor cable, minimum 20 m (66 ft.)
6. Pump
7. Motor protector
8. Coil
9. Transformer
10. Capacitor
11. Softstarter
12. Level regulator
13. Contactor, start relay or thermal relay
14. Thermal contact
15. Terminal board, terminal plate
16. Stator leads (U1, U2, U5, U6, V1, V2, V5, V6, W1, W2, W5, W6, Z1, Z5, Z6)

Color code standard

Code	Description
BN	Brown
BK	Black
WH	White
OG	Orange
GN	Green
GNYE	Green-Yellow
RD	Red
BU	Blue
YE	Yellow

Terminal plate markings, 1-phase

Marking	Description
A	Auxiliary winding
C	Common
M	Main winding

Stator leads and thermal contacts connection to the terminal plate

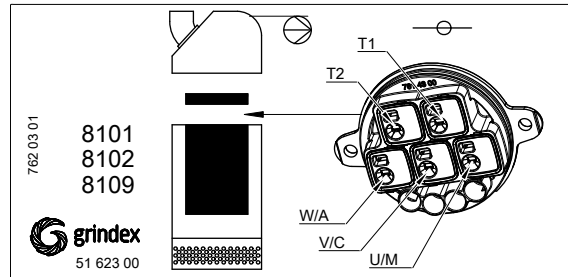

WS001022B

Terminal plate	4 leads	serial 8 leads	// 8 leads	Terminal plate markings 1-phase: A=Auxiliary winding C=Common M=Main winding	STATOR LEADS 1-ph U1,Z5 RD U6 GN U2, Z6 BN U5, Z1 YE Z2 BK T1,T2 WH/YE
	W / A	Z2	Z6		
V / C	Z1 U2	Z1 U6	U2 U6 Z1 Z5		
U / M	U1	U1	U1 U5		
T1	T1	T1	T1		
T2	T2	T2	T2		
		Z2 • Z5 U2 • U5			

Terminal plate	3 leads Y	6 leads D	6 leads Y	9 leads Y serial	9 leads Y //	12 leads Y //	12leads D serial	12 leads D //	STATOR LEADS 3-ph U1,U5 RD U2,U6 GN V1,V5 BN V2,V6 Blue W1,W5 YE W2,W6 BK T1,T2 WH/YE
	W / A	W	W1 V2	W1	W1	W1 W5	W1 W5	W1 V6	
V / C	V	V1 U2	V1	V1	V1 V5	V1 V5	V1 U6	V1 V5 U2 U6	
U / M	U	U1 W2	U1	U1	U1 U5	U1 U5	U1 W6	U1 U5 W2 W6	
T1	T1	T1	T1	T1	T1	T1	T1	T1	
T2	T2	T2	T2	T2	T2	T2	T2	T2	
		W2 • V2 U2 • U2	W2 • W5 V2 • V5 U2 • U5	W2 • V2 U2 • U2	W2 • W6 V2 • V6 U2 • U6	W2 • W5 V2 • V5 U2 • U5			

Figure 3

Motor cable and starter unit connection to the terminal plate

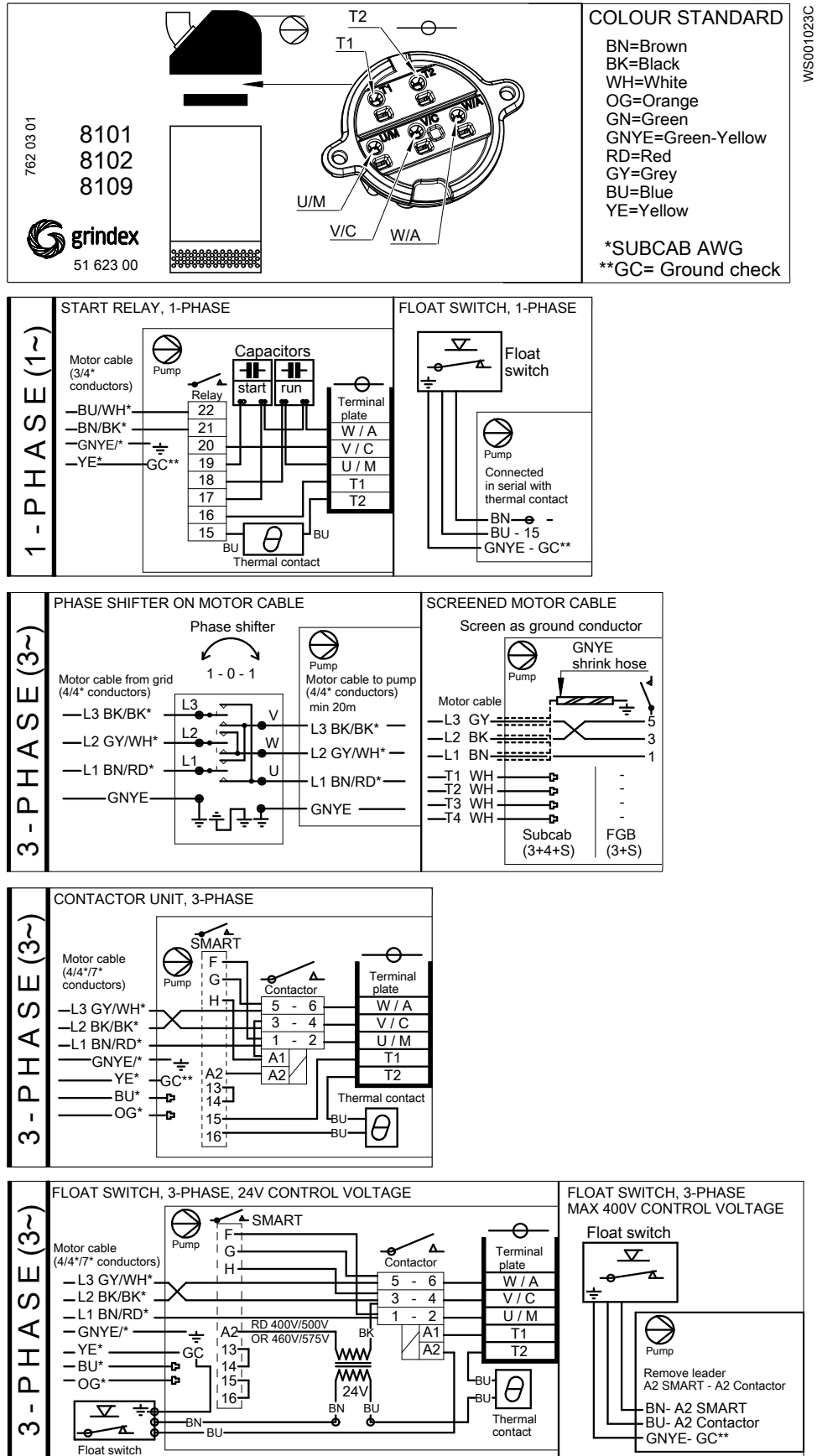

WS001023C

Figure 4

Cable charts for connection without sealed terminal plate, standard version

Description

This topic provides cable charts that show connection alternatives without sealed terminal plate, for use with different cables and power supply.

50/60 Hz, 1-phase, with contactor unit, with or without level regulator

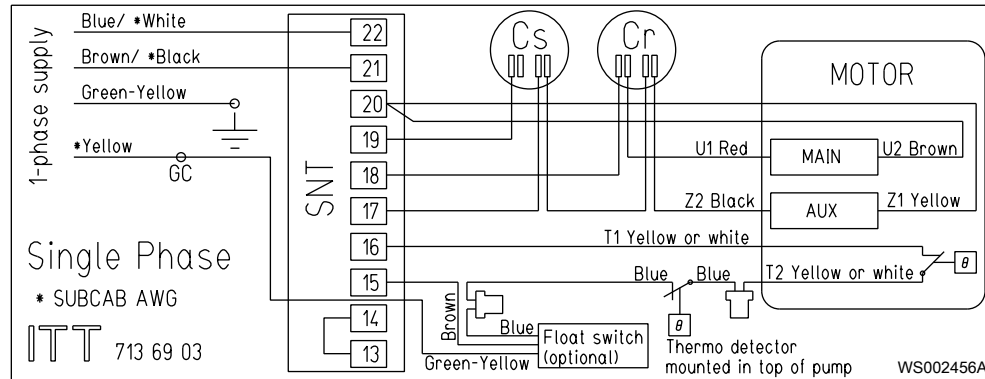

50/60 Hz, 3-phase, with contactor unit, Y or D connection, with or without transformer operation

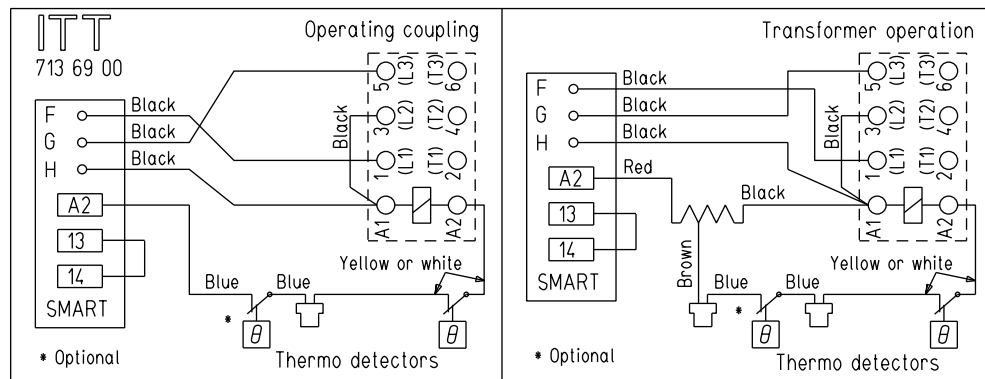
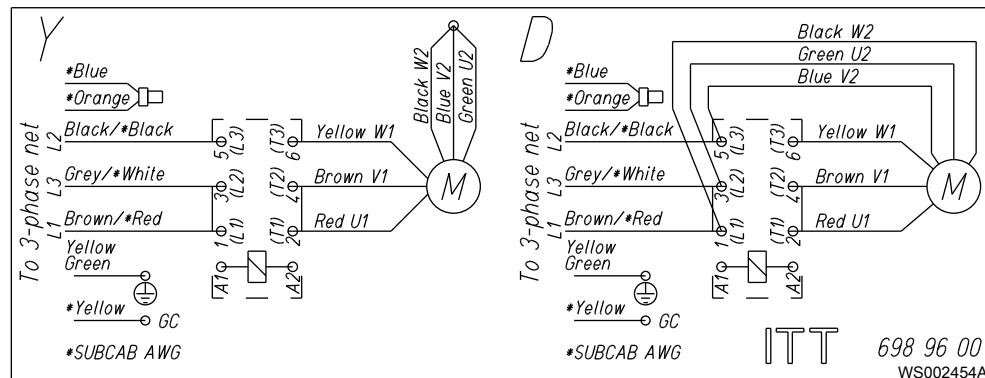

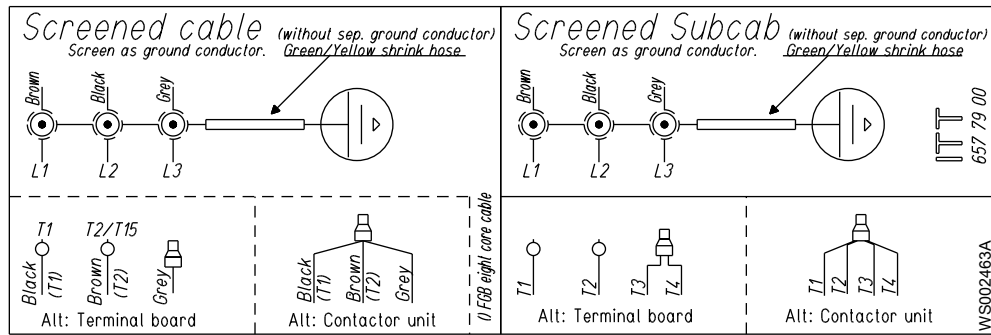

50/60 Hz, 3-phase, with contactor unit, Y or D connection, with level regulator

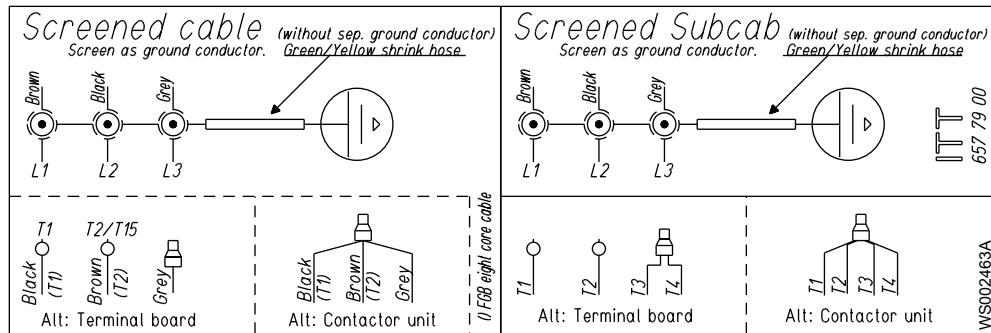
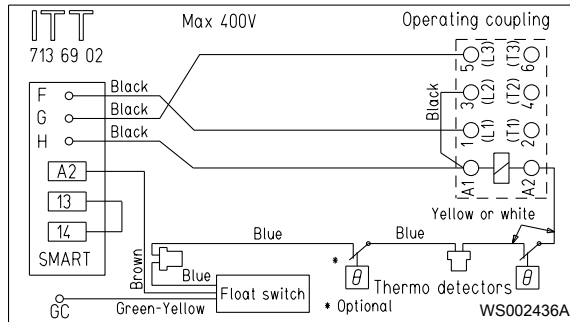
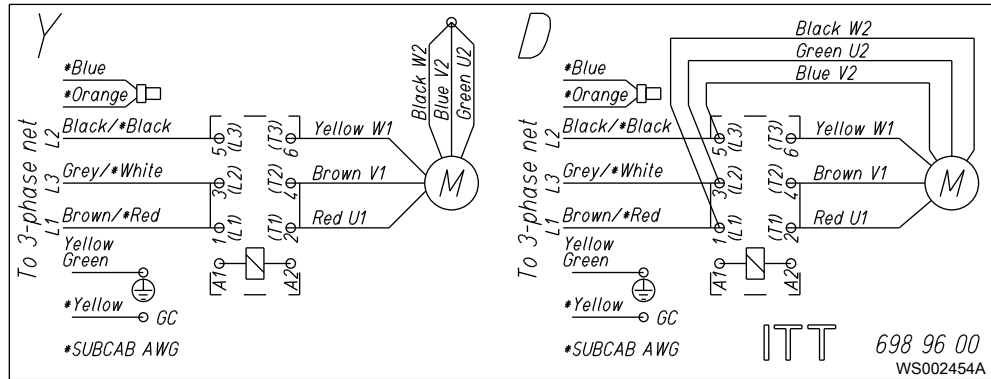

50/60 Hz, 3-phase, with contactor unit, Y serial or Y parallel connection, with or without transformer operation

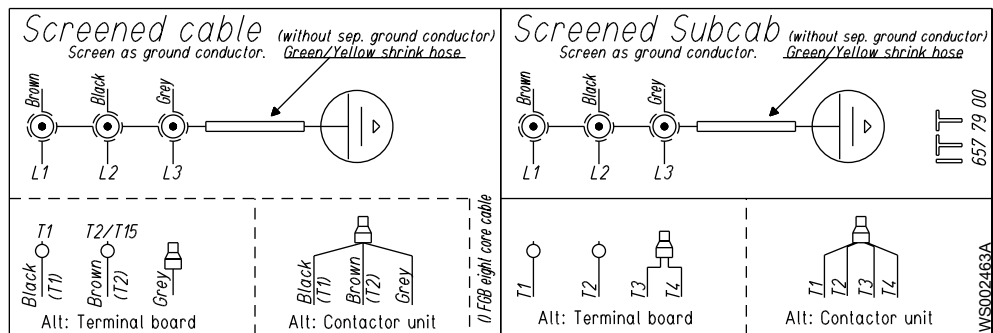
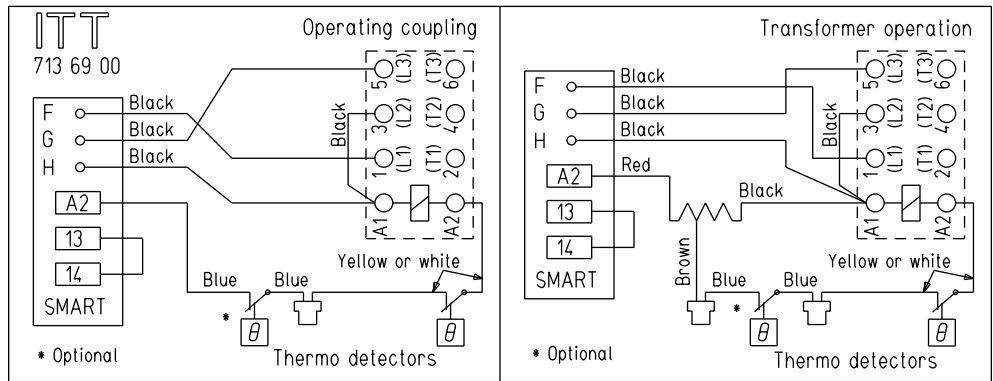
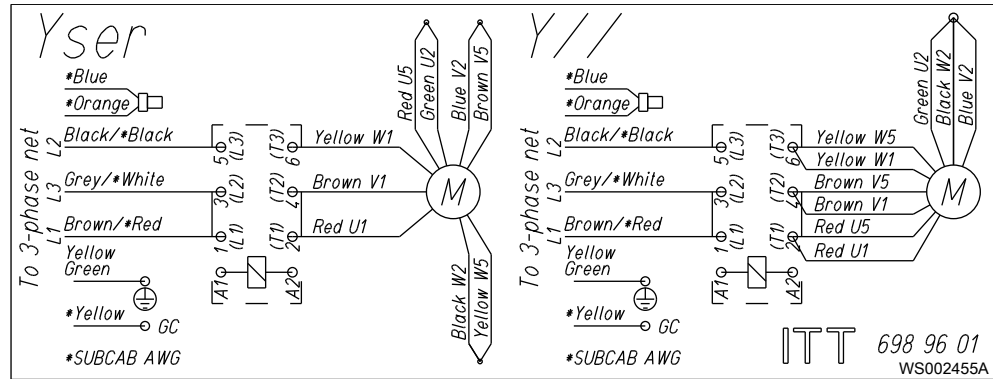

Cable charts, MSHA version

60 Hz, 1-phase, 230V serial or 115V parallel

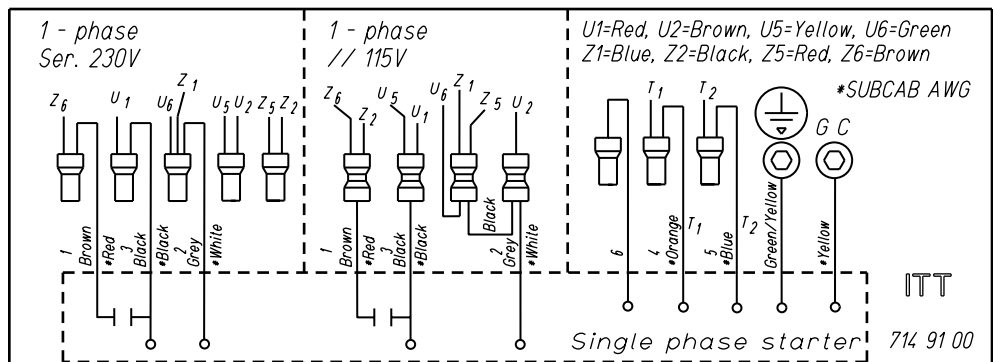
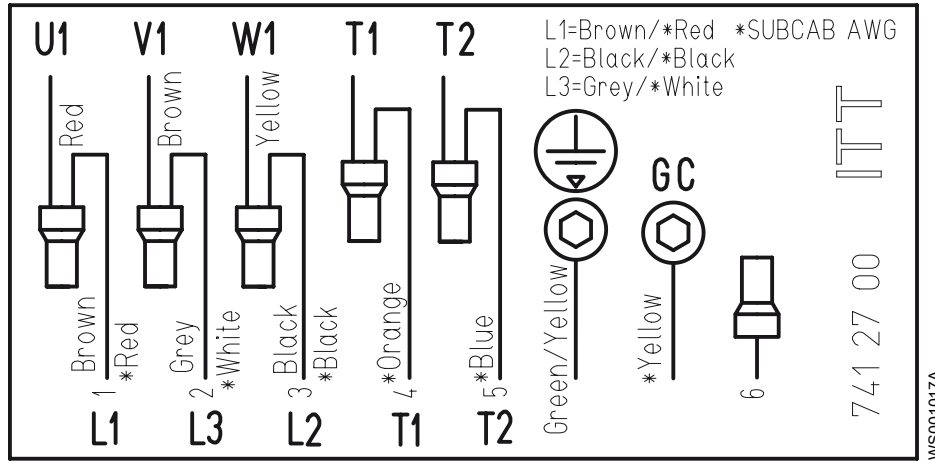

Figure 5

60 Hz, 3-phase



Check the impeller rotation: Pumps without built-in motor protection

Follow this procedure if your product does not have the rotation control SMART™.



WARNING:

The starting jerk can be powerful.

Check the direction of rotation each time the cable has been re-connected and after phase or total supply failure.

1. Start the motor.
2. Stop the motor.
3. Check that the impeller rotates in the correct direction.

The correct direction of impeller rotation is clockwise when you look at the pump from above. When started, the pump will react in the opposite direction to the impeller rotation.

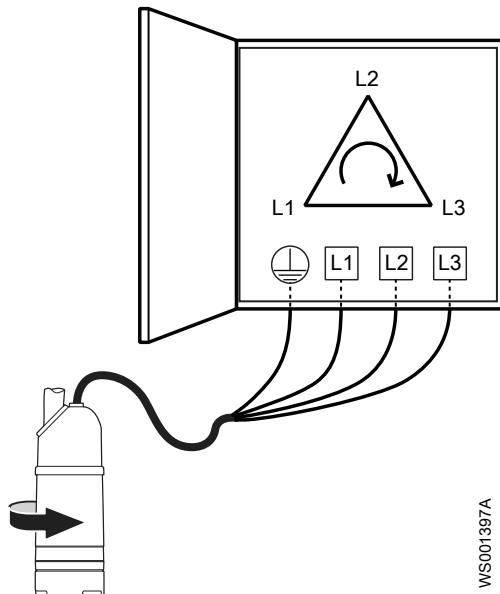

Figure 6: Start reaction

4. If the impeller rotates in the wrong direction, then do the following:
 - If the motor has a 1-phase connection, then contact the local Grindex shop.
 - If the motor has a 3-phase connection, then transpose two phase conductors and repeat this procedure from step 1.

For 3-phase pumps with external starters or without built-in motor protection, the phases must be shifted on the output terminal of the starter.

Check the phase sequence: Pumps with built-in motor protection

Follow this procedure if your product is equipped with the rotation control SMART™.



WARNING:

The starting jerk can be powerful.

The correct direction of impeller rotation is clockwise when you look at the pump from above. When started, the pump will react in the opposite direction to the impeller rotation.

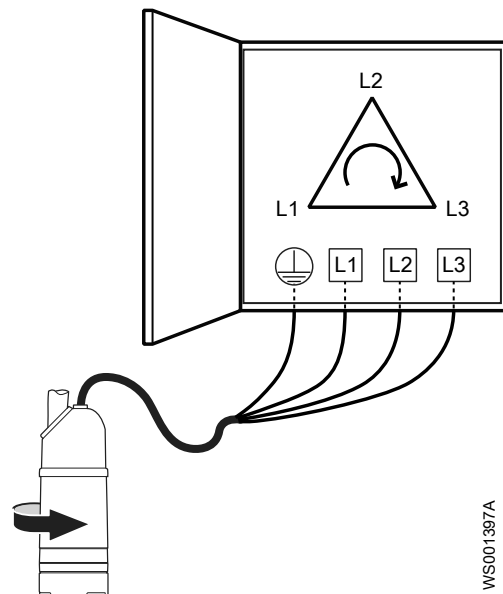
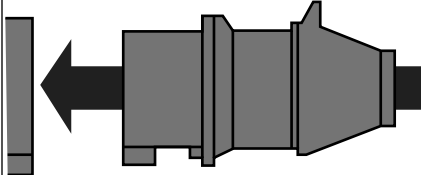
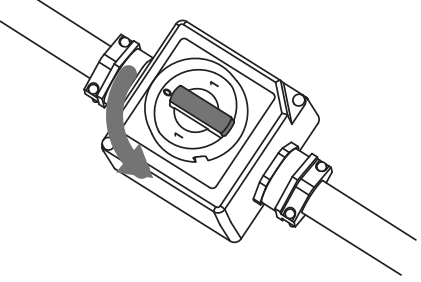

Figure 7: Start reaction

1. Connect the pump to power as follows:

Condition	Action
The pump has a CEE plug with internal phase shifter.	Connect the plug. 
The pump has a phase shifter with an on/off switch.	Turn the knob on the phase shifter in either direction.

Condition	Action
	
<p>The pump has neither a CEE plug with internal phase shifter, nor a phase shifter with an on/off switch.</p>	<ol style="list-style-type: none"> 1. Connect the pump to power. 2. Switch on the power.

The pump should start. If it does not, then continue to the next step.

2. If the pump does not start and the fuses are correct, then shift two phases:

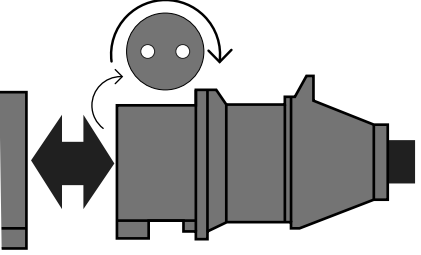
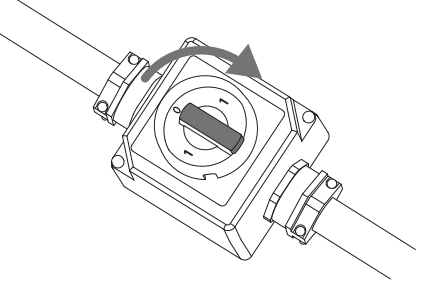
Condition	Action
<p>The pump has a CEE plug with internal phase shifter.</p>	<ol style="list-style-type: none"> 1. Pull out the plug. 2. Shift two phases. 3. Wait until the motor has stopped. 4. Connect the plug. 
<p>The pump has a phase shifter with an on/off switch.</p>	<ol style="list-style-type: none"> 1. Turn the knob on the phase shifter to neutral position. 2. Wait until the motor has stopped. 3. Turn the knob to the opposite position from before. 
<p>The pump has neither a CEE plug with internal phase shifter, nor a phase shifter with an on/off switch.</p>	<p>Transpose two phase leads on the output terminal of the starter.</p>

NOTICE:

Do not reverse the phase sequence while the pump is running. Temporarily incorrect rotation can occur, resulting in damage to motor electronics and rotating parts.

The pump should start. If it does not, then contact a certified electrician to check the mains and the junctions.

Operation

Precautions

- Never operate the pump without safety devices installed.
- Never operate the pump with the discharge valve closed.
- Make sure that all safety guards are in place and secure.
- Make sure you have a clear path of retreat.
- Never work alone.
- Beware of the risk of a sudden start if the product is used with an automatic level control and/or internal contactor.

Distance to wet areas



Electrical Hazard:

Risk of electrical shock. Make sure no one gets closer than 20 m (65 ft.) to the unit when being in contact with the pumped or mixed liquid.



Electrical Hazard:

Risk of electrical shock. This unit has not been investigated for use in swimming pools. If used in connection with swimming pools special safety regulations apply.

Noise level

NOTICE:

The noise level of the product is lower than 70 dB. However, the noise level of 70 dB may be exceeded in some installations and at certain operating points on the performance curve. Make sure that you understand the noise level requirements in the environment where the pump is installed. Failure to do so may result in hearing loss or violation of local laws.

Start the pump



WARNING:

- If you need to work on the pump, make sure that it is isolated from the power supply and cannot be energized.
 - Make sure that the unit cannot roll or fall over and injure people or damage property.
 - In some installations, the pump and the surrounding liquid may be hot. Bear in mind the risk of burn injuries.
 - Make sure nobody is close to the unit when it is started. The unit will jerk in the opposite direction of the impeller rotation.
-

NOTICE:

Make sure that the rotation of the impeller is correct. For more information, see Check the impeller rotation.

1. Check the oil level in the oil housing.
 2. Remove the fuses or open the circuit breaker, and check that the impeller can be rotated freely.
-

3. Check that the monitoring equipment (if any) works.
4. Check that the impeller rotation is correct.
5. Start the pump.

Clean the pump

The pump must be cleaned if it has been running in very dirty water. If clay, cement or other similar dirt is left in the pump it may clog the impeller and seal, preventing the pump from working.

Let the pump run for a while in clean water, or flush it through the discharge connection.

Maintenance

Precautions



WARNING:

- Always follow safety guidelines when working on the pump. See [Introduction and Safety](#) (page 3).
- Disconnect and lock out electrical power before installing or servicing the pump.
- Make sure that the unit cannot roll or fall over and injure people or damage property.
- Rinse the pump thoroughly with clean water before working on the pump.
- Rinse the components in water after dismantling.

Make sure that you follow these requirements:

- Check the explosion risk before you weld or use electrical hand tools.
- Allow all system and pump components to cool before you handle them.
- Make sure that the product and its components have been thoroughly cleaned.
- Do not open any vent or drain valves or remove any plugs while the system is pressurized. Make sure that the pump is isolated from the system and that pressure is relieved before you disassemble the pump, remove plugs, or disconnect piping.

Maintenance guidelines

During maintenance and before reassembly, always remember to perform these tasks:

- Clean all parts thoroughly, particularly O-ring grooves.
- Change all O-rings, gaskets, and seal washers.
- Lubricate all springs, screws, and O-rings with grease.

During reassembly, always make sure that existing index markings are in line.

Torque values

Lubricate all screws and nuts to reach correct tightening torque. Screws that are screwed into stainless steel must have the threads coated with suitable lubricants to prevent seizing.

If there is a question regarding the tightening torques, please contact a sales representative.

Screws and nuts

Table 1: Stainless steel, A2 and A4, torque Nm (ft-lbs)

Property class	M4	M5	M6	M8	M10	M12	M16	M20	M24	M30
50	1.0 (0.74)	2.0 (1.5)	3.0 (2.2)	8.0 (5.9)	15 (11)	27 (20)	65 (48)	127 (94)	220 (162)	434 (320)

Property class	M4	M5	M6	M8	M10	M12	M16	M20	M24	M30
70, 80	2.7 (2)	5.4 (4)	9.0 (6.6)	22 (16)	44 (32)	76 (56)	187 (138)	364 (268)	629 (464)	1240 (915)

Table 2: Steel, torque Nm (ft-lbs)

Property class	M4	M5	M6	M8	M10	M12	M16	M20	M24	M30
8.8	2.9 (2.1)	5.7 (4.2)	9.8 (7.2)	24 (18)	47 (35)	81(60)	194 (143)	385 (285)	665 (490)	1310 (966)
10.9	4.0 (2.9)	8.1 (6)	14 (10.3)	33 (24.3)	65 (48)	114 (84)	277 (204)	541 (399)	935 (689)	1840 (1357)
12.9	4.9 (3.6)	9.7 (7.2)	17 (12.5)	40 (30)	79 (58)	136 (100)	333 (245)	649 (480)	1120 (825)	2210 (1630)

Hexagon screws with countersunk heads

For hexagon socket head screws with countersunk head, maximum torque for all property classes must be 80% of the values for property class 8.8 above.

Service

Regular inspection and service of the pump ensures more reliable operation.

Type of service	Purpose	Inspection interval
Inspection	To prevent operational interruptions and machine breakdown. Measures to secure performance and pump efficiency are defined and decided for each individual application. It can include such things as impeller trimming, wear part control and replacement, control of zinc-anodes and control of the stator.	Twice a year or every 2,000 hours
Major overhaul	To secure a long operating lifetime for the product. It includes replacement of key components and the measures taken during an inspection.	Every year, under normal operating conditions

NOTICE:

Shorter intervals may be required when the operating conditions are extreme, for example with very abrasive or corrosive applications or when the liquid temperatures exceed 40°C (104°F).

Inspection

Regular inspection and service of the pump ensures more reliable operation.

Service item	Action
Visible parts on the pump and installation	<ol style="list-style-type: none"> 1. Check that all screws, bolts, and nuts are properly tightened. 2. Check the condition of lifting handles, eye bolts, ropes, chains, and wires. 3. Check for worn or damaged parts. 4. Adjust and/or replace if necessary.

Service item	Action
Pipes, valves, and other peripheral equipment	<ol style="list-style-type: none"> 1. Check for worn or damaged parts. 2. Adjust and/or replace if necessary.
Pump casing and impeller	<ol style="list-style-type: none"> 1. Check for worn or damaged parts. 2. Adjust and/or replace if necessary. <p>Wear on the impeller or surrounding parts necessitates fine adjustments of the impeller or replacement of worn parts. See Replace the impeller (page 36).</p>
Oil	<p>Check the water and oil mixture as follows:</p> <ol style="list-style-type: none"> 1. Insert a tube or hose into the oil hole. 2. Cover the top end of the tube. 3. Take up a little oil from the bottom. (Air/oil mixture can be confused with water/oil mixture.) 4. If the mixture contains too much water, in other words if it is heavily emulsified (creamlike) or if the water has settled out, then change the oil. See Change the oil (page 35). Check again one week after changing the oil.
Cable entry	<ol style="list-style-type: none"> 1. Check that the following requirements are met: <ul style="list-style-type: none"> • The cable entry must be firmly tightened into its bottom-most position. • MSHA pump version: The inner cable entry must be tightened so that the clearance between the entrance flange and the MSHA cover is >3.175 mm (1/8 in.). Use a feeler gauge to check the clearance. • MSHA pump version: The lock washer lips must be folded to secure the cable entry screws. • The seal sleeve and the washers must conform to the outside diameter of the cables. 2. Cut off a piece of the cable so that the seal sleeve closes around a new position on the cable. 3. Replace the seal sleeve, if necessary.
Inspection chamber ¹	<ol style="list-style-type: none"> 1. Check that the inspection screw is properly tightened. 2. Remove the inspection screw. 3. Drain all liquid, if any. 4. If there is oil in the inspection chamber, then check that the inner mechanical seal is not damaged. If necessary, contact an authorized service shop. 5. If there is water in the inspection chamber, then do the following: <ol style="list-style-type: none"> a. Check that the O-ring is not damaged. b. Check that the cable entry does not have any leakage.
Cable	<ol style="list-style-type: none"> 1. If the outer jacket is damaged, replace the cable. 2. Check that the cables do not have any sharp bends and are not pinched.
Cooling system	If the flow through the system has been partly restricted, then rinse and clean.

¹ Regardless of individual applications, the inspection chamber should not be inspected less frequently than the intervals for normal applications and operating conditions at media (liquid) temperatures <40°C (104°F).

Service item	Action
Level sensors or other sensor equipment	<ol style="list-style-type: none"> 1. Check the functionality. 2. Repair or replace any damaged equipment. 3. Clean and adjust the equipment.
Starter equipment	<ol style="list-style-type: none"> 1. Check the condition and functionality. 2. Contact an electrician, if necessary.
Insulation resistance in the stator	<ol style="list-style-type: none"> 1. Check the insulation between: <ul style="list-style-type: none"> • Phase-phase on the stator • Phase-earth (ground) The insulation should be > 1 megohm. Use a 1000-VDC megger to test the insulation. 2. If the resulting value is < 1 megohm, then contact an authorized service shop.

Major overhaul

For a major overhaul, take this action in addition to the tasks listed under Inspection.

Service item	Action
Support and main bearing	Replace the bearings with new bearings.
Mechanical seal	Replace with new seal units.

Change the oil

A paraffin oil with viscosity close to ISO VG32 is recommended. The pump is delivered from the factory with this type of oil. In applications where poisonous properties are of less concern, a mineral oil with viscosity up to ISO VG32 can be used.

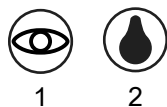

1. Inspection screw
2. Oil screw

Figure 8: Symbols

Empty the oil

1. Lay the pump on its side.
Lock the pump with supports to prevent it from rolling over.
2. Remove the oil screw.

There are two oil screws. Either screw can be used for drainage, but it is easier to drain the oil if both oil screws are removed.



WARNING:

The oil housing may be pressurized. Hold a rag over the oil plug to prevent oil from spraying out.

3. Turn the pump so that the oil hole faces downwards and let the oil run out.

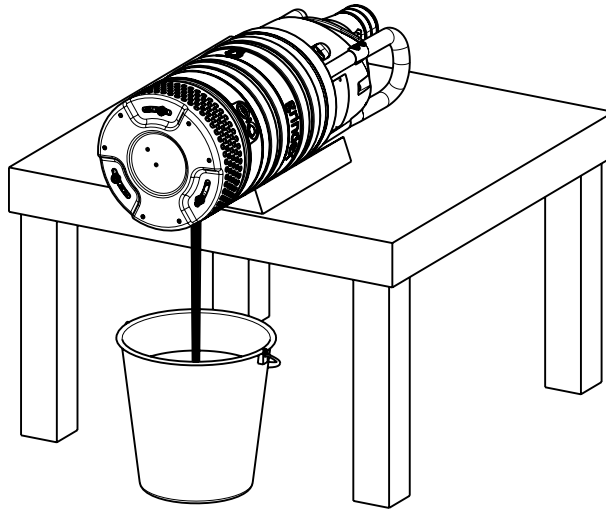

Fill with oil

1. Replace the oil screw O-ring.
2. Put one of the oil screws back and tighten it.
3. Turn the pump so that the oil hole faces upwards and fill with new oil.
Quantity: 0.22 L (0.23 qt.)
4. Put the oil screw back and tighten it.

Replace the impeller

Remove the impeller N, H



WARNING:

A worn impeller and/or pump housing can have very sharp edges. Wear protective gloves.

1. Remove the strainer.

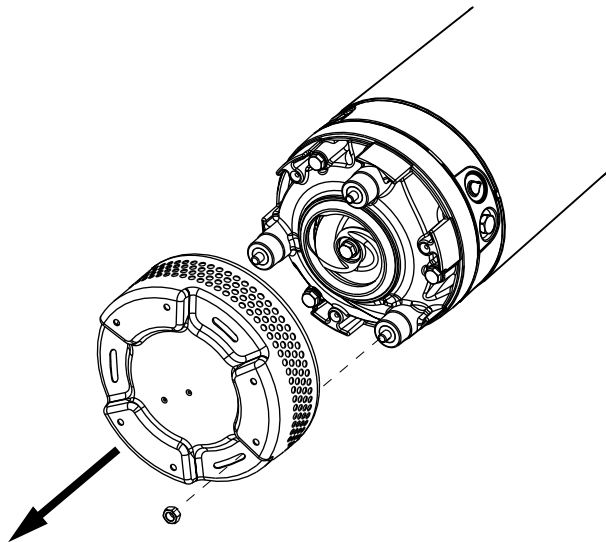

2. Remove the suction cover.
3. Remove the O-ring.
4. Loosen the impeller:
 - a) Lock the impeller to prevent rotation.

- Use pliers, a screwdriver, or similar.
b) Remove the impeller screw and washer.

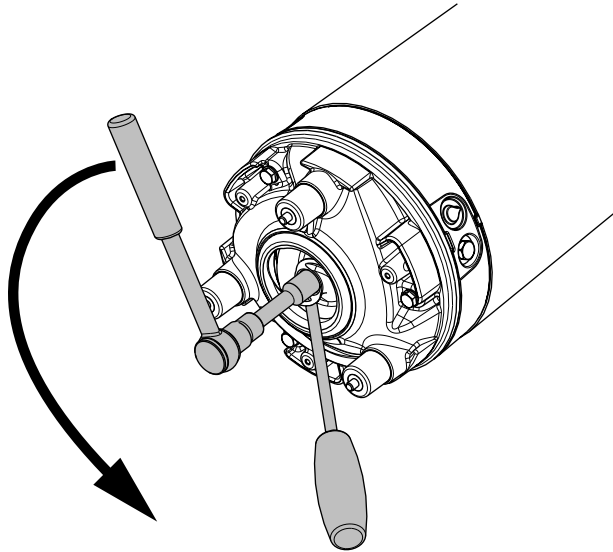

5. Remove the diffuser.

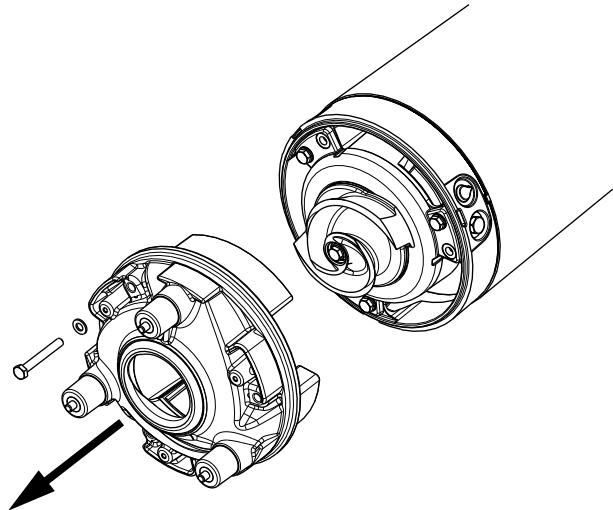

6. Remove the impeller:
a) Lock the impeller to prevent rotation.
Use pliers, a screwdriver, or similar.
b) Turn the adjustment screw counterclockwise until the impeller breaks free from the shaft.
Use an 8 mm hexagon bit adapter (Allen socket) with a 100 mm (4 in.) extension.

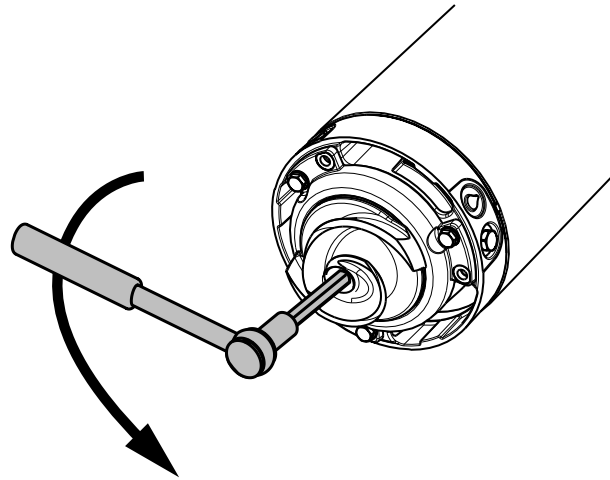

c) Pull off the impeller.

Install the impeller N, H

1. Prepare the shaft:
 - a) Polish off any flaws with a fine emery cloth.
The end of the shaft must be clean and free from burrs.
 - b) Grease the end of the shaft, the conical sleeve, and the threads of the adjustment screw.
The proper lubrication is grease for bearings, for example Exxon Mobil Unirex N3, Mobil Mobilith SHC 220 or equivalent.

NOTICE:

The impeller can become loose. Remove any surplus grease from conical and cylindrical surfaces of shafts and sleeves.

2. Align the edge of the adjustment screw with the edge of the conical sleeve so that they are flush.

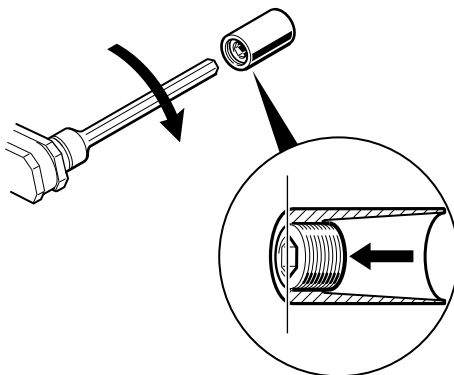

3. Grease the threads of the screw and the washer.
The proper lubrication of the screw and washer is lubricating grease for assembly of bolts etc., for example, Kluber ALTEMP Q NB 50 or equivalent.
4. Check that the impeller screw is clean and easy to screw into the shaft end.
This is to prevent the shaft from rotating with the impeller screw.
5. Assemble the conical sleeve and the impeller onto the shaft.

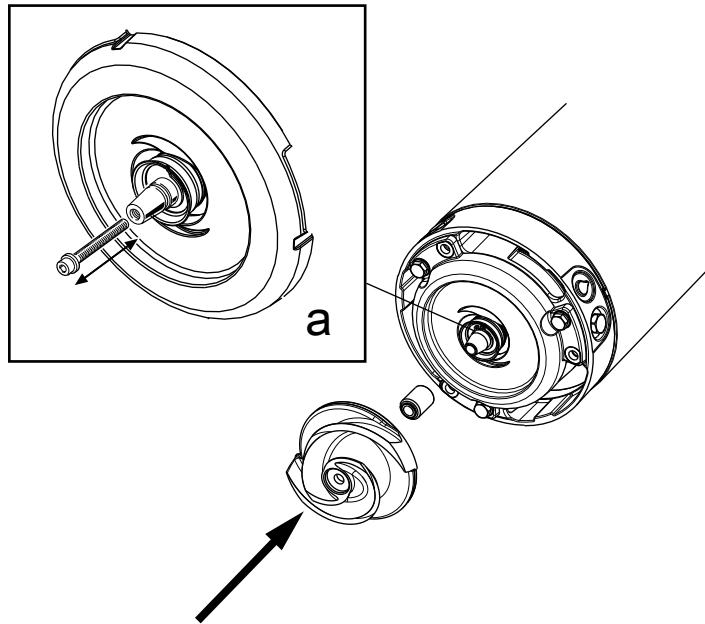

6. Mount the diffuser part and tighten.
Tightening torque: 22 Nm (16.2 ft-lbs)

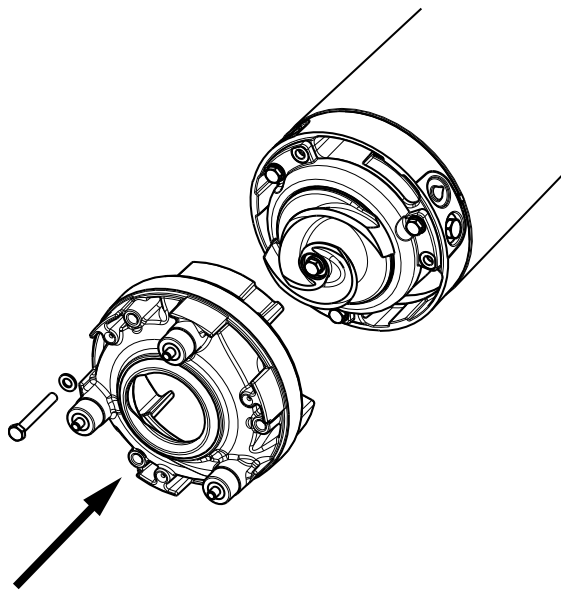

7. Check that the impeller can rotate easily.
If not, the adjustment screw and the conical sleeve have not been aligned, and the shaft may have been displaced relative to the main bearing.
8. Turn the adjustment screw clockwise until the impeller makes contact with the suction cover. Tighten a further 1/8 turn, 45°.
This will ensure the correct clearance between the impeller and the suction cover in the next step.
Use an 8 mm hexagon bit adapter (Allen socket) with a 100 mm (4 in.) extension.

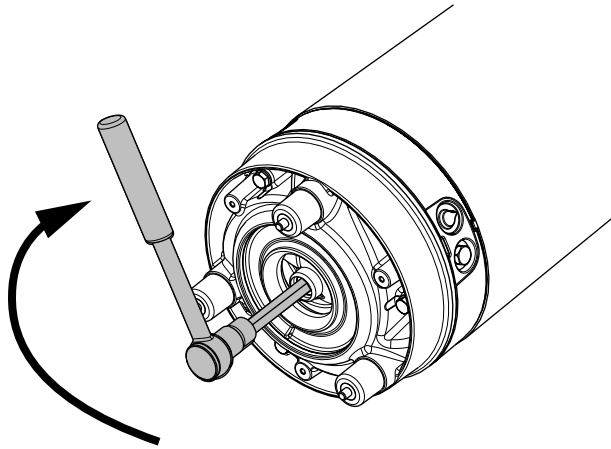

9. Fasten the impeller:

- a) Place the washer on the impeller screw.
- b) Lock the impeller to prevent rotation.
Use pliers, a screwdriver, or similar.
- c) Tighten the impeller screw.

Tightening torque: 22 Nm (16.2 ft-lbs)

- d) Tighten a further 1/8 turn, 45°.

The screw will be loaded to its yield point and the load capacity of the joint will be higher.

- e) Check that the impeller can rotate easily.

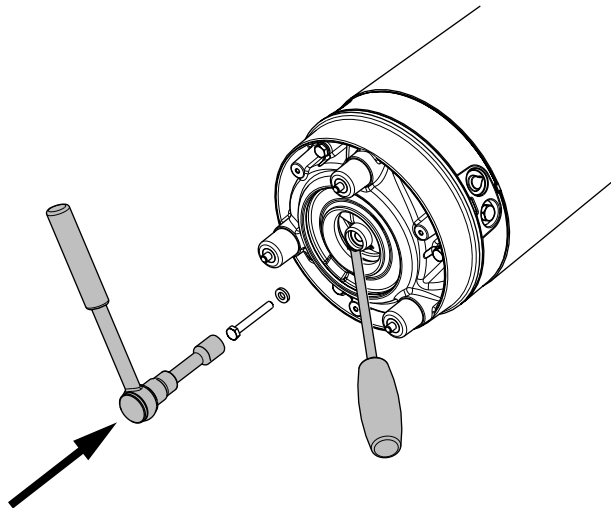

10. Mount the strainer and the nuts.

Tightening torque: 17 Nm (12.5 ft-lbs)

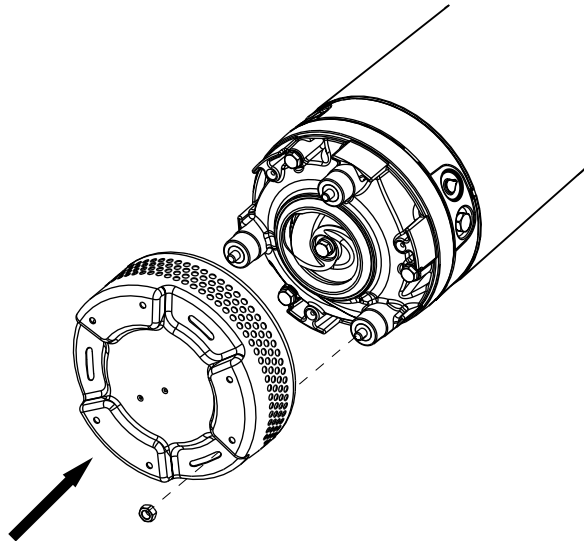

Troubleshooting

Introduction

Follow these guidelines when troubleshooting the pump:

- Disconnect and lock out the power supply except when conducting checks that require voltage.
- Make sure that no one is near the pump when the power supply is reconnected.
- When troubleshooting electrical equipment, use the following:
 - Universal instrument multimeter
 - Test lamp (continuity tester)
 - Wiring diagram

The pump does not start, for pumps with SMART™

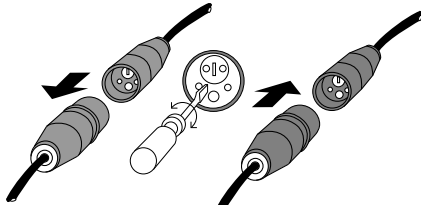
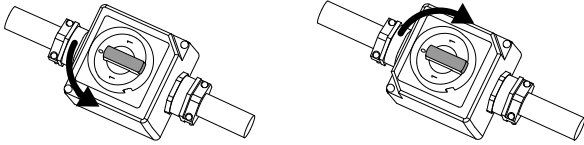
Cause	Remedy
<p>The phase sequence may be incorrect.</p>	<ol style="list-style-type: none"> 1. Pull out the plug. 2. Do one of the following: <ul style="list-style-type: none"> • Shift two phases by turning two contact pins with a screwdriver. <hr/> <p>NOTICE: Do not take the plug apart.</p> <hr/>  <p>Figure 9: CEE plug</p> <ul style="list-style-type: none"> • Turn the knob to the opposite position 1, with 8 seconds delay. <hr/> <p>NOTICE: Do not reverse the phase sequence while the motor is running. Doing so may cause incorrect rotation resulting in damages to the motor electronics and the rotating parts. Respect the 8 seconds delay.</p> <hr/>  <p>Figure 10: Phase shifter On/Off switch</p> <ul style="list-style-type: none"> • If no glove or phase shifter is used, then shift two phase conductors in the cabinet.

If the problem persists, contact the local Grindex service shop. Always state the product number and the serial number of your pump when you contact Grindex, see [Product Description](#) (page 11).

The pump does not start



WARNING:

Always disconnect and lock out power before servicing to prevent unexpected startup. Failure to do so could result in death or serious injury.

NOTICE:

Do NOT override the motor protection repeatedly if it has tripped. Doing so may result in equipment damage.

Cause	Remedy
An alarm signal has been triggered on the control panel.	Check that: <ul style="list-style-type: none"> • The impeller rotates freely. • The sensor indicators do not indicate an alarm. • The overload protection is not tripped. If the problem still persists: Contact the local Grindex service shop.
The pump does not start automatically, but can be started manually.	Check that: <ul style="list-style-type: none"> • The start level regulator is functioning. Clean or replace if necessary. • All connections are intact. • The relay and contactor coils are intact. • The control switch (Man/Auto) makes contact in both positions. Check the control circuit and functions.
The installation is not receiving voltage.	Check that: <ul style="list-style-type: none"> • The main power switch is on. • There is control voltage to the start equipment. • The fuses are intact. • There is voltage in all phases of the supply line. • All fuses have power and that they are securely fastened to the fuse holders. • The overload protection is not tripped. • The motor cable is not damaged.
The impeller is stuck.	Clean: <ul style="list-style-type: none"> • The impeller • The sump in order to prevent the impeller from clogging again.

If the problem persists, contact the local Grindex service shop. Always state the product number and the serial number of your pump when you contact Grindex, see [Product Description](#) (page 11).

The pump does not stop when a level sensor is used



WARNING:

Always disconnect and lock out power before servicing to prevent unexpected startup. Failure to do so could result in death or serious injury.

Cause	Remedy
The pump is unable to empty the sump to the stop level.	Check that: <ul style="list-style-type: none"> • There are no leaks from the piping and/or discharge connection. • The impeller is not clogged. • The non-return valve(s) are functioning properly. • The pump has adequate capacity. For information: Contact the local Grindex service shop.
There is a malfunction in the level-sensing equipment.	<ul style="list-style-type: none"> • Clean the level regulators. • Check the functioning of the level regulators. • Check the contactor and the control circuit. • Replace all defective items.
The stop level is set too low.	Raise the stop level.

If the problem persists, contact the local Grindex service shop. Always state the product number and the serial number of your pump when you contact Grindex, see [Product Description](#) (page 11).

The pump starts-stops-starts in rapid sequence

Cause	Remedy
The pump starts due to back-flow which fills the sump to the start level again.	Check that: <ul style="list-style-type: none"> • The distance between the start and stop levels is sufficient. • The non-return valve(s) work(s) properly. • The length of the discharge pipe between the pump and the first non-return valve is sufficiently short.
The self-holding function of the contactor malfunctions.	Check: <ul style="list-style-type: none"> • The contactor connections. • The voltage in the control circuit in relation to the rated voltages on the coil. • The functioning of the stop-level regulator. • Whether the voltage drop in the line at the starting surge causes the contactor's self-holding malfunction.

If the problem persists, contact the local Grindex service shop. Always state the product number and the serial number of your pump when you contact Grindex, see [Product Description](#) (page 11).

The pump runs but the motor protection trips



WARNING:

Always disconnect and lock out power before servicing to prevent unexpected startup. Failure to do so could result in death or serious injury.

NOTICE:

Do NOT override the motor protection repeatedly if it has tripped. Doing so may result in equipment damage.

Cause	Remedy
The motor protection is set too low.	Set the motor protection according to the data plate and if applicable the cable chart.
The impeller is difficult to rotate by hand.	<ul style="list-style-type: none"> • Clean the impeller. • Clean out the sump. • Check that the impeller is properly trimmed.
The drive unit is not receiving full voltage on all three phases.	<ul style="list-style-type: none"> • Check the fuses. Replace fuses that have tripped. • If the fuses are intact, notify a certified electrician.
The phase currents vary, or they are too high.	Contact the local Grindex service shop.
The insulation between the phases and ground in the stator is defective.	<ol style="list-style-type: none"> 1. Use an insulation tester. With a 1000 V DC megger, check that the insulation between the phases and between any phase and ground is > 5 megohms. 2. If the insulation is less: Contact the local Grindex service shop.
The density of the pumped fluid is too high.	<p>Make sure that the maximum density is 1100 kg/m³ (9.2 lb/US gal)</p> <ul style="list-style-type: none"> • Change to a more suitable pump. • Contact the local Grindex service shop.
The ambient temperature exceeds the maximum ambient temperature.	The pump must not be used for such an application.
There is a malfunction in the overload protection.	Replace the overload protection.
The SMART™ motor protection may need to be reset.	<p>Try one of the following:</p> <ul style="list-style-type: none"> • Reset the SMART™ motor protection by pulling and reinserting the power plug. • Or, disconnect and reconnect the power. <div style="text-align: center;"> </div>

Cause	Remedy
	<div style="display: flex; align-items: center;">  <p>WARNING: The pump will restart automatically after a corrected phase fault or power cut.</p> </div>

If the problem persists, contact the local Grindex service shop. Always state the product number and the serial number of your pump when you contact Grindex, see [Product Description](#) (page 11).

The pump delivers too little or no water



WARNING:

Always disconnect and lock out power before servicing to prevent unexpected startup. Failure to do so could result in death or serious injury.

NOTICE:

Do NOT override the motor protection repeatedly if it has tripped. Doing so may result in equipment damage.

Cause	Remedy
The impeller rotates in the wrong direction.	<ul style="list-style-type: none"> • If it is a 3-phase pump without SMART™, transpose two phase leads. • If it is a 3-phase pump with SMART™, correct the internal wiring. • If it is a 1-phase pump: Contact the local Grindex service shop.
One or more of the valves are set in the wrong positions.	<ul style="list-style-type: none"> • Reset the valves that are set in the wrong position. • Replace the valves, if necessary. • Check that all valves are correctly installed according to media flow. • Check that all valves open correctly.
The impeller is difficult to rotate by hand.	<ul style="list-style-type: none"> • Clean the impeller. • Clean out the sump. • Check that the impeller is properly trimmed.
The pipes are obstructed.	Clean out the pipes to ensure a free flow.
The pipes and joints leak.	Find the leaks and seal them.
There are signs of wear on the impeller, pump, and casing.	Replace the worn parts.
The liquid level is too low.	<ul style="list-style-type: none"> • Check that the level sensor is set correctly. • Depending on the installation type, add a means for priming the pump, such as a foot valve.

If the problem persists, contact the local Grindex service shop. Always state the product number and the serial number of your pump when you contact Grindex, see [Product Description](#) (page 11).

Technical Reference

Application limits

Data	Description
Media (liquid) temperature	Maximum temperature 40°C (104°F)
pH of the pumped media (liquid)	5–8
Media (liquid) density	Maximum density: 1100 kg/m ³ (9.2 lb. per US gal.)
Depth of immersion	20 m (65 ft.)
Other	For specific weight, current, voltage, power rating, and speed of the pump, see the data plate on the pump. For starting current, see Motor data (page 48). For other applications, contact the nearest Grindex representative for information.

Motor data

Feature	Description
Motor type	Squirrel-cage induction motor
Frequency	Standard version: 50 or 60 Hz MSHA version: 60 Hz
Supply	1-phase or 3-phase
Starting method	Direct on-line
Maximum starts per hour	30 evenly spaced starts per hour
Code compliance	IEC 60034-1
Rated output variation	±10%
Voltage variation without overheating	±10%, provided that it does not run continuously at full load
Voltage imbalance tolerance	2%
Maximum frequency variation (for pumps with SMART™)	±3 Hz
Stator insulation class	F (155°C [310°F])

Specific motor data, standard version

1-phase, 50 Hz

Motor type:

- 2,755 rpm
- Rated output 0.85 kW (1.15 hp)
- Maximum power consumption 1.1 kW (1.5 hp)

Voltage (V)	Rated current (A)	Starting current (A)
110	11	38
220	5.3	19
230	5.1	20
240	5.1	21

Motor type:

- 2,870 rpm
- Rated output 1.4 kW (1.9 hp)
- Maximum power consumption 1.8 kW (2.4 hp)

Voltage (V)	Rated current (A)	Starting current (A)
220	8.0	31
230	7.8	32
240	7.8	34

3-phase, 50 Hz

Motor type:

- 2,740 rpm
- Rated output 1.2 kW (1.6 hp)
- Maximum power consumption 1.6 kW (2.1 hp)

Voltage (V)	Rated current (A)	Starting current (A)
220 D	4.8	20
230 D	4.7	21
380 Y	2.8	12
400 Y	2.7	12
415 Y	2.7	13
500 Y	2.1	9
550 Y	2.1	10

1-phase, 60 Hz

Motor type:

- 3,410 rpm
- Rated output 0.97 kW (1.3 hp)
- Maximum power consumption 1.3 kW (1.8 hp)

Voltage (V)	Rated current (A)	Starting current (A)
115	11	49
220	5.8	23
230	5.6	24
240	5.6	25

Motor type:

- 3,460 rpm
- Rated output 1.5 kW (2.0 hp)
- Maximum power consumption 1.8 kW (2.4 hp)

Voltage (V)	Rated current (A)	Starting current (A)
220	8.4	35
230	8.2	37
240	8.2	39

3-phase, 60 Hz

Motor type:

- 3,355 rpm
- Rated output 1.4 kW (1.9 hp)
- Maximum power consumption 1.8 kW (2.4 hp)

Voltage (V)	Rated current (A)	Starting current (A)
220 D	5.5	29
220 D parallel	5.3	26
230 Y parallel	5.2	27
230 D parallel	5.1	27
240 D parallel	5.1	29
380 Y	3.2	17
380 Y parallel	3.1	15
440 D serial	2.7	13
460 Y serial	2.6	14
460 D serial	2.6	14
480 Y serial	2.6	14
575 Y	2.1	9.9
600 Y	2.0	10

Specific motor data, MSHA version

1-phase, 60 Hz

Motor type:

- 3,300 rpm
- Rated output 1.3 kW (1.8 hp)
- Maximum power consumption 1.6 kW (2.1 hp)

Voltage (V)	Rated current (A)	Starting current (A)
115 parallel	15	74
220 serial	7.5	35
230 serial	7.4	37
240 serial	7.5	39

3-phase, 60 Hz

Motor type:

- 3,300 rpm
- Rated output 1.4 kW (1.9 hp)
- Maximum power consumption 1.8 kW (2.4 hp)

Voltage (V)	Rated current (A)	Starting current (A)
460 Y serial	2.6	13
480 Y serial	2.6	14
575 Y serial	2.1	9.6
600 Y serial	2.0	10

Dimensions and weights

All measurements in the illustrations are in millimeters, if not otherwise specified.

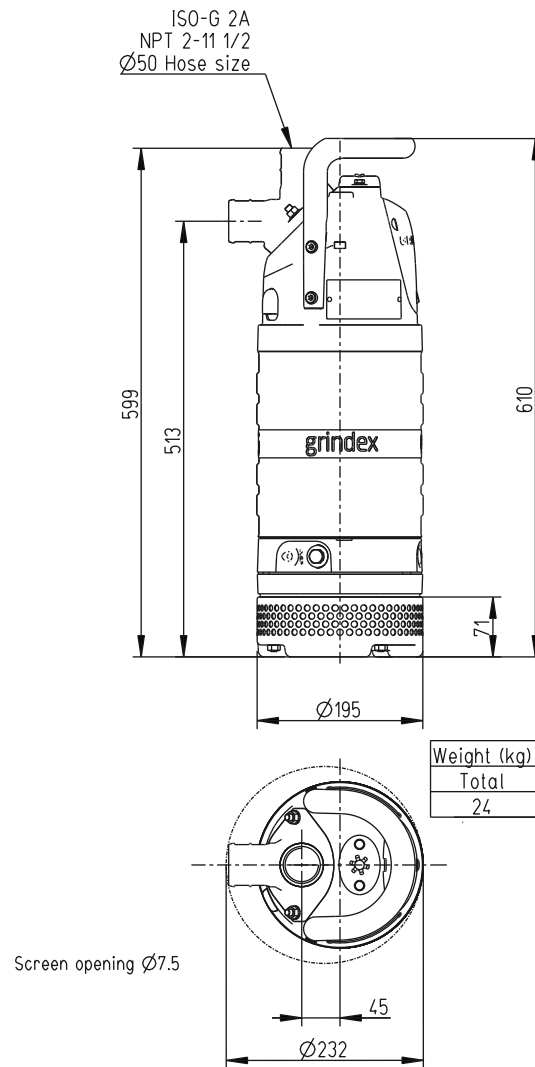

Figure 11: Standard version, 1-phase (50/60 Hz), 1.8 kW motor

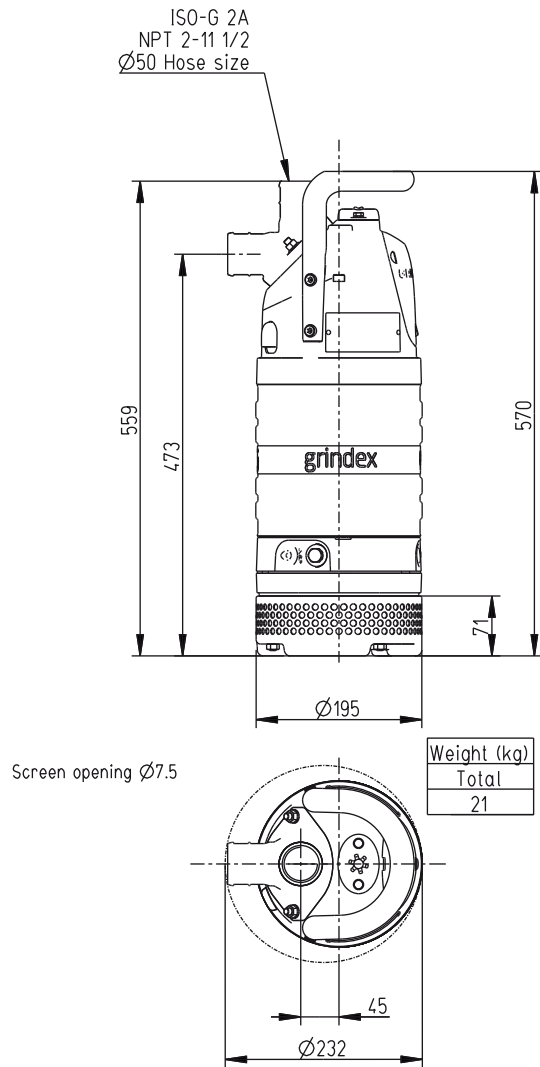
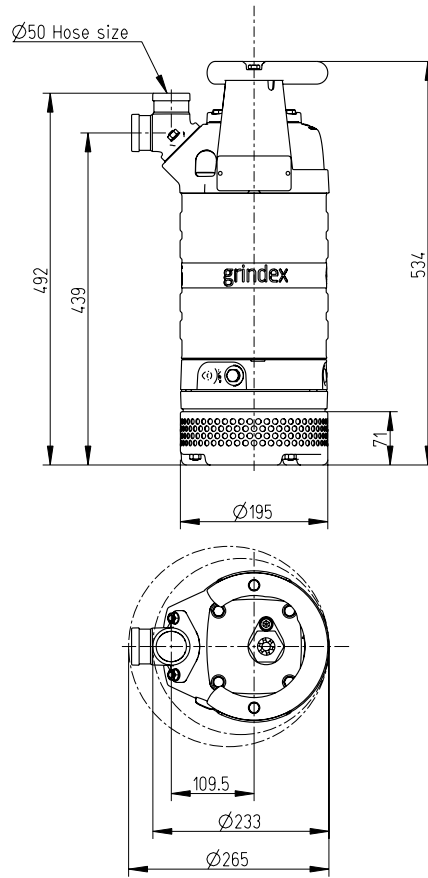

Figure 12: Standard version, all other motors



Screen opening $\varnothing 7.5$

Weight (kg)
Total
24

Figure 13: MSHA version, 1-phase (60 Hz), 1.6 kW motor

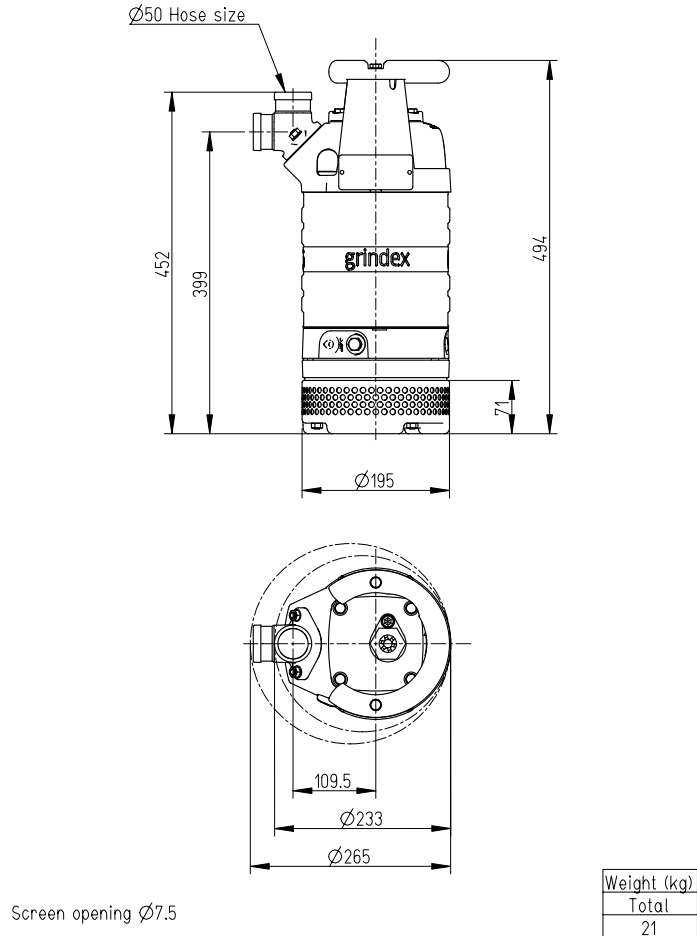

Figure 14: MSHA version, all other motors

Performance curves

Test standard

Pumps are tested in accordance with ISO 9906, HI level A.

Standard pump version, 50 Hz

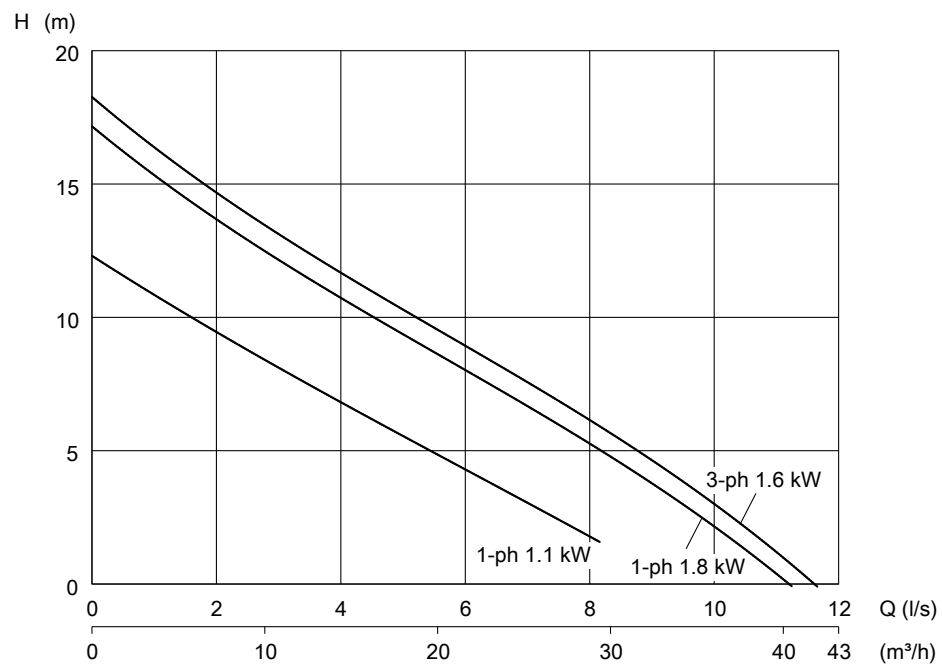
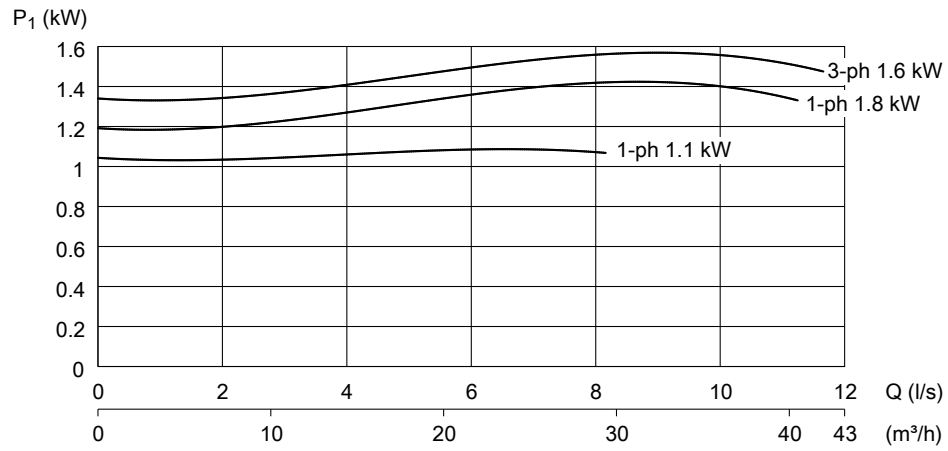

Standard pump version, 60 Hz

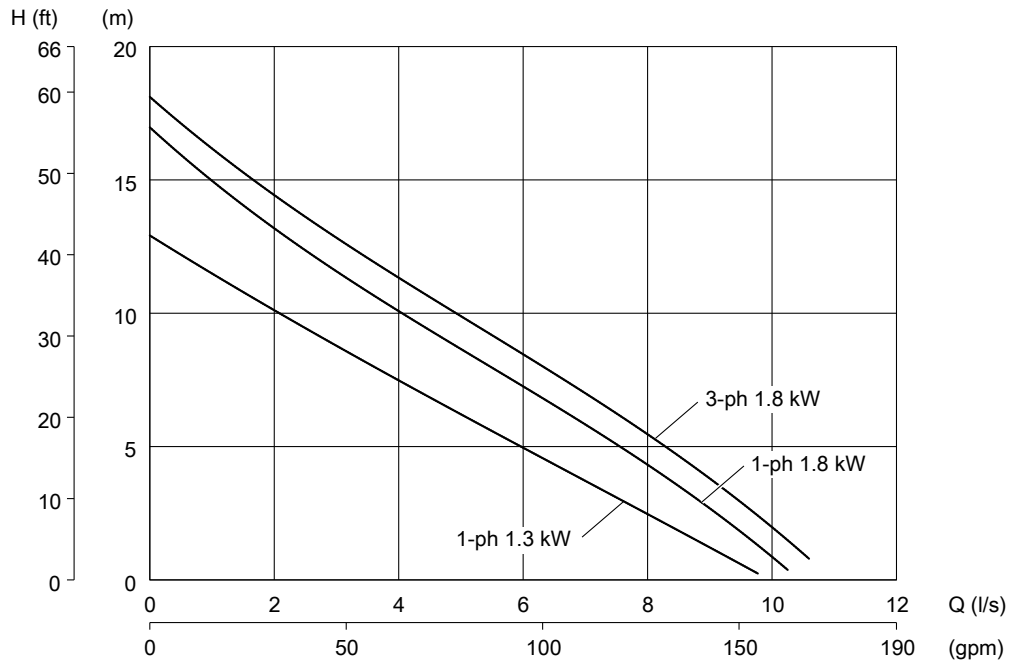
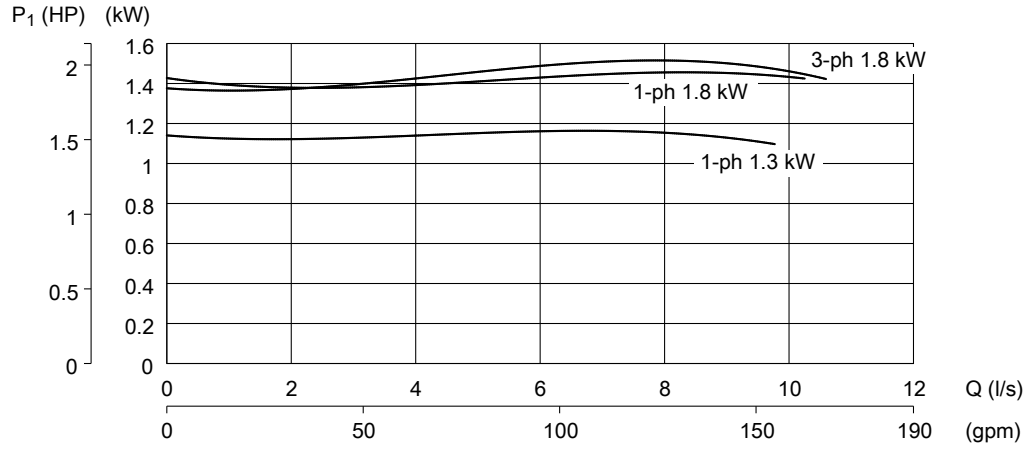

MSHA pump version, 60 Hz

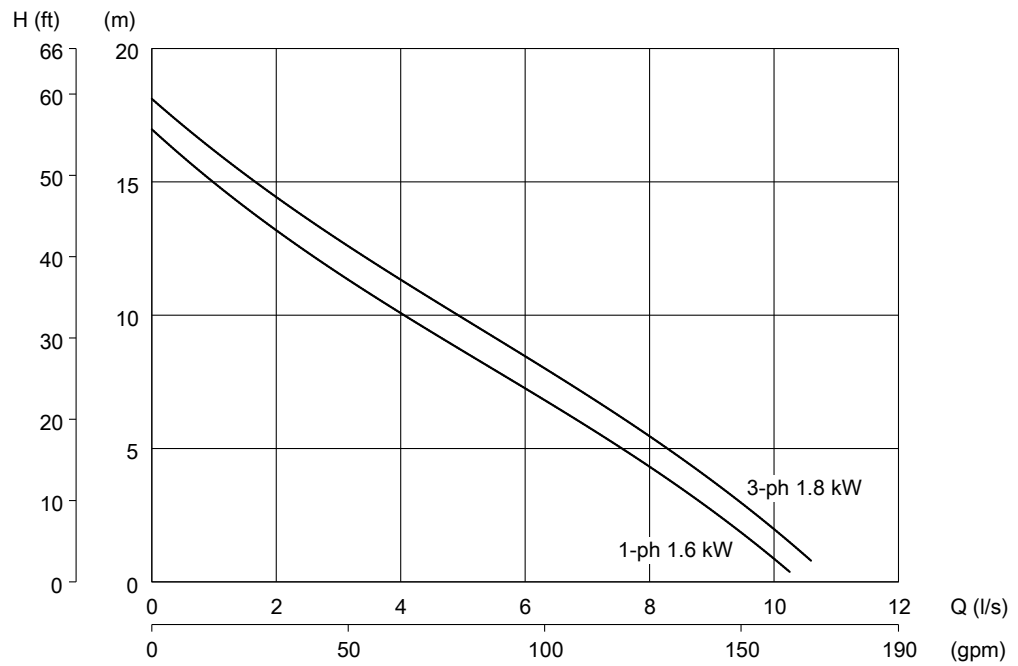
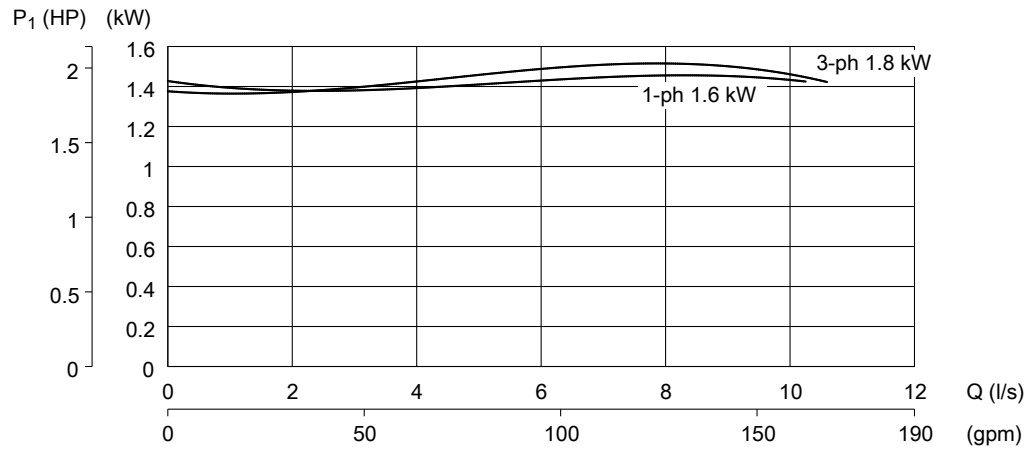



Grindex
Gesällvägen 33
174 87 Sundbyberg
Sweden
Tel. +46-8-606 66 00
Fax +46-8-745 53 28