

Installation, Operation, and Maintenance Manual

8105.082/182 Master



Table of Contents

Introduction and Safety	3
Introduction.....	3
Safety terminology and symbols.....	3
Product warranty.....	4
Safety.....	5
User safety.....	5
Environmental safety.....	7
Transportation and Storage	8
Inspect the delivery.....	8
Inspect the package.....	8
Inspect the unit.....	8
Transportation guidelines.....	8
Lifting.....	8
Temperature ranges for transportation, handling and storage.....	9
Storage guidelines.....	9
Product Description	10
Pump design.....	10
Monitoring equipment.....	10
The data plate.....	11
Installation	13
Install the pump.....	13
Install.....	14
Make the electrical connections.....	15
Connect the motor cable to the pump.....	17
Cable charts.....	17
Cable charts, MSHA version.....	21
Check the impeller rotation: Pumps without built-in motor protection.....	21
Check the phase sequence: Pumps with built-in motor protection.....	22
Operation	25
Start the pump.....	25
Clean the pump.....	26
Maintenance	27
Torque values.....	28
Service.....	29
Inspection.....	29
Major overhaul.....	31
Change the oil.....	31
Replace the impeller.....	32
Remove the impeller N, H.....	32
Remove the impeller SH.....	34
Install the impeller N, H.....	36
Install the impeller SH.....	39
Troubleshooting	46
The pump does not start, for pumps with SMART™ or softstarter.....	47

The pump does not start.....	47
The pump does not stop when a level sensor is used.....	48
The pump starts-stops-starts in rapid sequence.....	49
The pump runs but the motor protection trips.....	49
The pump delivers too little or no water.....	50
The pump does not start when a softstarter is used.....	51
Technical Reference.....	54
Application limits.....	54
Specific motor data, standard version.....	55
Specific motor data, MSHA version.....	56
Dimensions and weights.....	56
Performance curves.....	64

Introduction and Safety

Introduction

Purpose of this manual

The purpose of this manual is to provide necessary information for:

- Installation
- Operation
- Maintenance



CAUTION:

Read this manual carefully before installing and using the product. Improper use of the product can cause personal injury and damage to property, and may void the warranty.

NOTICE:

Save this manual for future reference, and keep it readily available at the location of the unit.



Safety terminology and symbols

About safety messages

It is extremely important that you read, understand, and follow the safety messages and regulations carefully before handling the product. They are published to help prevent these hazards:

- Personal accidents and health problems
- Damage to the product
- Product malfunction

Hazard levels

Hazard level	Indication
 DANGER:	A hazardous situation which, if not avoided, will result in death or serious injury
 WARNING:	A hazardous situation which, if not avoided, could result in death or serious injury
 CAUTION:	A hazardous situation which, if not avoided, could result in minor or moderate injury
NOTICE:	<ul style="list-style-type: none"> • A potential situation which, if not avoided, could result in undesirable conditions • A practice not related to personal injury

Hazard categories

Hazard categories can either fall under hazard levels or let specific symbols replace the ordinary hazard level symbols.

Electrical hazards are indicated by the following specific symbol:



Electrical Hazard:

These are examples of other categories that can occur. They fall under the ordinary hazard levels and may use complementing symbols:

- Crush hazard
- Cutting hazard
- Arc flash hazard

Product warranty

Coverage

Grindex undertakes to remedy the following faults in products sold by Grindex under the following conditions:

- The faults are due to defects in design, materials or workmanship.
- The faults are reported to an Grindex representative within the warranty period.
- The product is used only under the conditions described in this manual.
- The monitoring equipment incorporated in the product is correctly connected and in use.
- All service and repair work is done by personnel authorized by Grindex.
- Genuine Grindex parts are used.

Limitations

The warranty does not cover faults caused by the following:

- Deficient maintenance
- Improper installation
- Modifications or changes to the product and installation carried out without consulting Grindex
- Incorrectly executed repair work
- Normal wear and tear

Grindex assumes no liability for the following:

- Bodily injuries
- Material damages
- Economic losses

Warranty claim

Grindex products are high-quality products with expected reliable operation and long life. However, should the need arise for a warranty claim, please contact your Grindex representative.

Spare parts

Grindex guarantees that spare parts will be available for 10 years after the manufacture of this product has been discontinued.

Safety



WARNING:

- The operator must be aware of safety precautions to prevent physical injury.
 - Any pressure-containing device can explode, rupture, or discharge its contents if it is over-pressurized. Take all necessary measures to avoid over-pressurization.
 - Operating, installing, or maintaining the unit in any way that is not covered in this manual could cause death, serious personal injury, or damage to the equipment. This includes any modification to the equipment or use of parts not provided by Grindex. If there is a question regarding the intended use of the equipment, please contact an Grindex representative before proceeding.
 - This manual clearly identifies accepted methods for disassembling units. These methods must be adhered to. Trapped liquid can rapidly expand and result in a violent explosion and injury. Never apply heat to impellers, propellers, or their retaining devices to aid in their removal.
 - Do not change the service application without the approval of an authorized Grindex representative.
-



CAUTION:

You must observe the instructions contained in this manual. Failure to do so could result in physical injury, damage, or delays.

User safety

General safety rules

These safety rules apply:

- Always keep the work area clean.
- Pay attention to the risks presented by gas and vapors in the work area.
- Avoid all electrical dangers. Pay attention to the risks of electric shock or arc flash hazards.
- Always bear in mind the risk of drowning, electrical accidents, and burn injuries.

Safety equipment

Use safety equipment according to the company regulations. Use this safety equipment within the work area:

- Hard hat
- Safety goggles, preferably with side shields
- Protective shoes
- Protective gloves
- Gas mask
- Hearing protection
- First-aid kit
- Safety devices

NOTICE:

Never operate a unit unless safety devices are installed. Also see specific information about safety devices in other chapters of this manual.

Electrical connections

Electrical connections must be made by certified electricians in compliance with all international, national, state, and local regulations. For more information about requirements, see sections dealing specifically with electrical connections.

Hazardous liquids

The product is designed for use in liquids that can be hazardous to your health. Observe these rules when you work with the product:

- Make sure that all personnel who work with biologically hazardous liquids are vaccinated against diseases to which they may be exposed.
- Observe strict personal cleanliness.

Wash the skin and eyes

Follow these procedures for chemicals or hazardous fluids that have come into contact with your eyes or your skin:

Condition	Action
Chemicals or hazardous fluids in eyes	<ol style="list-style-type: none"> 1. Hold your eyelids apart forcibly with your fingers. 2. Rinse the eyes with eyewash or running water for at least 15 minutes. 3. Seek medical attention.
Chemicals or hazardous fluids on skin	<ol style="list-style-type: none"> 1. Remove contaminated clothing. 2. Wash the skin with soap and water for at least 1 minute. 3. Seek medical attention, if necessary.

MSHA requirements

According to the United States of America's Code of Federal Regulations, the following requirements must be fulfilled to maintain Mine Safety and Health Administration (MSHA) permissibility of this equipment:

Subject area	Requirements
General safety	<ul style="list-style-type: none"> • Frequent inspections must be made. • All electrical parts, portable cable, and wiring must be kept in a safe condition. • There must not be any openings into the casings of the electrical parts. • The machine frame must be effectively earthed (grounded). • Power wires must not be used for earthing (grounding). • The operating voltage must match the voltage rating of the motor.

Subject area	Requirements
Service and repair	<ul style="list-style-type: none"> • Inspections, service, and repairs are only allowed when the portable cable is disconnected from the power supply. • Work must be performed by trained personnel (preferably the manufacturer or agent) to ensure that the pump is restored to its original state of safety in regards to all flame-arresting paths. • Replacement parts must be exactly equal to those provided by the manufacturer. • When cable entries are disturbed on pump or control, they must be reassembled in the approved manner. <div style="display: flex; align-items: center; margin-top: 10px;">  <div> <p>DANGER:</p> <p>Failure to restore the permissible equipment to its original state of safety will void the MSHA approval. The creation of a safety hazard will subject the owner / operator of a mine to citations and penalties under the law.</p> </div> </div>
Fastenings	All bolts, nuts, screws, and threaded covers must be properly tightened and secured.
Cables	A flame-resistant portable cable must be used. It has to bear an MSHA-assigned identification number and be adequately protected by an automatic circuit-interrupting device. Special care must be taken in handling the cable to avoid mechanical damage and wear.
Operation	Polyurethane-equipped products must not be operated dry in hazardous areas.

Environmental safety

The work area

Always keep the station clean to avoid and/or discover emissions.

Waste and emissions regulations

Observe these safety regulations regarding waste and emissions:

- Dispose appropriately of all waste.
- Handle and dispose of the processed liquid in compliance with applicable environmental regulations.
- Clean up all spills in accordance with safety and environmental procedures.
- Report all environmental emissions to the appropriate authorities.

Electrical installation

For electrical installation recycling requirements, consult your local electric utility.

Recycling guidelines

Always recycle according to the guidelines listed below:

1. Follow local laws and regulations regarding recycling if the unit or parts are accepted by an authorized recycling company.
2. If the first guideline is not applicable, then return the unit or parts to the nearest Grindex representative.

Transportation and Storage

Inspect the delivery

Inspect the package

1. Inspect the package for damaged or missing items upon delivery.
2. Note any damaged or missing items on the receipt and freight bill.
3. File a claim with the shipping company if anything is out of order.
If the product has been picked up at a distributor, make a claim directly to the distributor.

Inspect the unit

1. Remove packing materials from the product.
Dispose of all packing materials in accordance with local regulations.
2. Inspect the product to determine if any parts have been damaged or are missing.
3. If applicable, unfasten the product by removing any screws, bolts, or straps.
For your personal safety, be careful when you handle nails and straps.
4. Contact the local sales representative if there is any issue.

Transportation guidelines

Precautions



DANGER:

Disconnect and lock out electrical power before installing or servicing the unit.



WARNING:

- Stay clear of suspended loads.
 - Observe accident prevention regulations in force.
-

Position and fastening

The unit can be transported either horizontally or vertically. Make sure that the unit is securely fastened during transportation, and cannot roll or fall over.

Lifting



WARNING:

Crush Hazard.

- Always lift the unit by its designated lifting points.
 - Use suitable lifting equipment and ensure that the product is properly harnessed.
 - Wear personal protective equipment.
 - Stay clear of cables and suspended loads.
-

Lifting equipment and tackle should always be inspected before starting work.

Temperature ranges for transportation, handling and storage

Handling at freezing temperature

At temperatures below freezing, the product and all installation equipment, including the lifting gear, must be handled with extreme care.

Make sure that the product is warmed up to a temperature above the freezing point before starting up. Avoid rotating the impeller/propeller by hand at temperatures below the freezing point. The recommended method to warm the unit up is to submerge it in the liquid which will be pumped or mixed.

NOTICE:

Never use a naked flame to thaw the unit.

Unit in as-delivered condition

If the unit is still in the condition in which it left the factory - all packing materials are undisturbed - then the acceptable temperature range during transportation, handling and storage is: -50°C (-58°F) to $+60^{\circ}\text{C}$ ($+140^{\circ}\text{F}$).

If the unit has been exposed to freezing temperatures, then allow it to reach the ambient temperature of the sump before operating.

Lifting the unit out of liquid

The unit is normally protected from freezing while operating or immersed in liquid, but the impeller/propeller and the shaft seal may freeze if the unit is lifted out of the liquid into a surrounding temperature below freezing.

Units equipped with an internal cooling system are filled with a mixture of water and 30% glycol. This mixture remains a flowing liquid at temperatures down to -13°C (9°F). Below -13°C (9°F), the viscosity increases such that the glycol mixture will lose its flow properties. However, the glycol-water mixture will not solidify completely and thus cannot harm the product.

Follow these guidelines to avoid freezing damage:

1. Empty all pumped liquid, if applicable.
2. Check all liquids used for lubrication or cooling, both oil and water-glycol mixtures, for the presence of water. Change if needed.

Storage guidelines

Storage location

The product must be stored in a covered and dry location free from heat, dirt, and vibrations.

NOTICE:

- Protect the product against humidity, heat sources, and mechanical damage.
 - Do not place heavy weights on the packed product.
-

Long-term storage

If the unit is stored more than six months, then the following apply:

- Before operating the unit after storage, it must be inspected with special attention to the seals and the cable entry.
- The impeller/propeller must be rotated every other month to prevent the seals from sticking together.

Product Description

Products included

Pump model	Approvals
Master 8105.182	Standard
Master 8105.082	

Pump design

The pump is submersible, and driven by an electric motor.

Intended use

The product is intended for moving waste water, sludge, raw and clean water. Always follow the limits given in [Application limits](#) (page 54). If there is a question regarding the intended use of the equipment, please contact a Grindex representative before proceeding.



WARNING:

In explosive or flammable environments, only use Ex- or MSHA-approved products.

NOTICE:

Do NOT use the pump in highly corrosive liquids.

For information about pH, see [Application limits](#) (page 54).

Particle size

The pump can handle liquid containing particles that correspond to the holes in the strainer.

Number of holes	Hole dimensions
360	Diameter 10.0 mm (0.39 in)

For more information about the strainer, see [Dimensions and weights](#) (page 56).

Pressure class

N	Medium head
H	High head
SH	Super head

Impeller type

Wear resistant

Monitoring equipment

The following applies to the monitoring equipment of the pump:

- The stator incorporates thermal contacts connected in series that activate the alarm at overtemperature.
- The thermal contacts open at 140°C (284°F) and close at 105°C (221°F).

The data plate

Introduction

The data plate is a metal label located on the main body of the pump. The data plate lists key product specifications.

The data plate

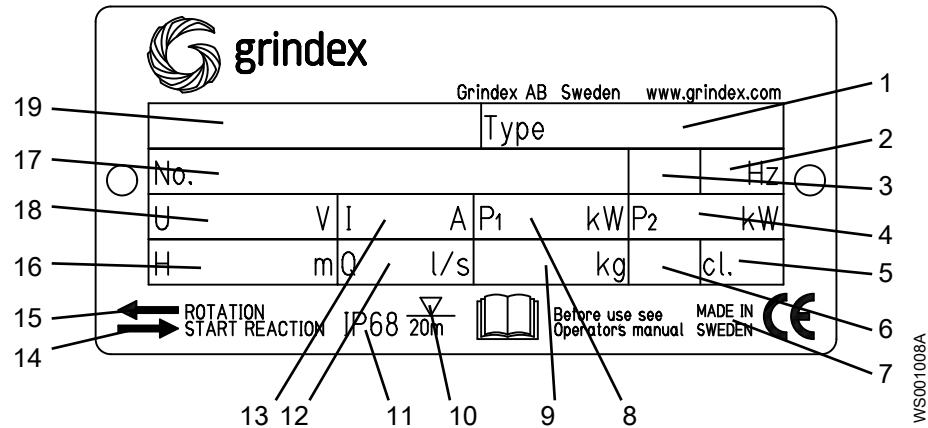

1. Pump type number
2. Frequency
3. Phases, type of current
4. Rated shaft power
5. Thermal class
6. Locked rotor code-letter
7. Country of origin
8. Maximum power consumption
9. Product weight
10. Maximum submersion depth
11. Degree of protection
12. Maximum capacity
13. Rated current
14. Direction of the start reaction
15. Direction of the impeller rotation
16. Maximum head
17. Serial number
18. Rated voltage
19. Pump model

Warning plate

Pumps without built-in motor protection have an additional data plate.

This pump must be used with separate overload protection in accordance with technical data.



The MSHA approval plate

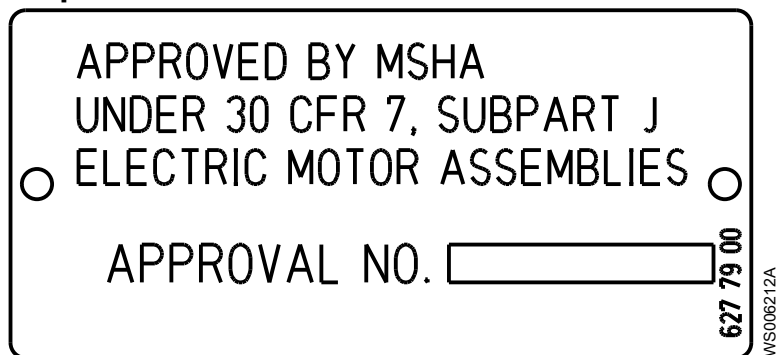

Installation

Install the pump



DANGER:

Disconnect and lock out electrical power before installing or servicing the unit.



WARNING:

- Do not install the starter equipment in an explosive zone unless it is explosion-proof rated.
 - Do not install CSA-approved products in locations that are classified as hazardous in the national electric code, ANSI/NFPA 70-2005.
 - Vent the tank of a sewage station in accordance with local plumbing codes.
 - Make sure that the unit cannot roll or fall over and injure people or damage property.
-



WARNING:

Electrical shock hazard. Check that the cable and cable entry have not been damaged during transport before installing the pump.

NOTICE:

- Never force piping to make a connection with a pump.
-

These requirements apply:

- Use the pump dimensional drawing in order to ensure proper installation.
- Provide a suitable barrier around the work area, for example, a guard rail.
- Check the explosion risk before you weld or use electric hand tools.
- Remove all debris from the inlet piping system before you install the pump.
- Always check the impeller rotation before lowering the pump into the pumped liquid.

Sedimentation prevention

In order to avoid sedimentation when the pumped liquid contains solid particles, the velocity of the liquid in the discharge line must exceed a certain value. Choose applicable minimum velocity from the table, and choose proper dimension of the discharge line accordingly.

Mixture	Minimum velocity, meter per second (feet per second)
Water + coarse gravel	4 (13)
Water + gravel	3.5 (11)
Water + sand, particle size <0.6 mm (0.024 in)	2.5 (8.2)
Water + sand, particle size <0.1 mm (0.004 in)	1.5 (4.9)

For more permanent installations with a heavily contaminated pumped liquid, a settling pump-sump is recommended.

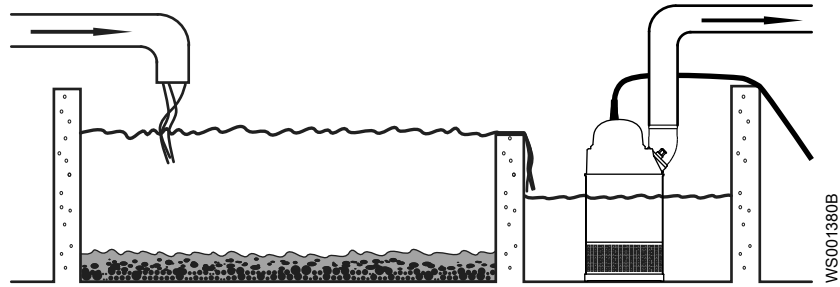
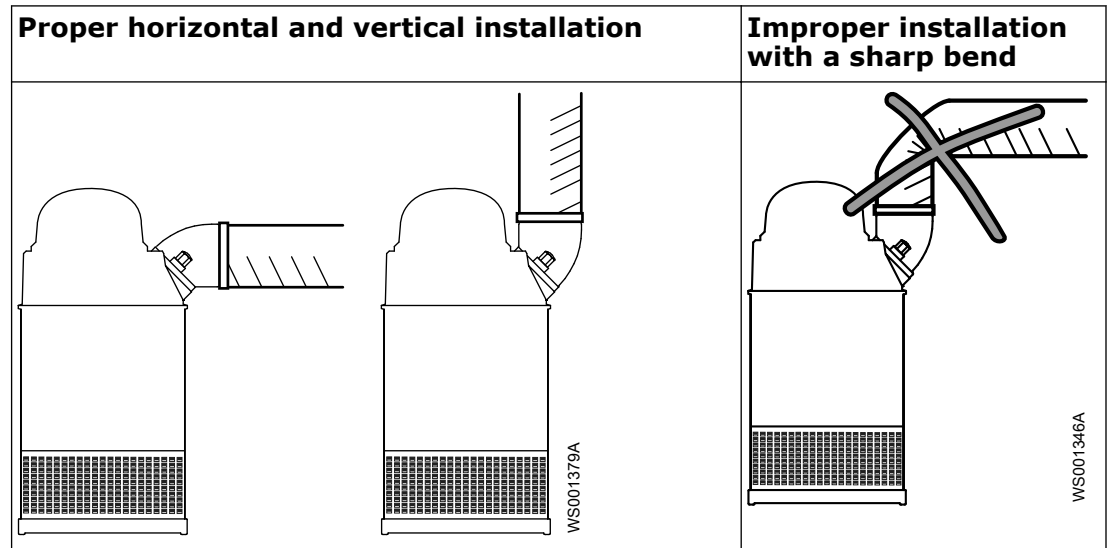

Figure 1: Settling pump-sump

Discharge line requirements

The discharge line can be run vertically or horizontally, but must be without sharp bends.



Fasteners



WARNING:

- Only use fasteners of the proper size and material.
- Replace all corroded fasteners.
- Make sure that all fasteners are properly tightened and that there are no missing fasteners.

Install

The pump is transportable and intended to operate either completely or partially submerged in the pumped liquid. The pump is equipped with a connection for hose or pipe.

These requirements and instructions only apply when the installation is made according to the dimensional drawing.

1. Run the cable so that it has no sharp bends, is not pinched, and cannot be sucked into the pump inlet.
2. Connect the discharge line.

The discharge line can be run vertically or horizontally, but must be without sharp bends.

3. Lower the pump into the sump.

The cable must not be used for this purpose. You should attach a rope or similar to the handle or the eyebolts for lowering and lifting the pump.

Heavier pumps must be lifted and lowered down by crane. Suspend the pump by the lifting handle or the eyebolts with chains or wires.

4. Place the pump on the base and make sure it cannot fall over or sink. The base should consist of a plank, a bed of coarse gravel, or a cut-down and perforated oil drum.

Alternatively, the pump can be suspended with a lifting chain just above the sump bottom. Make sure that the pump cannot rotate at startup or during operation.

5. Connect the motor cable and the starter and monitoring equipment according to the separate instructions.

Master MSHA: Make sure that the impeller rotation is correct. For more information, see [Check the impeller rotation: Pumps without built-in motor protection](#) (page 21).

Master: Make sure that the phase sequence is correct. For more information, see [Check the phase sequence: Pumps with built-in motor protection](#) (page 22).

Make the electrical connections

General precautions



Electrical Hazard:

- A certified electrician must supervise all electrical work. Comply with all local codes and regulations.
- Before starting work on the unit, make sure that the unit and the control panel are isolated from the power supply and cannot be energized. This applies to the control circuit as well.
- Leakage into the electrical parts can cause damaged equipment or a blown fuse. Keep the end of the motor cable above the liquid level.
- Make sure that all unused conductors are insulated.
- There is a risk of electrical shock or explosion if the electrical connections are not correctly carried out or if there is fault or damage on the product.



WARNING:

Do not install the starter equipment in an explosive zone unless it is explosion-proof rated.



CAUTION:

If the pump is equipped with automatic level control and/or internal contactor, there is a risk of sudden restart.

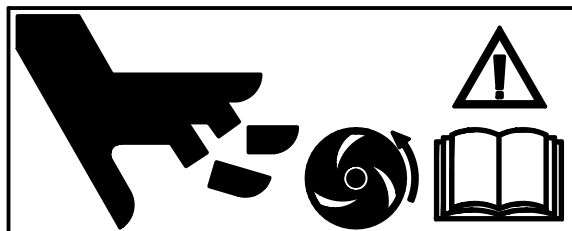

WS006209A

Requirements

These general requirements apply for electrical installation:

- The supply authority must be notified before installing the pump if it will be connected to the public mains. When the pump is connected to the public power supply, it may cause flickering of incandescent lamps when started.
- The mains voltage and frequency must agree with the specifications on the data plate. If the pump can be connected to different voltages, then the connected voltage is specified by a yellow sticker close to the cable entry.
- The fuses and circuit breakers must have the proper rating, and the pump overload protection (motor protection breaker) must be connected and set to the rated current according to the data plate and if applicable the cable chart. The starting current in direct-on-line start can be up to six times higher than the rated current.
- The fuse rating and the cables must be in accordance with the local rules and regulations.
- If the rated current of the pump is the same or close to the ampere rating of the fuses and circuit breakers, then the fuses and circuit breakers are required to have characteristics for motors.
- If intermittent operation is prescribed, then the pump must be provided with monitoring equipment supporting such operation.
- The thermal contacts/thermistors must be in use.

Cables

These are the requirements to follow when you install cables:

- The cables must be in good condition, not have any sharp bends, and not be pinched.
- The sheathing must not be damaged and must not have indentations or be embossed (with markings, etc.) at the cable entry.
- The cable entry seal sleeve and washers must conform to the outside diameter of the cable.
- The minimum bending radius must not be below the accepted value.
- If using a cable which has been used before, a short piece must be peeled off when refitting it so that the cable entry seal sleeve does not close around the cable at the same point again. If the outer sheath of the cable is damaged, then replace the cable. Contact a Grindex service shop.
- The voltage drop in long cables must be taken into account. The drive unit's rated voltage is the voltage measured at the cable connection point in the pump.
- The screened cable must be used according to the European CE requirements if a Variable Frequency Drive (VFD) is used. For more information, contact your Grindex representative (VFD-supplier).
- For SUBCAB cables, the twisted pair copper foil must be trimmed.

Earthing (Grounding)



Electrical Hazard:

- You must earth (ground) all electrical equipment. This applies to the pump equipment, the driver, and any monitoring equipment. Test the earth (ground) lead to verify that it is connected correctly.
 - If the motor cable is jerked loose by mistake, the earth (ground) conductor should be the last conductor to come loose from its terminal. Make sure that the earth (ground) conductor is longer than the phase conductors. This applies to both ends of the motor cable.
 - Risk of electrical shock or burn. You must connect an additional earth-(ground-) fault protection device to the earthed (grounded) connectors if persons are likely to come into physical contact with the pump or pumped liquids.
-

Earth (ground) conductor length

The earth (ground) conductor must be 200mm (7.9 in) longer than the phase conductors in the junction box of the unit.

Connect the motor cable to the pump



CAUTION:

Leakage into the electrical parts can cause damaged equipment or a blown fuse. Keep the end of the motor cable above the liquid level.

1. Check the data plate to see which connections are required for the power supply.
2. Connect the motor cable conductors, including earth (ground), to the terminal or starter unit.
3. Make sure that the pump is correctly connected to earth (ground).
4. Firmly tighten the cable entry into its bottom-most position.
The seal sleeve and the washers must conform to the outside diameter of the cables.



WARNING:

Do not install the starter equipment in an explosive zone unless it is explosion-proof rated.

Cable charts

Connection locations

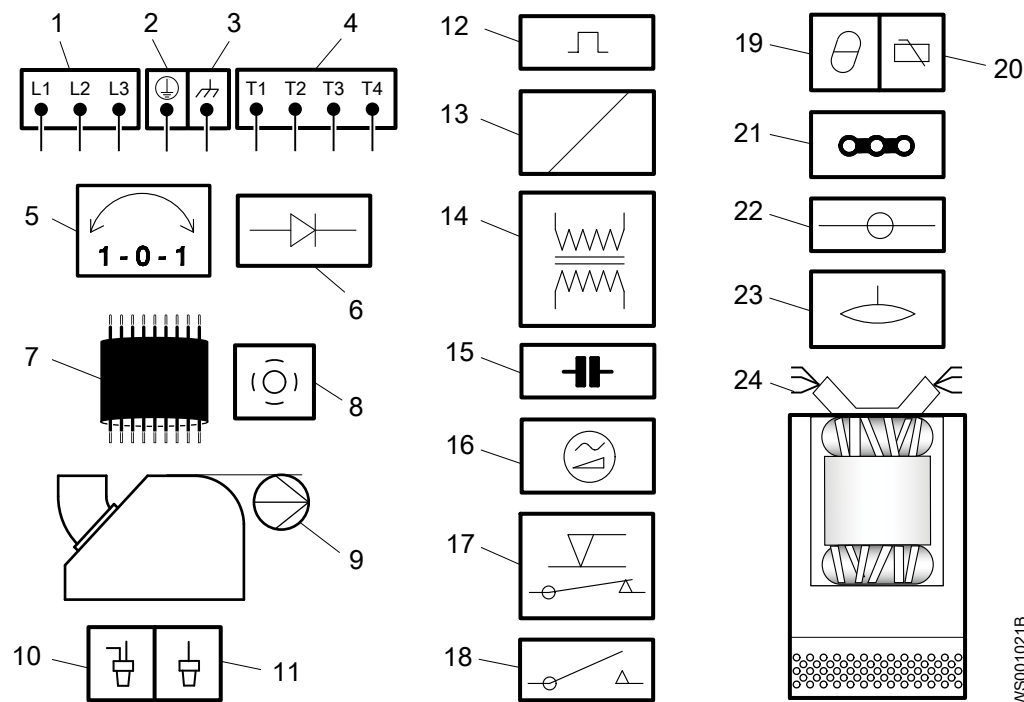

1	Starter equipment and main leads (L1, L2, L3)	13	Coil
2	Earth (ground)	14	Transformer
3	Functional ground	15	Capacitor

4	Control leads (T1, T2, T3, T4)	16	Softstarter
5	Phase shifter	17	Level regulator
6	Diode	18	Contactora, start relay or thermal relay
7	Motor cable	19	Thermal detector in stator
8	Screen	20	Thermal detector in main bearing
9	Pump	21	Jumper
10	Crimp connection	22	Terminal board, terminal plate
11	Crimp isolation	23	Leakage sensor
12	Motor protector	24	Stator leads (U1, U2, U5, U6, V1, V2, V5, V6, W1, W2, W5, W6, Z1, Z5, Z6)

Color code standard

Code	Description
BN	Brown
BK	Black
WH	White
OG	Orange
GN	Green
GNYE	Green-Yellow
RD	Red
GY	Grey
BU	Blue
YE	Yellow

Stator leads and thermal contacts connection to the terminal plate

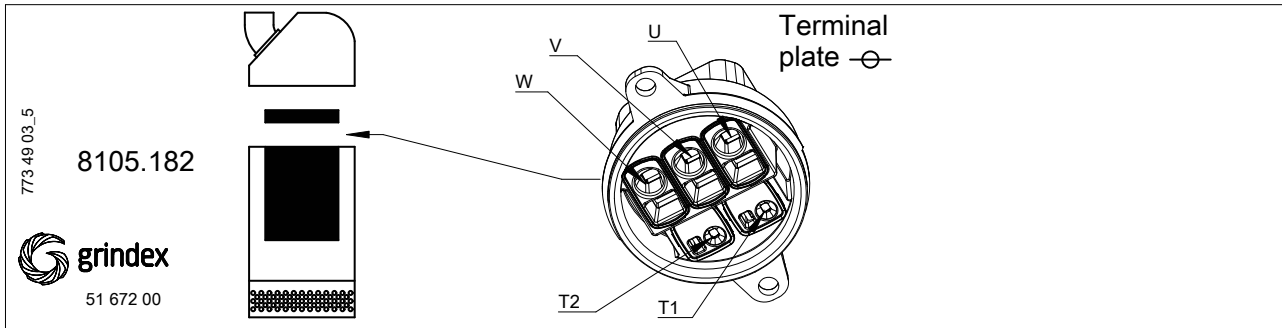

STATOR LEADS AND THERMAL CONTACTS

Terminal plate	3 leads Y	6 leads D	6 leads Y	9 leads Y serial	9 leads Y //	12 leads Y //	12 leads D serial	12 leads D //
W	W	W1 V2	W1	W1	W1 W5	W1 W5	W1 V6	W1 W5 V2 V6
V	V	V1 U2	V1	V1	V1 V5	V1 V5	V1 U6	V1 V5 U2 U6
U	U	U1 W2	U1	U1	U1 U5	U1 U5	U1 W6	U1 U5 W2 W6
T1	T1	T1	T1	T1	T1	T1	T1	T1
T2	T2	T2	T2	T2	T2	T2	T2	T2

W2	W2-W5	W2	W2-W6	W2-W5
V2	V2-V5	V2	V2-V6	V2-V5
U2	U2-U5	U2	U2-U6	U2-U5

STATOR LEADS

U1,U5 RD
U2,U6 GN
V1,V5 BN
V2,V6 BU
W1,W5 YE
W2,W6 BK
T1,T2 WH/YE

CABLE SEAL FOR Y/D STARTER

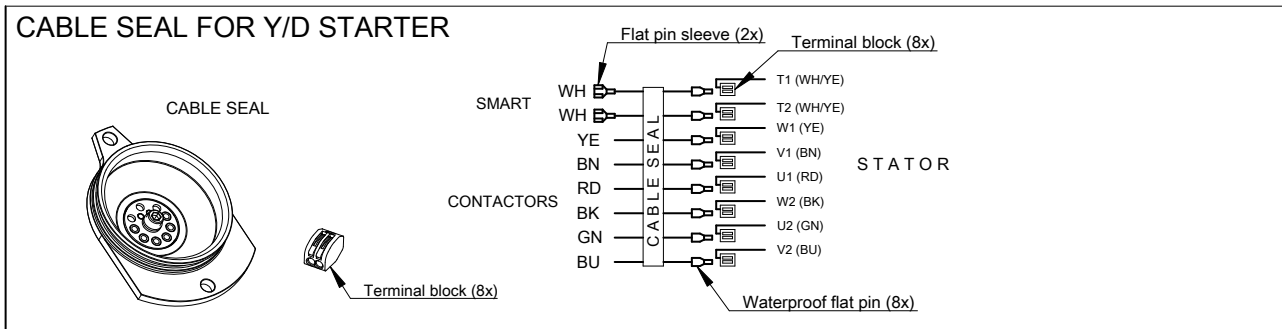

WS004928B

Motor cable and starter unit connection to the terminal plate

773 49 03.5

8105.182



51 672 00

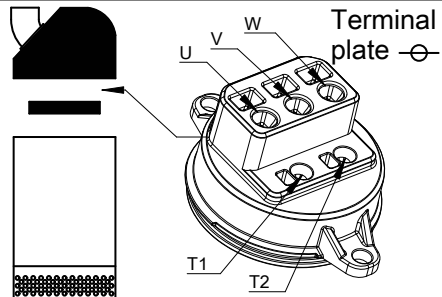

Terminal plate

U V W

T1 T2

SYMBOLS AND DENOMINATIONS

BN=Brown		=Terminal plate
BK=Black		=Screen
WH=White		=Ground
OG=Orange		=Functional ground
GN=Green		=Crimp isolation
GNYE=Green-Yellow		=Crimp connection
RD=Red		=Flat pin sleeve
GY=Grey		=Inside pump
BU=Blue		Pump
YE=Yellow		

*SUBCAB AWG/CSA
**GC= Ground check

PHASE SHIFTER ON MOTOR CABLE

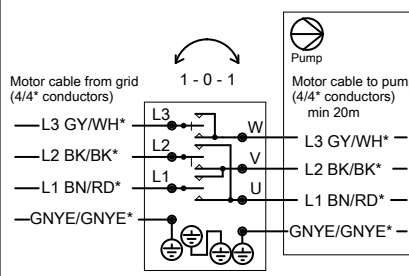

Motor cable from grid (4/4* conductors)

- L3 GY/WH*
- L2 BK/BK*
- L1 BN/RD*
- GNYE/GNYE*

1 - 0 - 1

Motor cable to pump (4/4* conductors) min 20m

- L3 GY/WH*
- L2 BK/BK*
- L1 BN/RD*
- GNYE/GNYE*

SCREENED MOTOR CABLES

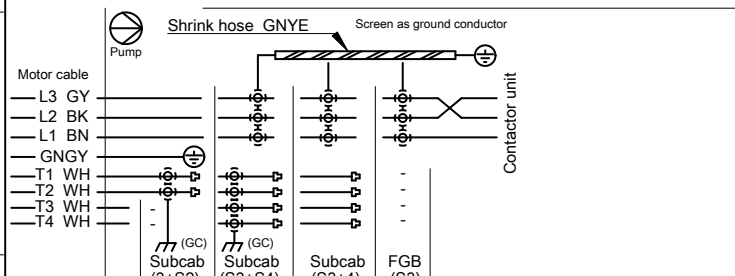

Shrink hose GNYE

Screen as ground conductor

Motor cable

- L3 GY
- L2 BK
- L1 BN
- GNGY
- T1 WH
- T2 WH
- T3 WH
- T4 WH

Subcab (3+S2)

Subcab (S3+S4)

Subcab (S3+4)

FGB (S3)

Contactor unit

INTERNAL CONTACTOR, DOL

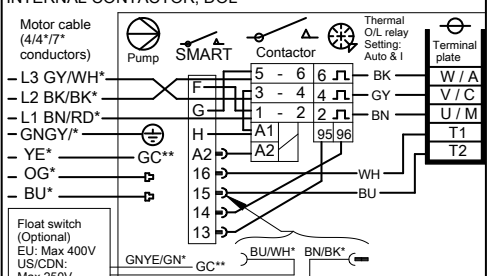

Motor cable (4/4*7* conductors)

- L3 GY/WH*
- L2 BK/BK*
- L1 BN/RD*
- GNGY/*
- YE*
- OG*
- BU*

SMART

Contactor

Thermal O/L relay Setting: Auto & I

Terminal plate

- W / A
- V / C
- U / M
- T1
- T2

Float switch (Optional)

EU: Max 400V
US/CDN: Max 250V

INTERNAL SOFTSTARTER

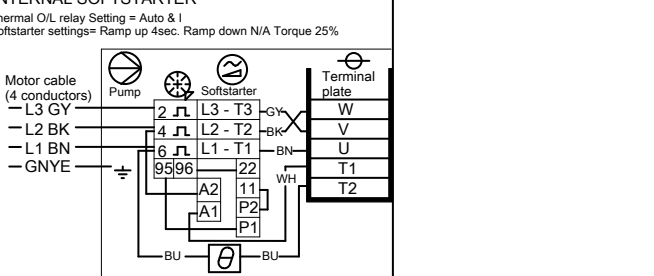

Thermal O/L relay Setting = Auto & I

Softstarter settings= Ramp up 4sec. Ramp down N/A Torque 25%

Motor cable (4 conductors)

- L3 GY
- L2 BK
- L1 BN
- GNYE

Softstarter

Terminal plate

- W
- V
- U
- T1
- T2

Thermal contact

CONTACTOR UNIT, 3-PHASE, FLOAT SWITCH. EU OVER 400V, US/CDN OVER 250V

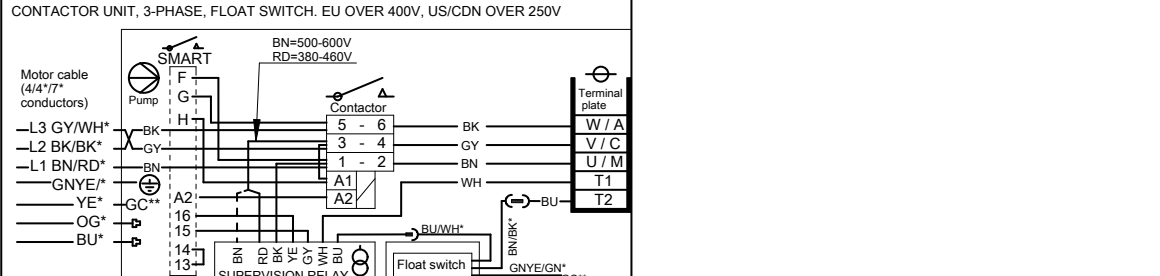

Motor cable (4/4*7* conductors)

- L3 GY/WH*
- L2 BK/BK*
- L1 BN/RD*
- GNYE/*
- YE*
- OG*
- BU*

SMART

Contactor

BN=500-600V
RD=380-460V

Terminal plate

- W / A
- V / C
- U / M
- T1
- T2

BU/WH*

BN/BK*

GNYE/GN*_{GC**}

SUPERVISION RELAY

Float switch

CONTACTOR UNIT Y/D

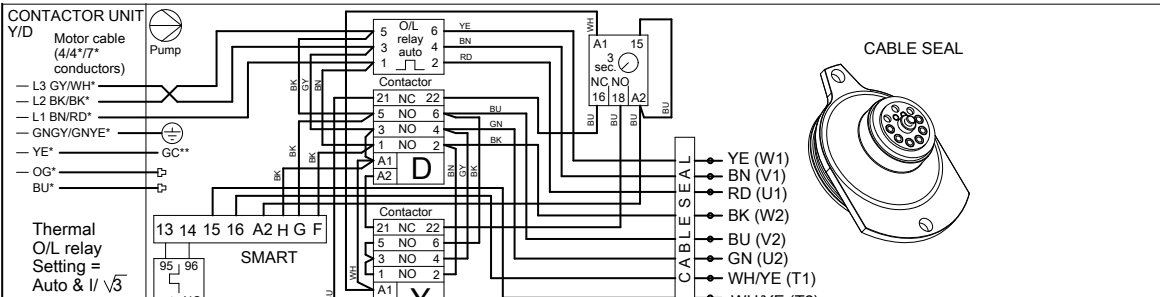

Motor cable (4/4*7* conductors)

- L3 GY/WH*
- L2 BK/BK*
- L1 BN/RD*
- GNGY/GNYE*
- YE*
- OG*
- BU*

SMART

Contactor

OIL relay auto 4

Terminal plate

- W (U1)
- BN (V1)
- RD (U1)
- BK (W2)
- BU (V2)
- GN (U2)
- WH/YE (T1)
- WH/YE (T2)

Thermal O/L relay Setting = Auto & I/√3

CABLE SEAL

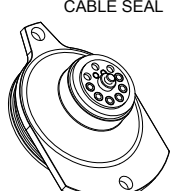

WS004929B

Cable charts, MSHA version

Motor 60 Hz, 3-phase, 440-480V Y or 575-600V Y

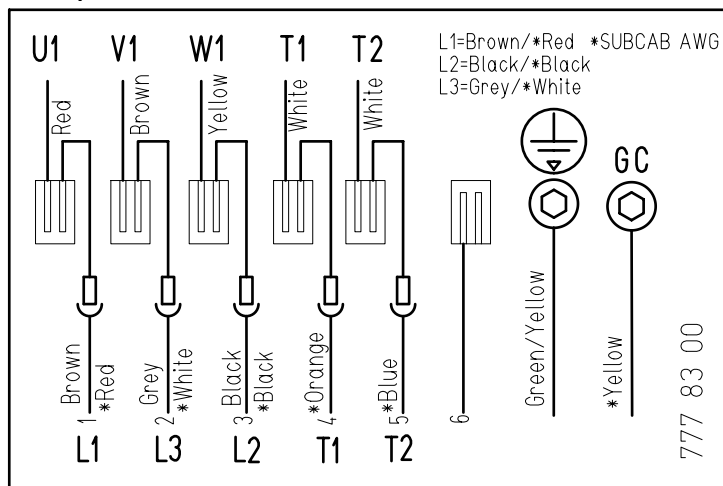

WS004859A

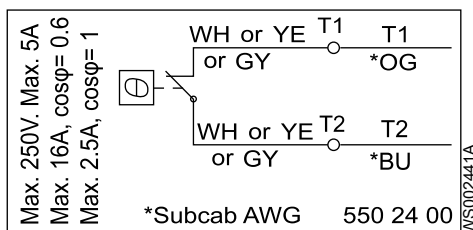

WS002441A

Check the impeller rotation: Pumps without built-in motor protection

Follow this procedure if your product does not have the rotation control SMART™ or softstarter.



WARNING:

The starting jerk can be powerful.

Check the direction of rotation each time the cable has been re-connected and after phase or total supply failure.

1. Start the motor.
2. Stop the motor.
3. Check that the impeller rotates in the correct direction.

The correct direction of impeller rotation is clockwise when you look at the pump from above. When started, the pump will react in the opposite direction to the impeller rotation.

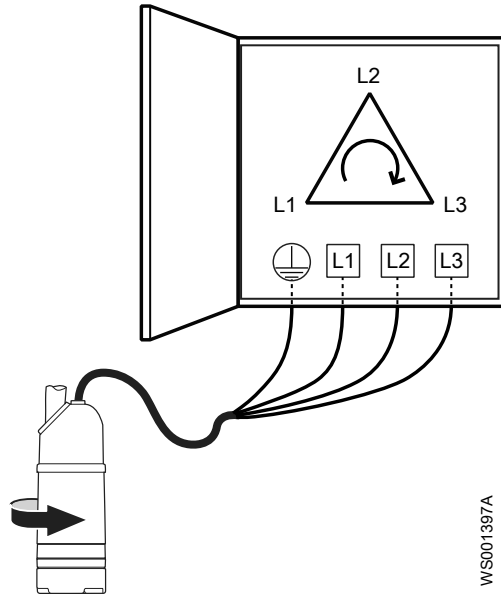

Figure 2: Start reaction

4. If the impeller rotates in the wrong direction, then do the following:
 - If the motor has a 3-phase connection, then transpose two phase conductors and repeat this procedure from step 1.

For 3-phase pumps with external starters or without built-in motor protection, the phases must be shifted on the output terminal of the starter.

Check the phase sequence: Pumps with built-in motor protection

Follow this procedure if your product is equipped with the rotation control SMART™ or softstarter.



WARNING:

The starting jerk can be powerful.

The correct direction of impeller rotation is clockwise when you look at the pump from above. When started, the pump will react in the opposite direction to the impeller rotation.

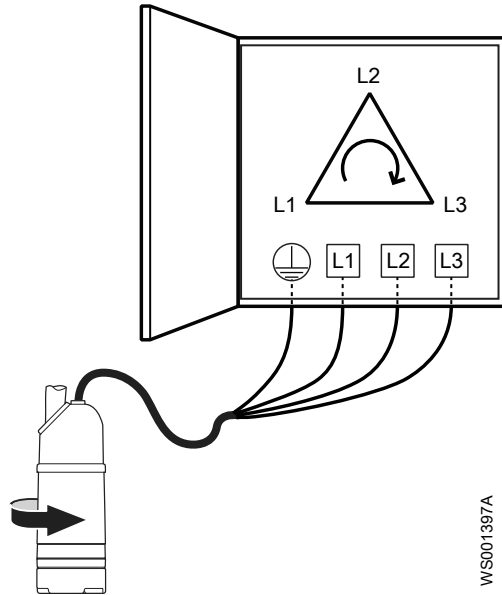
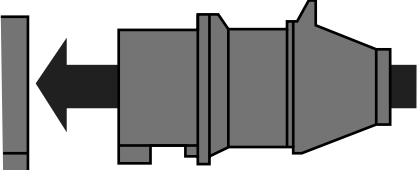
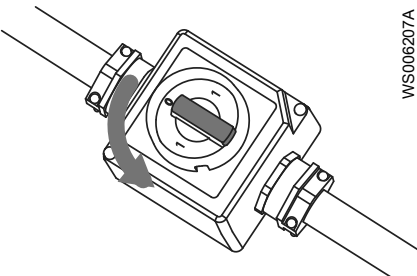

Figure 3: Start reaction

1. Connect the pump to power as follows:

Condition	Action
The pump has a CEE plug with internal phase shifter.	Connect the plug. 
The pump has a phase shifter with an on/off switch.	Turn the knob on the phase shifter in either direction. 
The pump has neither a CEE plug with internal phase shifter, nor a phase shifter with an on/off switch.	1. Connect the pump to power. 2. Switch on the power.

The pump should start. If it does not, then continue to the next step.

2. If the pump does not start and the fuses are correct, then shift two phases:

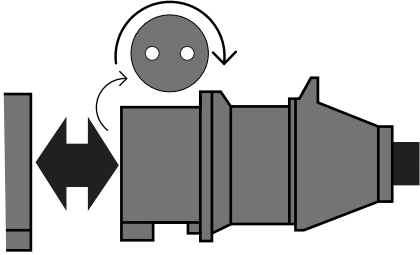
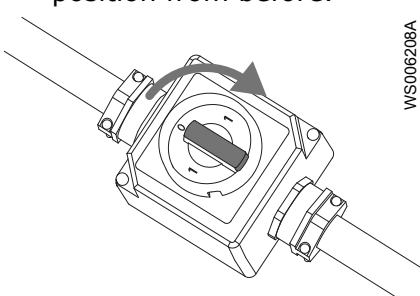
Condition	Action
<p>The pump has a CEE plug with internal phase shifter.</p>	<ol style="list-style-type: none"> 1. Pull out the plug. 2. Shift two phases. 3. Wait until the motor has stopped. 4. Connect the plug.  <p style="text-align: right; font-size: small;">WS006206A</p>
<p>The pump has a phase shifter with an on/off switch.</p>	<ol style="list-style-type: none"> 1. Turn the knob on the phase shifter to neutral position. 2. Wait until the motor has stopped. 3. Turn the knob to the opposite position from before.  <p style="text-align: right; font-size: small;">WS006208A</p>
<p>The pump has neither a CEE plug with internal phase shifter, nor a phase shifter with an on/off switch.</p>	<p>Transpose two phase leads on the output terminal of the starter.</p>

NOTICE:

Do not reverse the phase sequence while the pump is running. Temporarily incorrect rotation can occur, resulting in damage to motor electronics and rotating parts.

The pump should start. If it does not, then contact a certified electrician to check the mains and the junctions.

Operation

Precautions



WARNING:

- Never operate the pump without safety devices installed.
- Never operate the pump with the discharge line blocked, or the discharge valve closed.
- Make sure you have a clear path of retreat.
- Never work alone.



CAUTION:

If the pump is equipped with automatic level control and/or internal contactor, there is a risk of sudden restart.

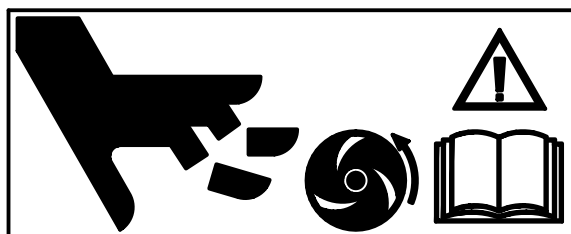

WS006209A

Distance to wet areas



Electrical Hazard:

- Risk of electrical shock. Make sure no one gets closer than 20 m (65 ft.) to the unit when being in contact with the pumped or mixed liquid.
- Risk of electrical shock. This unit has not been investigated for use in swimming pools. If used in connection with swimming pools special safety regulations apply.

Noise level

NOTICE:

The noise level of the product is lower than 70 dB. However, the noise level of 70 dB may be exceeded in some installations and at certain operating points on the performance curve. Make sure that you understand the noise level requirements in the environment where the pump is installed. Failure to do so may result in hearing loss or violation of local laws.

Start the pump



DANGER:

If you need to work on the pump, make sure that it is isolated from the power supply and cannot be energized.



WARNING:

- Make sure that the unit cannot roll or fall over and injure people or damage property.
 - In some installations, the pump and the surrounding liquid may be hot. Bear in mind the risk of burn injuries.
 - Make sure nobody is close to the unit when it is started. The unit will jerk in the opposite direction of the impeller rotation.
-

NOTICE:

Make sure that the rotation of the impeller is correct. For more information, see Check the impeller rotation.

1. Inspect the pump. Check that there is no physical damage to the pump or cables.
2. Check the oil level in the oil housing.
3. Remove the fuses or open the circuit breaker, and check that the impeller can be rotated freely.
4. Check that the monitoring equipment (if any) works.
5. Check that the impeller rotation is correct.
6. Start the pump.

Clean the pump

The pump must be cleaned if it has been running in very dirty water. If clay, cement or other similar dirt is left in the pump it may clog the impeller and seal, preventing the pump from working.

Let the pump run for a while in clean water, or flush it through the discharge connection.

Maintenance

Precautions



DANGER:

Disconnect and lock out electrical power before installing or servicing the unit.



WARNING:

- Always follow safety guidelines when working on the product. See [Introduction and Safety](#) (page 3).
 - Make sure that the unit cannot roll or fall over and injure people or damage property.
 - Rinse the unit thoroughly with clean water before working on the unit.
 - Rinse the components in water after dismantling.
-

Make sure that you follow these requirements:

- Check the explosion risk before you weld or use electrical hand tools.
- Allow all system and pump components to cool before you handle them.
- Make sure that the product and its components have been thoroughly cleaned.
- Do not open any vent or drain valves or remove any plugs while the system is pressurized. Make sure that the pump is isolated from the system and that pressure is relieved before you disassemble the pump, remove plugs, or disconnect piping.

Maintenance guidelines

During the maintenance and before reassembly, always remember to perform these tasks:

- Clean all parts thoroughly, particularly O-ring grooves.
- Change all O-rings, gaskets, and seal washers.
- Lubricate all springs, screws, O-rings with grease.

For an optimal corrosion protection, all O-rings and adjacent surfaces must be coated with Exxon Mobil Unirex N3 or equivalent.

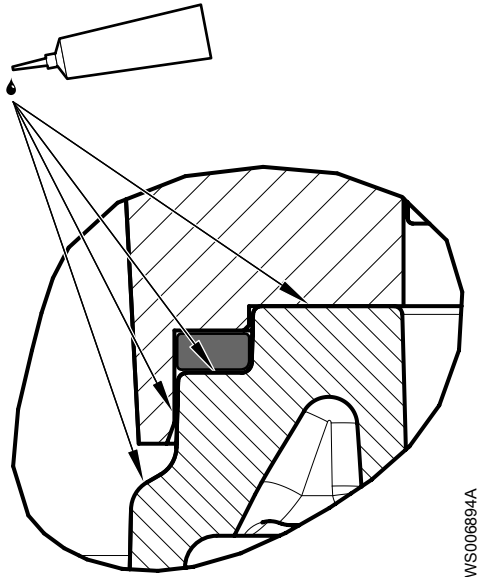

Figure 4: Example of O-ring adjacent surfaces

During the reassembly, always make sure that existing index markings are in line.

The reassembled drive unit must always be insulation-tested and the reassembled pump must always be test-run before normal operation.

Torque values

All screws and nuts must be lubricated to achieve correct tightening torque. Screws that are screwed into stainless steel must have the threads coated with suitable lubricants to prevent seizing.

If there is a question regarding the tightening torques, please contact the local sales and service representative.

Screws and nuts

Table 1: Stainless steel, A2 and A4, torque Nm (ft-lbs)

Property class	M4	M5	M6	M8	M10	M12	M16	M20	M24	M30
50	1.0 (0.74)	2.0 (1.5)	3.0 (2.2)	8.0 (5.9)	15 (11)	27 (20)	65 (48)	127 (93.7)	220 (162)	434 (320)
70, 80	2.7 (2)	5.4 (4)	9.0 (6.6)	22 (16)	44 (32)	76 (56)	187 (138)	364 (268)	629 (464)	1240 (915)
100	4.1 (3)	8.1 (6)	14 (10)	34 (25)	66 (49)	115 (84.8)	248 (183)	481 (355)	—	—

Table 2: Steel, torque Nm (ft-lbs)

Property class	M4	M5	M6	M8	M10	M12	M16	M20	M24	M30
8.8	2.9 (2.1)	5.7 (4.2)	9.8 (7.2)	24 (18)	47 (35)	81(60)	194 (143)	385 (285)	665 (490)	1310 (966.2)
10.9	4.0 (2.9)	8.1 (6)	14 (10)	33 (24)	65 (48)	114 (84)	277 (204)	541 (399)	935 (689)	1840 (1357)

Property class	M4	M5	M6	M8	M10	M12	M16	M20	M24	M30
12.9	4.9 (3.6)	9.7 (7.2)	17 (13)	40 (30)	79 (58)	136 (100)	333 (245)	649 (480)	1120 (825.1)	2210 (1630)

Hexagon screws with countersunk heads

For hexagon socket head screws with countersunk head, maximum torque for all property classes must be 80% of the values for property class 8.8 above.

Service

Regular inspection and service of the pump ensures more reliable operation.

Type of service	Purpose	Inspection interval
Inspection	To prevent operational interruptions and machine breakdown. Measures to secure performance and pump efficiency are defined and decided for each individual application. It can include such things as impeller trimming, wear part control and replacement, control of zinc-anodes and control of the stator.	Twice a year
Major overhaul	To secure a long operating lifetime for the product. It includes replacement of key components and the measures taken during an inspection.	Every year, under normal operating conditions

NOTICE:

Shorter intervals may be required when the operating conditions are extreme, for example with very abrasive or corrosive applications or when the liquid temperatures exceed 40°C (104°F).

Inspection

Regular inspection and service of the pump ensures more reliable operation.

Service item	Action
Visible parts on the pump and installation	<ol style="list-style-type: none"> 1. Check that all screws, bolts, and nuts are properly tightened. 2. Check the condition of the pump casing, strainer, cover, lifting handles, eye bolts, ropes, chains, and wires. 3. Check for worn or damaged parts. 4. Adjust and/or replace if necessary.
Pipes, valves, and other peripheral equipment	<ol style="list-style-type: none"> 1. Check for worn or damaged parts. 2. Adjust and/or replace if necessary.
Impeller	<ol style="list-style-type: none"> 1. Check for worn or damaged parts. 2. Adjust and/or replace if necessary. <p>Wear on the impeller or surrounding parts necessitates fine adjustments of the impeller or replacement of worn parts.</p>

Service item	Action
Oil	<p>Check the oil:</p> <ol style="list-style-type: none"> 1. Take an oil sample. 2. If the oil contains particles, then replace the mechanical seal. Contact an authorized service shop. <p>Make sure that the volume is filled to the correct level. See Fill with oil (page 32).</p> <p>A smaller amount of water is not harmful for the mechanical seal.</p>
Cable entry	<ol style="list-style-type: none"> 1. Check that the following requirements are met: <ul style="list-style-type: none"> • The cable entry must be firmly tightened into its bottom-most position. • MSHA pump version: The cable entry must be tightened so that the clearance between the gland screw and the MSHA cover is >3.175 mm (1/8 in). Use a feeler gauge to check the clearance. • MSHA pump version: The gland screw is secured from rotating with a screw and washer. • The seal sleeve and the washers must conform to the outside diameter of the cables. 2. Cut off a piece of the cable so that the seal sleeve closes around a new position on the cable. 3. Replace the seal sleeve, if necessary.
Inspection volume ¹	<ol style="list-style-type: none"> 1. Check that the inspection screw is properly tightened. 2. Remove the inspection screw. 3. Drain all liquid, if any. 4. If there is oil in the inspection volume, then empty the oil and check again after one week. If there is oil in the inspection volume again, then replace the mechanical seal. Contact an authorized service shop. 5. If there is water in the inspection volume, then check that the inspection screw O-ring is not damaged.
Cable	<ol style="list-style-type: none"> 1. If the outer jacket is damaged, replace the cable. 2. Check that the cables do not have any sharp bends and are not pinched.
Cooling system	If the flow through the system has been partly restricted, then rinse and clean.
Level sensors or other sensor equipment	<ol style="list-style-type: none"> 1. Check the functionality. 2. Repair or replace any damaged equipment. 3. Clean and adjust the equipment.
Starter equipment	<ol style="list-style-type: none"> 1. Check the condition and functionality. 2. Contact an electrician, if necessary.
Insulation resistance in the stator	<ol style="list-style-type: none"> 1. Check the insulation between: <ul style="list-style-type: none"> • Phase–phase on the stator • Phase–earth (ground) <p>The insulation should be > 1 megohm. Use a 1000-VDC megger to test the insulation.</p> 2. If the resulting value is < 1 megohm, then contact an authorized service shop.

¹ Regardless of individual applications, the inspection volume should not be inspected less frequently than the intervals for normal applications and operating conditions at media (liquid) temperatures <40°C (104°F).

Major overhaul

For a major overhaul, take this action in addition to the tasks listed under Inspection.

Service item	Action
Support and main bearing	Replace the bearings with new bearings.
Mechanical seal	Replace with new seal units.

Change the oil

A paraffin oil with viscosity close to ISO VG32 is recommended. The pump is delivered from the factory with this type of oil. In applications where poisonous properties are of less concern, a mineral oil with viscosity up to ISO VG32 can be used.



1. Inspection screw
2. Oil screw

Figure 5: Symbols

Empty the oil

1. Lay the pump on its side.
Lock the pump with supports to prevent it from rolling over.
2. Remove the oil screw.

There are two oil screws. Either screw can be used for drainage, but it is easier to drain the oil if both oil screws are removed.



WARNING:

The oil housing may be pressurized. Hold a rag over the oil plug to prevent oil from spraying out.

3. Turn the pump so that the oil hole faces downwards and let the oil run out.

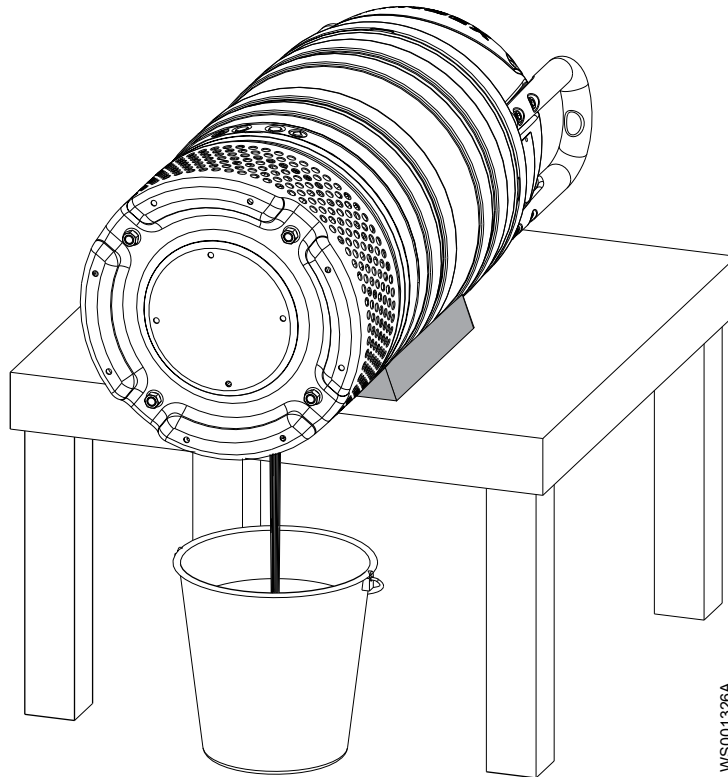

WS001326A

Fill with oil

1. Replace the oil screw O-ring.
2. Put one of the oil screws back and tighten it.
3. Turn the pump so that the oil hole faces upwards and fill with new oil.
Fill until the oil level reaches the inlet hole.
Quantity: 1.45 L (1.53 qt)
4. Put the oil screw back and tighten it.

Replace the impeller

Remove the impeller N, H



WARNING:

A worn impeller and/or pump housing can have very sharp edges. Wear protective gloves.

1. Remove the strainer.

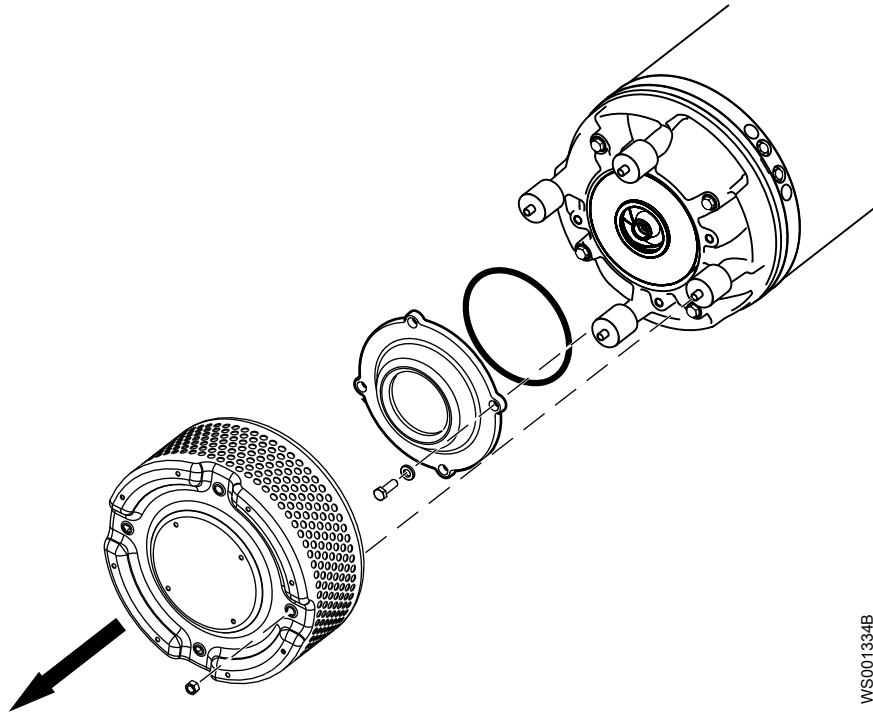

WS001334B

2. Remove the suction cover.
3. Remove the O-ring.
4. Loosen the impeller:
 - a) Lock the impeller to prevent rotation.
Use pliers, a screwdriver, or similar.
 - b) Remove the impeller screw and washer.

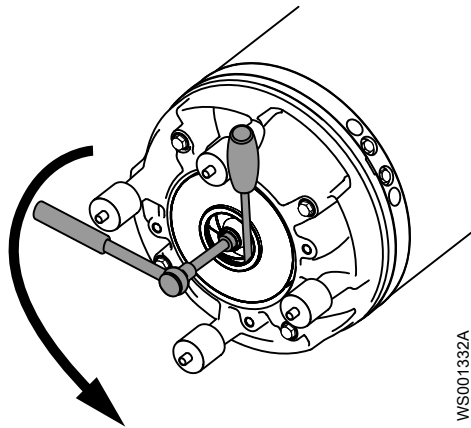

WS001332A

5. Remove the impeller:
 - a) Lock the impeller to prevent rotation.
Use pliers, a screwdriver, or similar.
 - b) Turn the adjustment screw counterclockwise until the impeller breaks free from the shaft.
Use a 10 mm hexagon bit adapter (Allen socket) with a 100 mm (4 in.) extension.

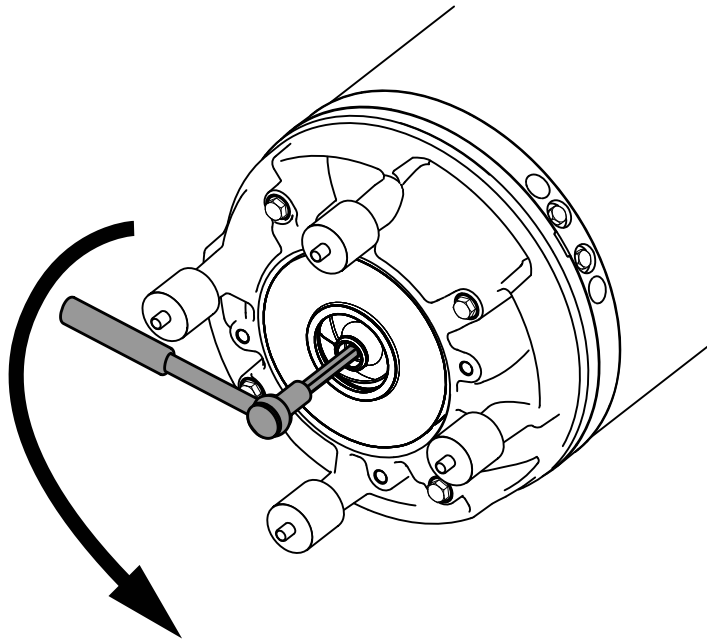

c) Pull off the impeller.

Remove the impeller SH



WARNING:

A worn impeller and/or pump housing can have very sharp edges. Wear protective gloves.

1. Remove the strainer.

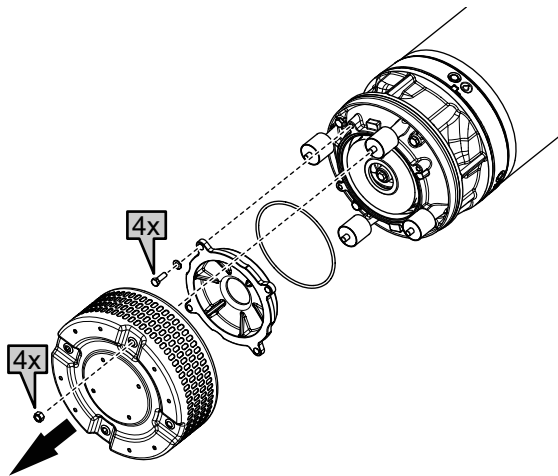

2. Remove the suction cover.
3. Remove the O-ring.
4. Loosen the impeller:
 - a) Lock the impeller to prevent rotation.
Use pliers, a screwdriver, or similar.
 - b) Remove the impeller screw and washer.

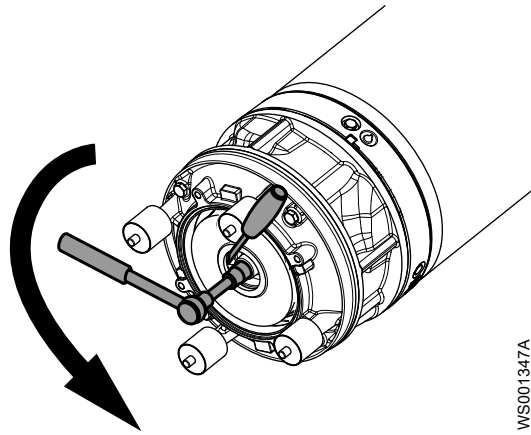

5. Remove the impeller:
 - a) Lock the impeller to prevent rotation.
Use pliers, a screwdriver, or similar.
 - b) Turn the adjustment screw counterclockwise until the impeller breaks free from the shaft.
Use a 10 mm hexagon bit adapter (Allen socket) with a 100 mm (4 in.) extension.

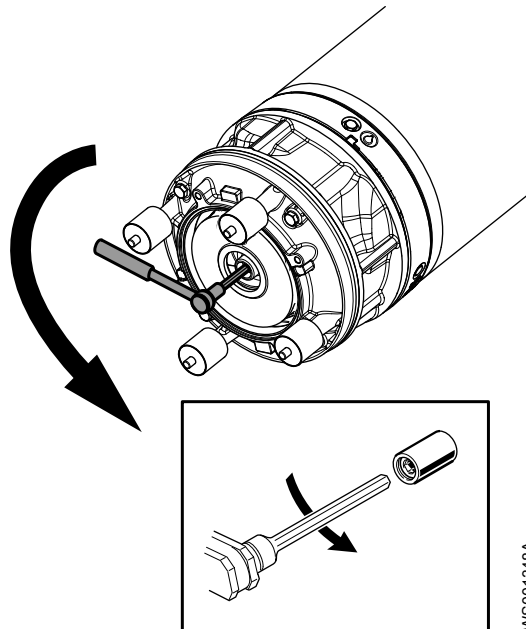

- c) Pull off the impeller.
6. Remove the lower diffuser.

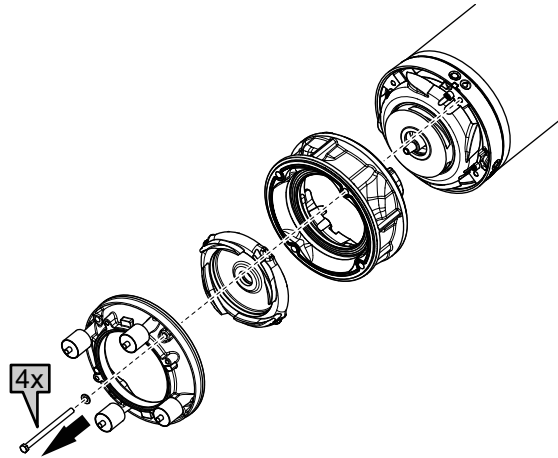

7. Remove the inner diffuser.
8. Remove the upper diffuser.
9. Remove the impeller:
 - a) Lock the impeller to prevent rotation.
Use pliers, a screwdriver, or similar.
 - b) Turn the adjustment screw counterclockwise until the impeller breaks free from the shaft.
Use a 10 mm hexagon bit adapter (Allen socket) with a 100 mm (4 in.) extension.

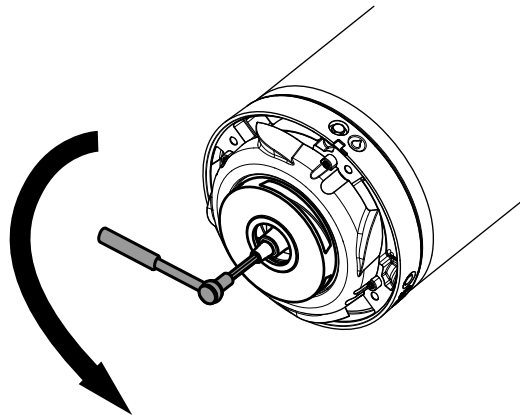

WS001351A

- c) Pull off the impeller.

Install the impeller N, H

1. Prepare the shaft:
 - a) Polish off any flaws with a fine emery cloth.
The end of the shaft must be clean and free from burrs.
 - b) Coat the inner conic, the outer cylindrical surfaces, and the thread of the conical sleeve with a thin layer of grease.
The proper lubrication is grease for bearings, for example Exxon Mobil Unirex N3, Mobil Mobilith SHC 220 or equivalent.

NOTICE:

Surplus grease can cause the impeller to become loose. Remove surplus grease from conical and/or cylindrical surfaces of shafts and/or sleeves.

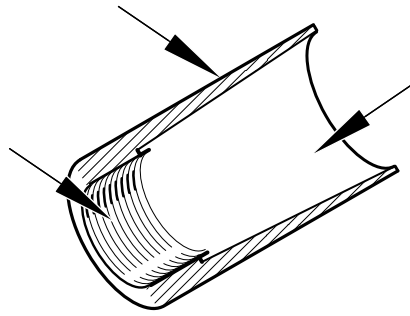

WS006895A

2. Align the edge of the adjustment screw with the edge of the conical sleeve so that they are flush.

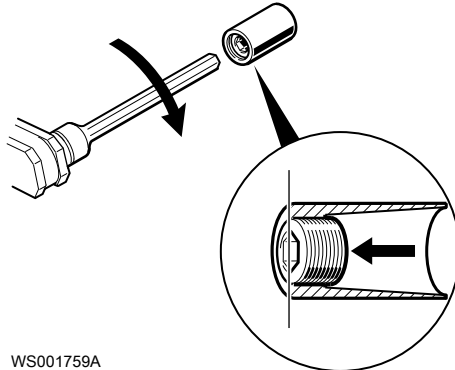

WS001759A

3. Grease the threads of the impeller screw and the washer.
The proper lubrication of the screw and washer is lubricating grease for assembly of bolts etc., for example, Kluber ALTEMP Q NB 50 or equivalent.
4. Check that the impeller screw is clean and easy to screw into the shaft end.
This is to prevent the shaft from rotating with the impeller screw.
5. Assemble the conical sleeve in the impeller.
Make sure that the conical sleeve bottoms in the impeller.

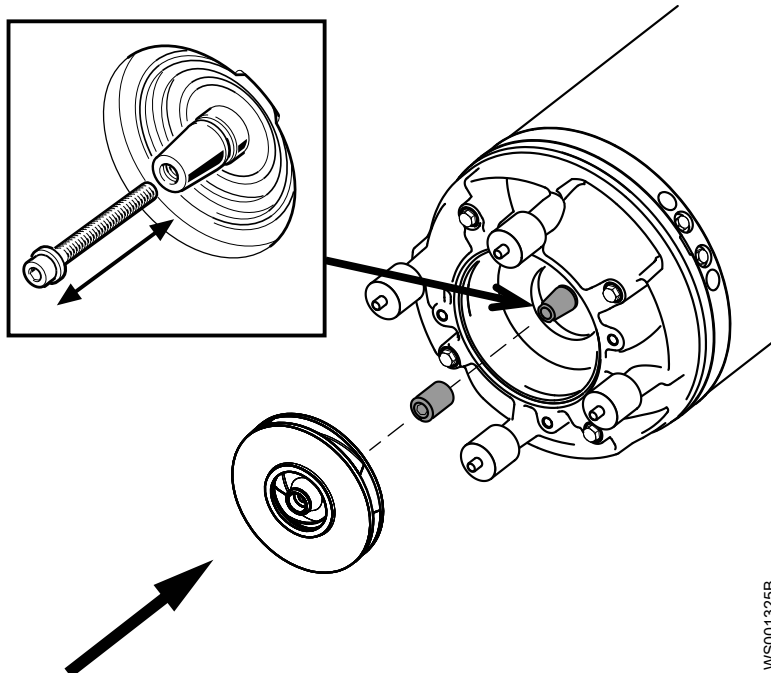

WS001325B

6. Assemble the impeller with the conical sleeve onto the shaft.
Make sure that the conical sleeve bottoms in the impeller.

7. Mount the suction cover with its O-ring and tighten.
Tightening torque: 44 Nm (32.5 ft-lbs)

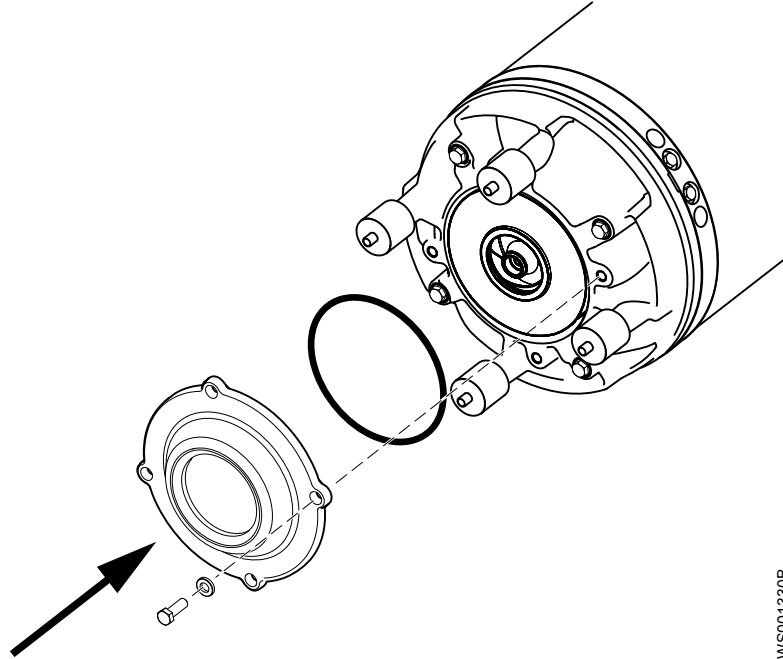

8. Turn the adjustment screw clockwise until the impeller makes contact with the suction cover. Tighten a further 1/8 turn, 45°. This will ensure the correct clearance between the impeller and the suction cover in the next step.
Use a 10 mm hexagon bit adapter (Allen socket).

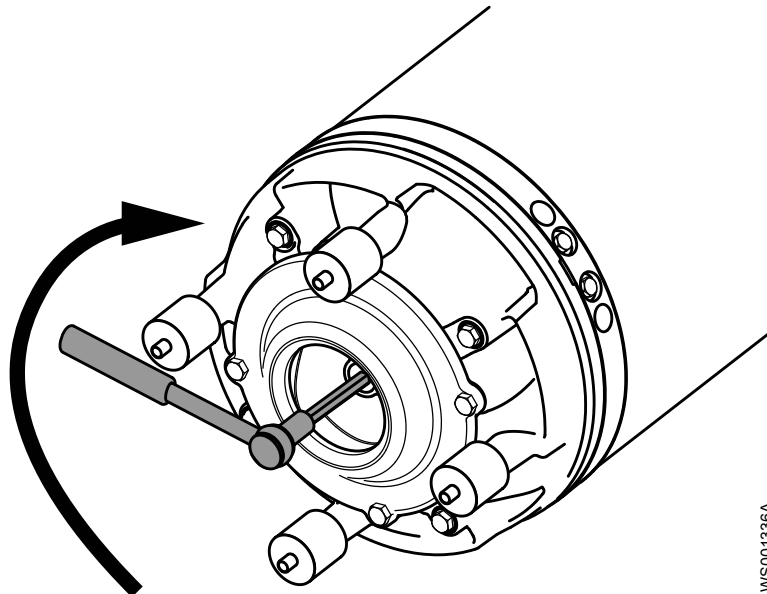

9. Fasten the impeller:
 - a) Place the washer on the impeller screw.
 - b) Lock the impeller to prevent rotation.
Use pliers, a screwdriver, or similar.
 - c) Tighten the impeller screw.
Tightening torque: 44 Nm (32.5 ft-lbs)
 - d) Tighten a further 1/8 turn, 45°.

The screw will be loaded to its yield point and the load capacity of the joint will be higher.

- e) Check that the impeller can rotate easily.

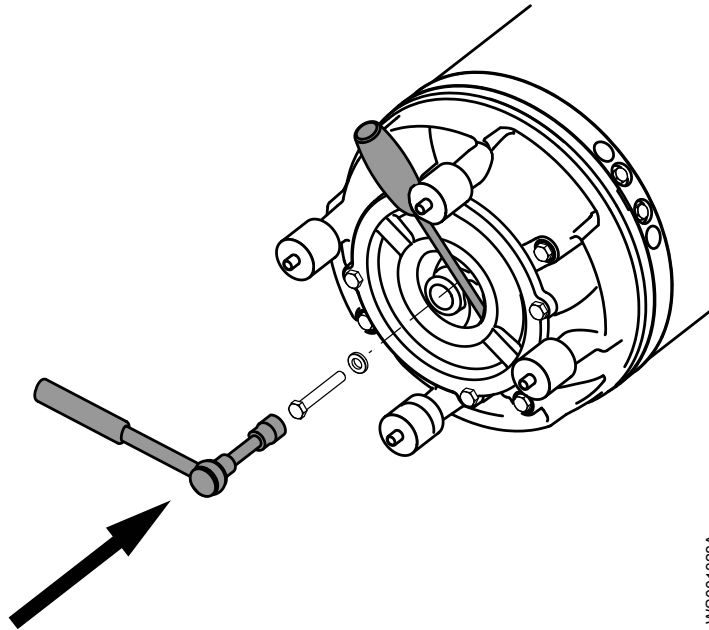

10. Mount the strainer and the nuts.

Tightening torque: 44 Nm (32.5 ft-lbs)

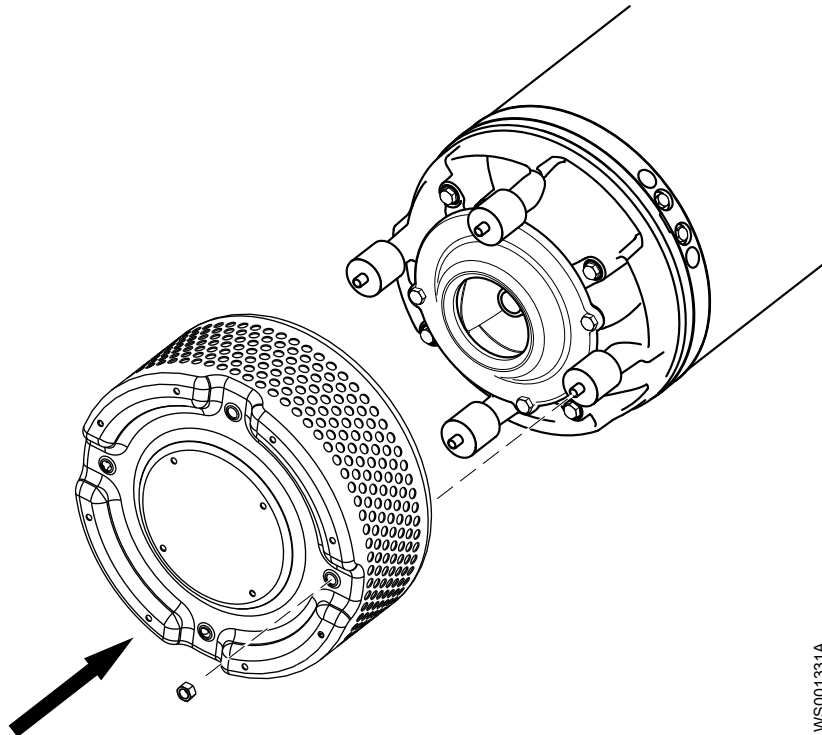

Install the impeller SH

1. Prepare the shaft:
 - a) Polish off any flaws with a fine emery cloth.
The end of the shaft must be clean and free from burrs.
 - b) Coat the inner conic, the outer cylindrical surfaces, and the thread of the conical sleeve with a thin layer of grease.

The proper lubrication is grease for bearings, for example Exxon Mobil Unirex N3, Mobil Mobilith SHC 220 or equivalent.

NOTICE:

Surplus grease can cause the impeller to become loose. Remove surplus grease from conical and/or cylindrical surfaces of shafts and/or sleeves.

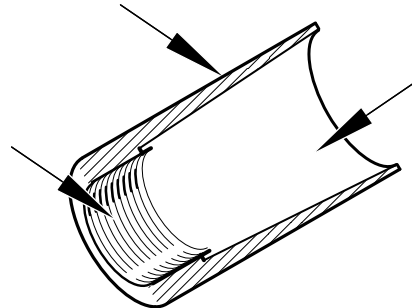

WS006895A

- Align the edge of the upper adjustment screw with the edge of the upper conical sleeve so that they are flush.

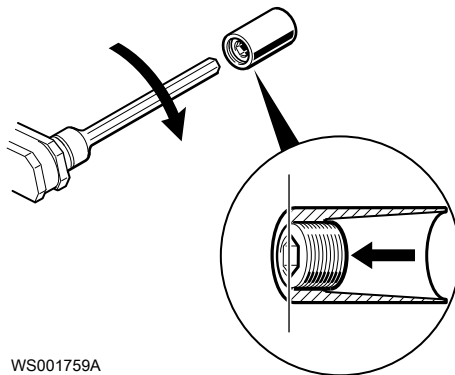

WS001759A

- Grease the threads of the screw and the washer.
The proper lubrication of the screw and washer is lubricating grease for assembly of bolts etc., for example, Kluber ALTEMP Q NB 50 or equivalent.
- Check that the impeller screw is clean and easy to screw into the shaft end (a).

This is to prevent the shaft from rotating with the impeller screw.

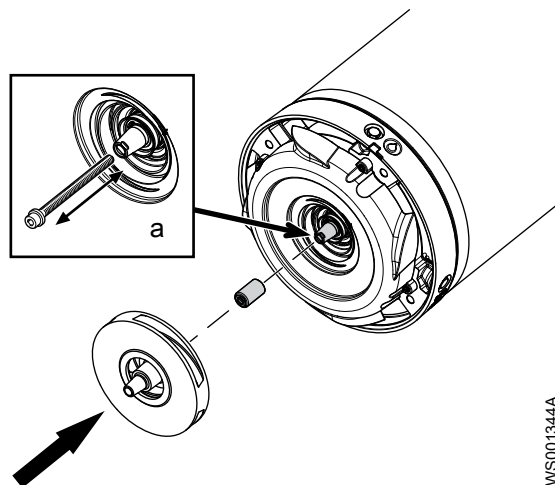

WS001344A

- Assemble the upper conical sleeve and the upper impeller onto the shaft.
- Mount the diffuser parts and tighten.

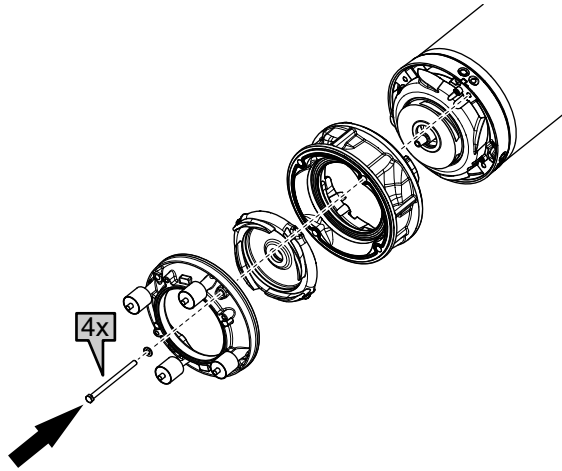

7. Mount the suction cover with its O-ring and tighten.
Tightening torque: 44 Nm (32.5 ft-lbs)

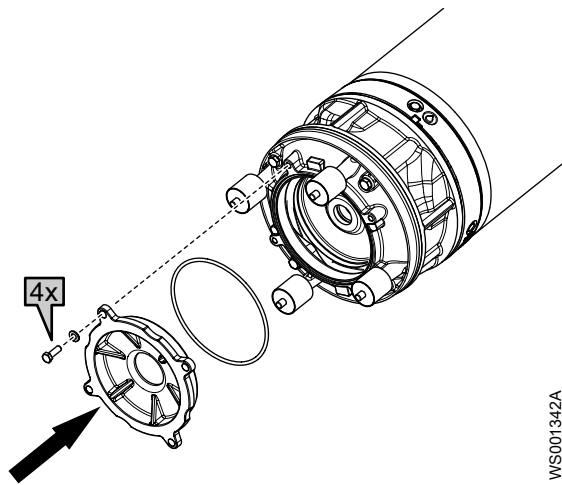

8. Turn the adjustment screw clockwise until the impeller makes contact with the suction cover.
This will ensure the correct clearance between the impeller and the suction cover in the next step.
Use a 10 mm hexagon bit adapter (Allen socket) with a 100 mm (4 in.) extension.

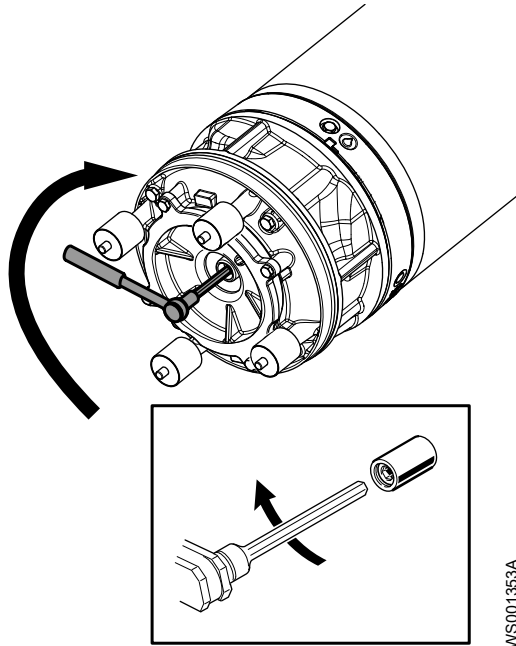

9. Remove the suction cover.

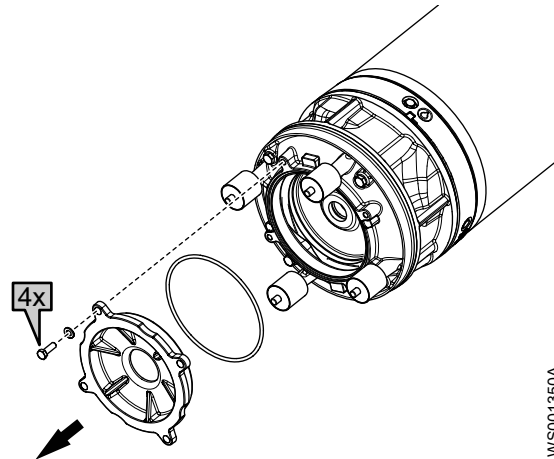

10. Remove the O-ring.

11. Align the edge of the lower adjustment screw with the edge of the lower conical sleeve so that they are flush.

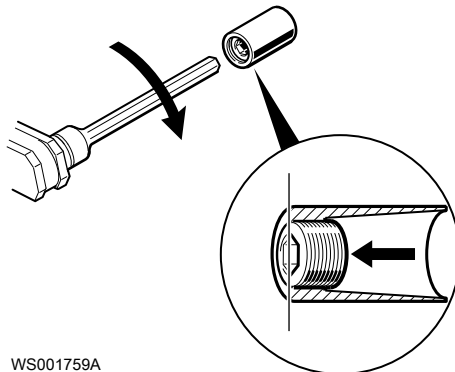

12. Assemble the lower conical sleeve and the lower impeller onto the shaft end of the upper impeller.

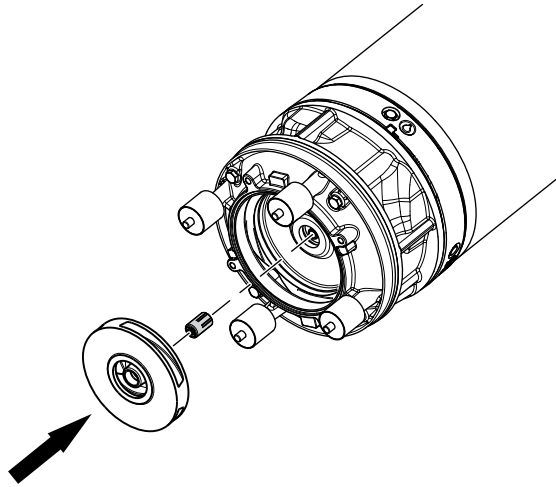

13. Mount the suction cover with its O-ring and tighten.
Tightening torque: 44 Nm (32.5 ft-lbs)

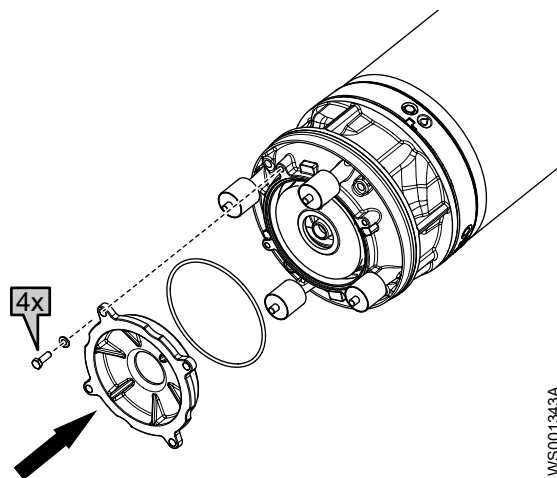

14. Turn the lower adjustment screw clockwise until the lower impeller makes contact with the suction cover. Tighten a further 1/6 turn, 60°.
This will ensure the correct clearance between the lower impeller and the suction cover in the next step.
Use a 10 mm hexagon bit adapter (Allen socket) with a 100 mm (4 in.) extension.

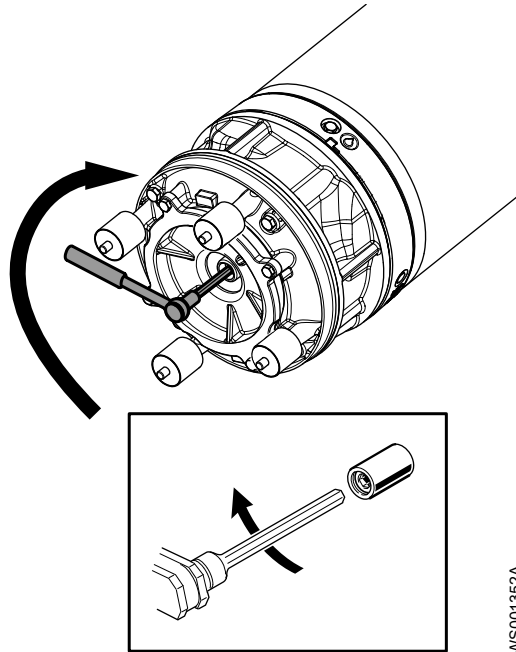

WS001352A

15. Fasten the impeller:

- a) Place the washer on the impeller screw.
- b) Lock the impeller to prevent rotation.
Use pliers, a screwdriver, or similar.
- c) Tighten the impeller screw.
Tightening torque: 44 Nm (32.5 ft-lbs)
- d) Tighten a further 1/8 turn, 45°.
The screw will be loaded to its yield point and the load capacity of the joint will be higher.
- e) Check that both the upper and lower impeller can rotate easily.

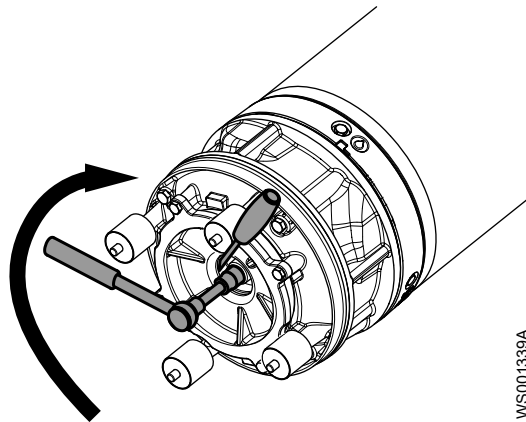

WS001339A

16. Check that the impeller can rotate easily.

If not, the adjustment screw and the conical sleeve have not been aligned, and the shaft may have been displaced relative to the main bearing.

17. Mount the strainer and the nuts.

Tightening torque: 44 Nm (32.5 ft-lbs)

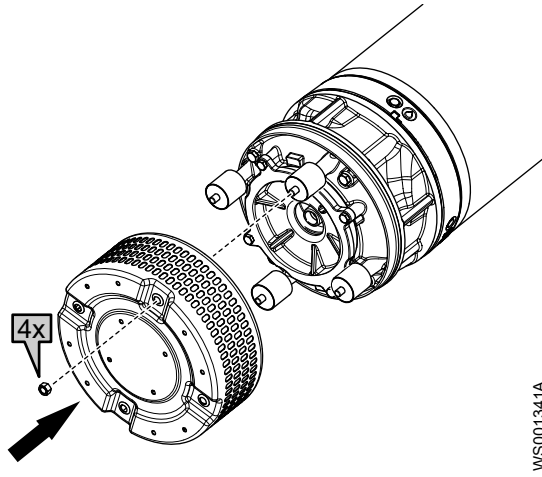

Troubleshooting

Introduction



DANGER:

Personal injury hazard. Troubleshooting a live control panel exposes personnel to hazardous voltages. Electrical troubleshooting must be done by a qualified electrician. Failure to follow these instructions will result in serious personal injury, death, and/or property damage.

Follow these guidelines when troubleshooting the pump:

- Disconnect and lock out the power supply except when conducting checks that require voltage.
- Make sure that no one is near the pump when the power supply is reconnected.
- When troubleshooting electrical equipment, use the following:
 - Universal instrument multimeter
 - Test lamp (continuity tester)
 - Wiring diagram

The pump does not start, for pumps with SMART™ or softstarter

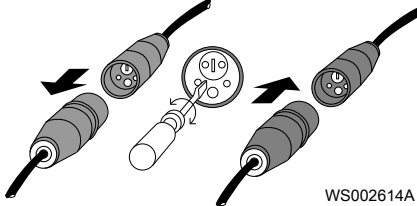
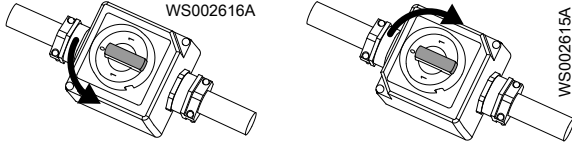
Cause	Remedy
<p>The phase sequence may be incorrect.</p>	<ol style="list-style-type: none"> 1. Pull out the plug. 2. Do one of the following: <ul style="list-style-type: none"> • Shift two phases by turning two contact pins with a screwdriver. <hr/> <p>NOTICE: Do not take the plug apart.</p> <hr/>  <p style="text-align: right;">WS002614A</p> <p>Figure 6: CEE plug</p> <ul style="list-style-type: none"> • Turn the knob to the opposite position 1, with 8 seconds delay. <hr/> <p>NOTICE: Do not reverse the phase sequence while the motor is running. Doing so may cause incorrect rotation resulting in damages to the motor electronics and the rotating parts. Respect the 8 seconds delay.</p> <hr/>  <p style="text-align: center;">WS002616A WS002615A</p> <p>Figure 7: Phase shifter On/Off switch</p> <ul style="list-style-type: none"> • If no glove or phase shifter is used, then shift two phase conductors in the cabinet.

If the problem persists, contact the local Grindex service shop. Always state the product number and the serial number of your pump when you contact Grindex, see [Product Description](#) (page 10).

The pump does not start



WARNING:

Always disconnect and lock out power before servicing to prevent unexpected startup. Failure to do so could result in death or serious injury.

NOTICE:

Do NOT override the motor protection repeatedly if it has tripped. Doing so may result in equipment damage.

Cause	Remedy
An alarm signal has been triggered on the control panel.	Check that: <ul style="list-style-type: none"> • The impeller rotates freely. • The sensor indicators do not indicate an alarm. • The overload protection is not tripped. If the problem still persists: Contact the local Grindex service shop.
The pump does not start automatically, but can be started manually.	Check that: <ul style="list-style-type: none"> • The start level regulator is functioning. Clean or replace if necessary. • All connections are intact. • The relay and contactor coils are intact. • The control switch (Man/Auto) makes contact in both positions. Check the control circuit and functions.
The installation is not receiving voltage.	Check that: <ul style="list-style-type: none"> • The main power switch is on. • There is control voltage to the start equipment. • The fuses are intact. • There is voltage in all phases of the supply line. • All fuses have power and that they are securely fastened to the fuse holders. • The overload protection is not tripped. • The motor cable is not damaged.
The impeller is stuck.	Clean: <ul style="list-style-type: none"> • The impeller • The sump in order to prevent the impeller from clogging again.

If the problem persists, contact the local Grindex service shop. Always state the product number and the serial number of your pump when you contact Grindex, see [Product Description](#) (page 10).

The pump does not stop when a level sensor is used



WARNING:

Always disconnect and lock out power before servicing to prevent unexpected startup. Failure to do so could result in death or serious injury.

Cause	Remedy
The pump is unable to empty the sump to the stop level.	Check that: <ul style="list-style-type: none"> • There are no leaks from the piping and/or discharge connection. • The impeller is not clogged. • The non-return valve(s) are functioning properly. • The pump has adequate capacity. For information: Contact the local Grindex service shop.

Cause	Remedy
There is a malfunction in the level-sensing equipment.	<ul style="list-style-type: none"> • Clean the level regulators. • Check the functioning of the level regulators. • Check the contactor and the control circuit. • Replace all defective items.
The stop level is set too low.	Raise the stop level.

If the problem persists, contact the local Grindex service shop. Always state the product number and the serial number of your pump when you contact Grindex, see [Product Description](#) (page 10).

The pump starts-stops-starts in rapid sequence

Cause	Remedy
The pump starts due to back-flow which fills the sump to the start level again.	Check that: <ul style="list-style-type: none"> • The distance between the start and stop levels is sufficient. • The non-return valve(s) work(s) properly. • The length of the discharge pipe between the pump and the first non-return valve is sufficiently short.
The self-holding function of the contactor malfunctions.	Check: <ul style="list-style-type: none"> • The contactor connections. • The voltage in the control circuit in relation to the rated voltages on the coil. • The functioning of the stop-level regulator. • Whether the voltage drop in the line at the starting surge causes the contactor's self-holding malfunction.

If the problem persists, contact the local Grindex service shop. Always state the product number and the serial number of your pump when you contact Grindex, see [Product Description](#) (page 10).

The pump runs but the motor protection trips



WARNING:

Always disconnect and lock out power before servicing to prevent unexpected startup. Failure to do so could result in death or serious injury.

NOTICE:

Do NOT override the motor protection repeatedly if it has tripped. Doing so may result in equipment damage.

Cause	Remedy
The motor protection is set too low.	Set the motor protection according to the data plate and if applicable the cable chart.
The impeller is difficult to rotate by hand.	<ul style="list-style-type: none"> • Clean the impeller. • Clean out the sump. • Check that the impeller is properly trimmed.

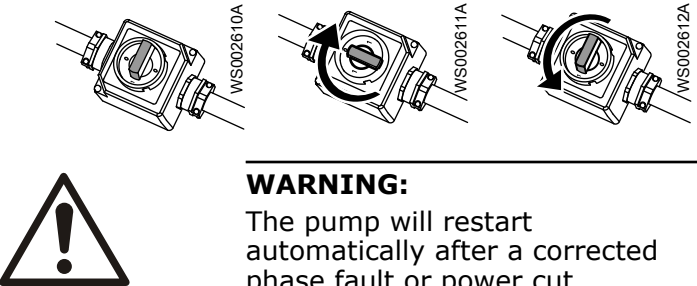
Cause	Remedy
The drive unit is not receiving full voltage on all three phases.	<ul style="list-style-type: none"> • Check the fuses. Replace fuses that have tripped. • If the fuses are intact, notify a certified electrician.
The phase currents vary, or they are too high.	Contact the local Grindex service shop.
The insulation between the phases and ground in the stator is defective.	<ol style="list-style-type: none"> 1. Use an insulation tester. With a 1000 V DC megger, check that the insulation between the phases and between any phase and ground is > 5 megohms. 2. If the insulation is less: Contact the local Grindex service shop.
The density of the pumped fluid is too high.	<p>Make sure that the maximum density is 1100 kg/m³ (9.2 lb/US gal)</p> <ul style="list-style-type: none"> • Change to a more suitable pump. • Contact the local Grindex service shop.
The ambient temperature exceeds the maximum ambient temperature.	The pump must not be used for such an application.
There is a malfunction in the overload protection.	Replace the overload protection.
The SMART™ motor protection may need to be reset.	<p>Try one of the following:</p> <ul style="list-style-type: none"> • Reset the SMART™ motor protection by pulling and reinserting the power plug. • Or, disconnect and reconnect the power. <div style="display: flex; align-items: center; justify-content: center;">  <div style="margin-left: 20px;"> <p>WARNING: The pump will restart automatically after a corrected phase fault or power cut.</p> </div> </div>

If the problem persists, contact the local Grindex service shop. Always state the product number and the serial number of your pump when you contact Grindex, see [Product Description](#) (page 10).

The pump delivers too little or no water



WARNING:

Always disconnect and lock out power before servicing to prevent unexpected startup. Failure to do so could result in death or serious injury.

NOTICE:

Do NOT override the motor protection repeatedly if it has tripped. Doing so may result in equipment damage.

Cause	Remedy
The impeller rotates in the wrong direction.	<ul style="list-style-type: none"> • If it is a 3-phase pump without SMART™, transpose two phase leads. For pumps with softstarter, transpose the leads at T1, T2, T3 on the softstarter. • If it is a 3-phase pump with SMART™, correct the internal wiring. • If it is a 1-phase pump: Contact the local Grindex service shop.
One or more of the valves are set in the wrong positions.	<ul style="list-style-type: none"> • Reset the valves that are set in the wrong position. • Replace the valves, if necessary. • Check that all valves are correctly installed according to media flow. • Check that all valves open correctly.
The impeller is difficult to rotate by hand.	<ul style="list-style-type: none"> • Clean the impeller. • Clean out the sump. • Check that the impeller is properly trimmed.
The pipes are obstructed.	Clean out the pipes to ensure a free flow.
The pipes and joints leak.	Find the leaks and seal them.
There are signs of wear on the impeller, pump, and casing.	Replace the worn parts.
The liquid level is too low.	<ul style="list-style-type: none"> • Check that the level sensor is set correctly. • Depending on the installation type, add a means for priming the pump, such as a foot valve.

If the problem persists, contact the local Grindex service shop. Always state the product number and the serial number of your pump when you contact Grindex, see [Product Description](#) (page 10).

The pump does not start when a softstarter is used

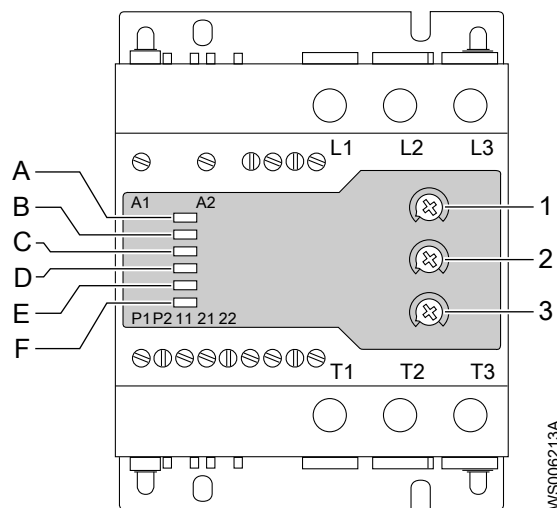

Figure 8: Softstarter terminal layout

For typical use of the pump in any application, use default settings. If a more powerful or smoother start is required, the potentiometers can be set as described in the table.

Potentiometer	Function	More powerful start	Smoother start
1	Ramp up time [Ramp U]	Lower than default	Higher than default
2	Ramp down time [Ramp D]	N/A	N/A
3	Initial torque [Torque]	Higher than default	Lower than default

LED	Status	Alarm signal
A	Power supply on	Green, continuous
B	Ramping	Yellow, intermittent
C	Bypass relay ON	Yellow, continuous
D	Softstarter over-temperature protection stops pump	Red, intermittent
	Motor protection stops pump	Red, continuous
E	L3 phase loss before pump starts (detection is made during power up of the device and thereafter it is deactivated)	Red, fast intermittent
E	Phase loss and/or low voltage alarm	Red, slow intermittent
F	Incorrect phase sequence (detection is made during power up of the device and thereafter it is deactivated)	Red, intermittent



WARNING:

Always disconnect and lock out power before servicing to prevent unexpected startup. Failure to do so could result in death or serious injury.

NOTICE:

Do NOT override the motor protection repeatedly if it has tripped. Doing so may result in equipment damage.

Always reset the softstarter by switching the power of and on again and make sure other possible problems described in [Troubleshooting](#) (page 46) have been ruled out before performing the steps below:

1. Disconnect and lock out power.
2. Make sure there is a safety distance of at least 20 m (65 ft.) between the product and the pumped or mixed liquid.
3. Remove the top cover.
4. Reconnect power and note the type of alarm signal.
5. Disconnect and lock out power.
6. Perform the remedy for the noted type of alarm signal.
7. Reconnect power to verify that the problem has been resolved.
Repeat steps 5-7 until the problem has been resolved.

Cause	Remedy
LED A is OFF.	Check: <ul style="list-style-type: none"> • The power cable and its connections to L1, L2, L3 (internal power supply is connected to L1, L2). • Fuses, contactors, switches and motor protection devices. • That line voltage is not too low.
LED A is ON.	Check: <ul style="list-style-type: none"> • The connection of the stator leads to T1, T2, T3. • The control input connections to A1, A2.
LED D is ON intermittently.	<ol style="list-style-type: none"> 1. Allow the pump to cool down. 2. Check that the number of starts per hour does not exceed the specified level. Refer to <i>Motor data</i> (page 54).
LED D is ON continuously.	<ol style="list-style-type: none"> 1. Allow the pump to cool down. 2. Check: <ol style="list-style-type: none"> a. The main fuses. b. That the rated current has been set on the motor protection device. c. That line voltage is not too low. d. That the power cable is not too long so that it causes low voltage. e. If the impeller is clogged.
LED E is ON.	Check the power cable connections to L3. If either L1 or L2 is missing, then LED A and LED E will be OFF.
LED F is ON.	Transpose two phase leads for L1, L2, L3 outside the pump.

If the problem persists, contact the local Grindex service shop. Always state the product number and the serial number of your pump when you contact Grindex, see *Product Description* (page 10).

Technical Reference

Application limits

Data	Description
Media (liquid) temperature	Maximum temperature 40°C (104°F)
pH of the pumped media (liquid)	5–8
Media (liquid) density	Maximum density: 1100 kg/m ³ (9.2 lb. per US gal.)
Depth of immersion	20 m (65 ft.)
Other	For specific weight, current, voltage, power rating, and speed of the pump, see the data plate on the pump. For starting current, see Motor data (page 54). For other applications, contact the nearest Grindex representative for information.

Motor data

Feature	Description
Motor type	Squirrel-cage induction motor
Frequency	Standard version: 50 or 60 Hz MSHA version: 60 Hz
Supply	3-phase
Starting method	<ul style="list-style-type: none"> • Direct on-line • Internal star-delta • Internal soft starter
Maximum starts per hour	30 evenly spaced starts per hour
Code compliance	IEC 60034-1
Rated output variation	±10%
Voltage variation without overheating	±10%, provided that it does not run continuously at full load
Voltage imbalance tolerance	2%
Maximum frequency variation (for pumps with SMART™)	±3 Hz
Stator insulation class	H (180°C [360°F])

Specific motor data, standard version

3-phase, 50 Hz

Motor type:

- 2,855 rpm
- Rated output 10 kW (13.4 hp)
- Maximum power consumption 11.7 kW (15.7 hp)

Voltage, V	Rated Current, A	Starting current, A	Power factor, cos Φ
220 D	34	195	0.91
230 D	33	205	0.88
240 D	34	215	0.83
380 D	20	124	0.88
400 D	21	132	0.81
415 D	18	111	0.89
440 D	18	119	0.83
500 D	15	94	0.88
525 D	14	80	0.91
550 D	14	84	0.88
660 Y	12	72	0.87
690 Y	12	76	0.82
1000 Y	8	51	0.84

3-phase, 60 Hz

Motor type:

- 3,465 rpm
- Rated output 11.2 kW (15 hp)
- Maximum power consumption 12.8 kW (17.2 hp)

Voltage, V	Rated Current, A	Starting current, A	Power factor, cos Φ
200 D	40	250	0.92
208 D	39	262	0.9
220 D	37	222	0.93
220 Y parallel	37	213	0.92
220 D parallel	37	222	0.92
230 D	35	233	0.91
230 Y parallel	35	224	0.91
230 D parallel	36	233	0.9
240 D	35	245	0.88
240 Y parallel	35	235	0.88
380 D	21	128	0.93
380 Y parallel	21	128	0.93

Voltage , V	Rated Current, A	Starting current, A	Power factor, cos φ
400 D	20	136	0.9
400 Y parallel	21	135	0.9
440 D	19	129	0.89
440 D serial	18	111	0.92
440 Y serial	18	107	0.92
460 D	19	135	0.84
460 D serial	18	117	0.91
460 Y serial	18	112	0.91
480 D	20	142	0.79
480 Y serial	17	117	0.88
575 D	14	96	0.9
600 D	14	101	0.87

Specific motor data, MSHA version

3-phase, 60 Hz

Motor type:

- 3,455 rpm
- Rated output 11.2 kW (15 hp)
- Maximum power consumption 13 kW

Voltage (V)	Rated current (A)	Starting current (A)
460 Y	17	109
480 Y	17	114
575 Y	14	91
600 Y	14	95

Dimensions and weights

All measurements in the illustrations are in millimeters, if not otherwise specified.

Standard version

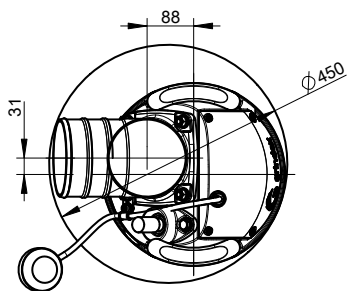
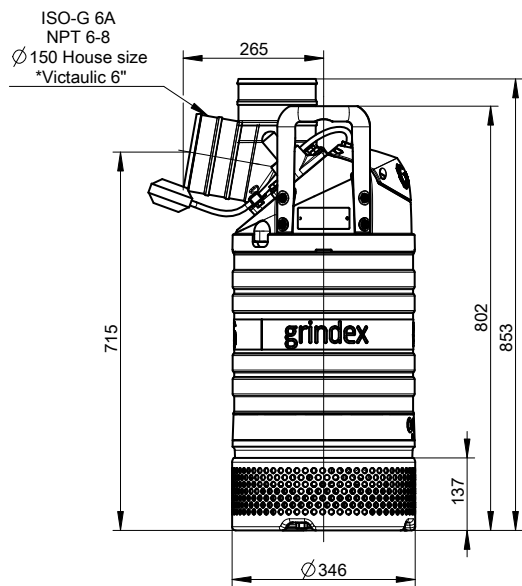

*Designed for "Victaulic Coupling, according to ANSI/AWWA C606-97
SCREEN OPENING Ø10

Weight (kg)	
Total	80

WS006739A

Figure 9: N, DN 150

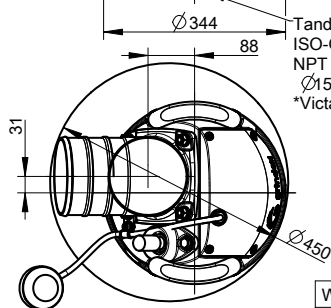
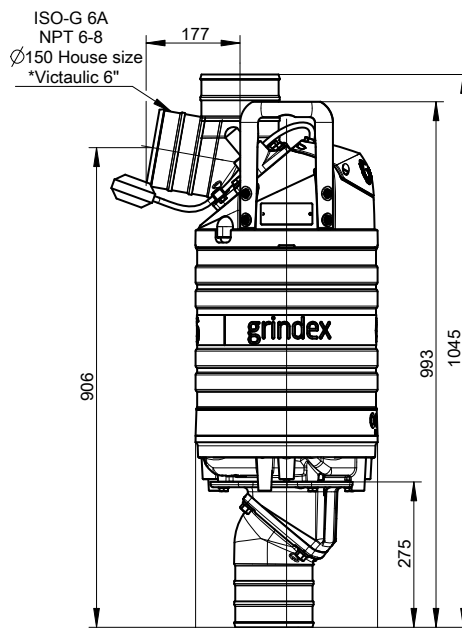

*Designed for "Victaulic Coupling, according to ANSI/AWWA C606-97

Weight (kg)	
Total	82

WS0067846A

Figure 10: N, DN 150, tandem

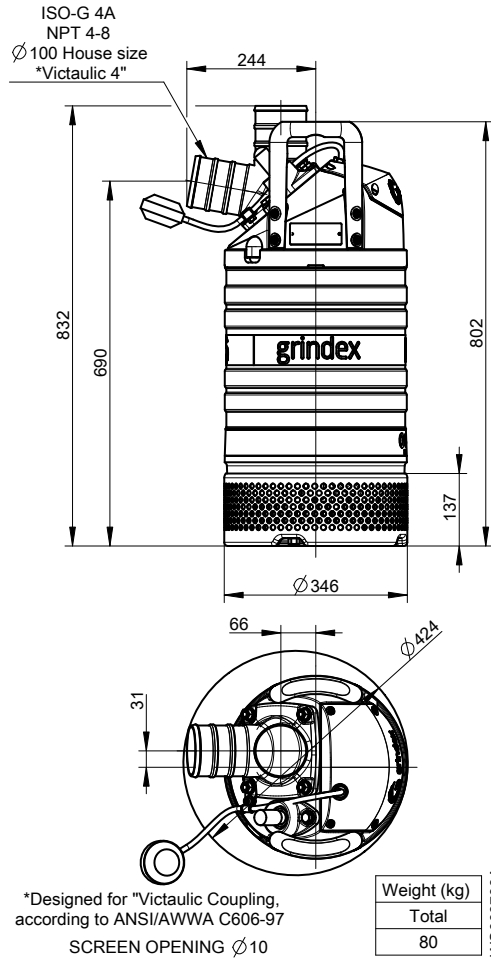

Figure 11: H, DN 100

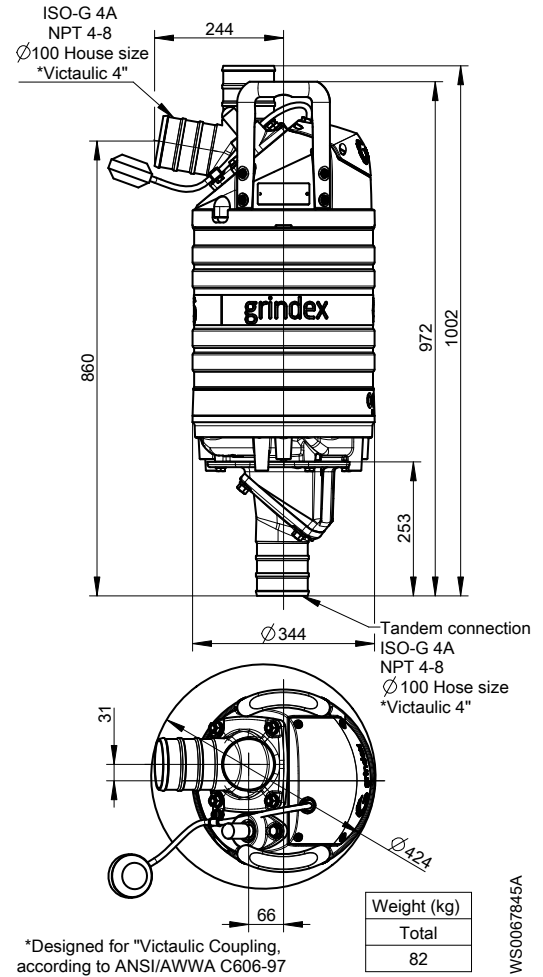
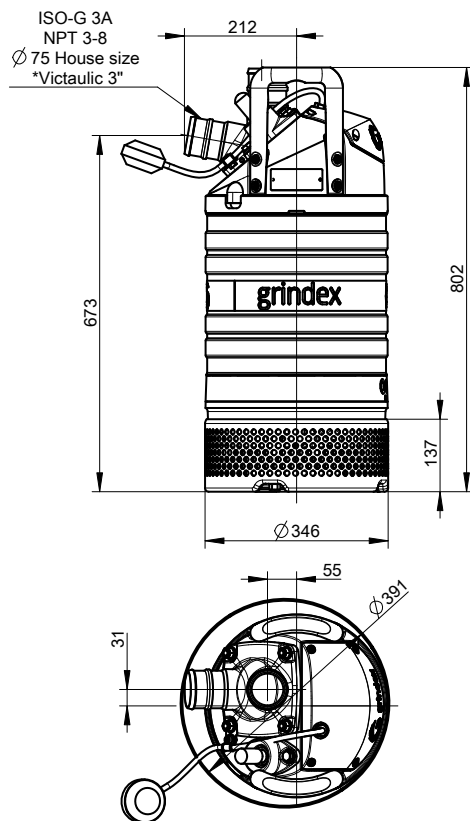

Figure 12: H, DN 100, tandem



*Designed for "Victaulic Coupling, according to ANSI/AWWA C606-97

SCREEN OPENING $\varnothing 10$

Weight (kg)
Total
80

WS006737A

Figure 13: H, DN 75

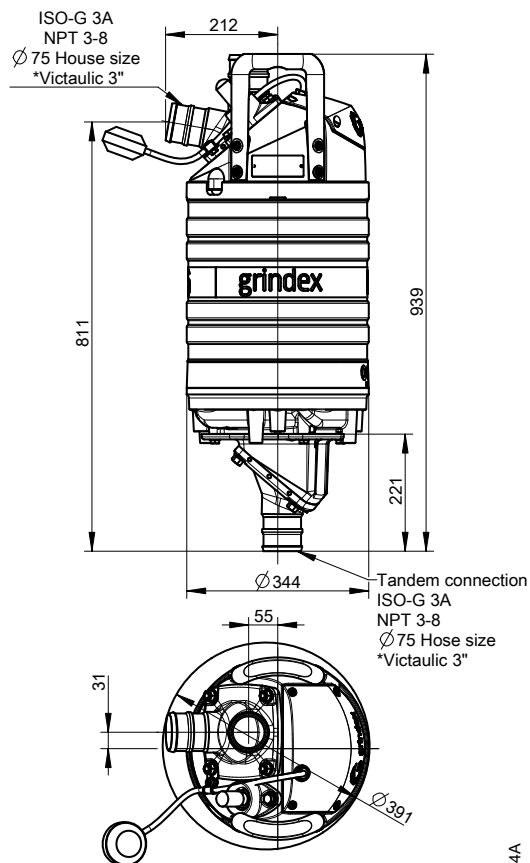

*Designed for "Victaulic Coupling, according to ANSI/AWWA C606-97

Weight (kg)
Total
82

WS0067844A

Figure 14: H, DN 75, tandem

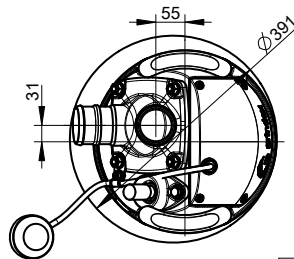
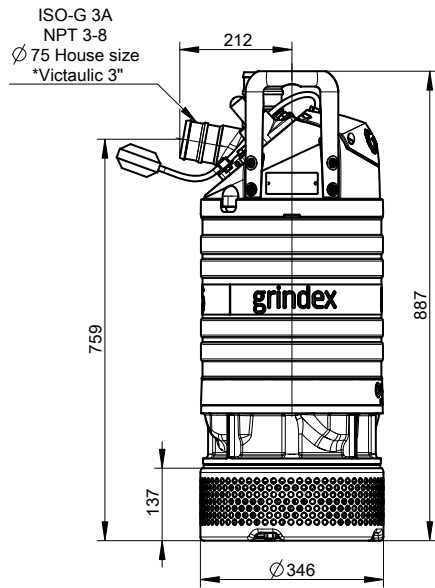

*Designed for "Victaulic Coupling, according to ANSI/AWWA C606-97 SCREEN OPENING Ø10

Weight (kg)
Total
98

WS006740A

Figure 15: SH, DN 75

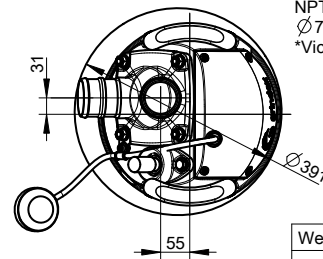
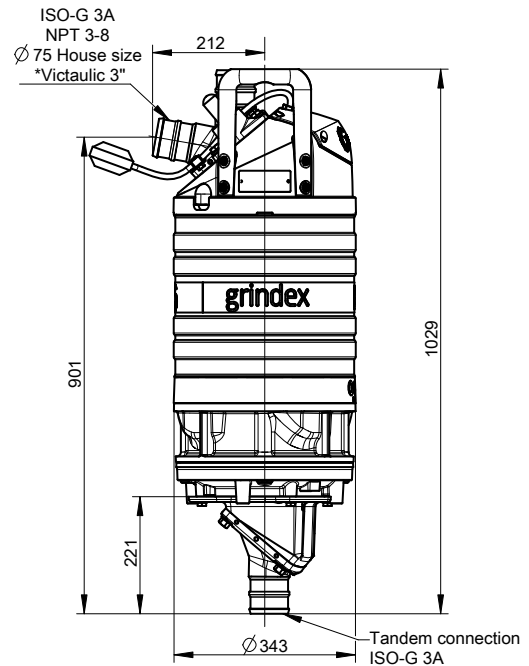

*Designed for "Victaulic Coupling, according to ANSI/AWWA C606-97

Weight (kg)
Total
100

WS006742A

Figure 16: SH, DN 75, tandem

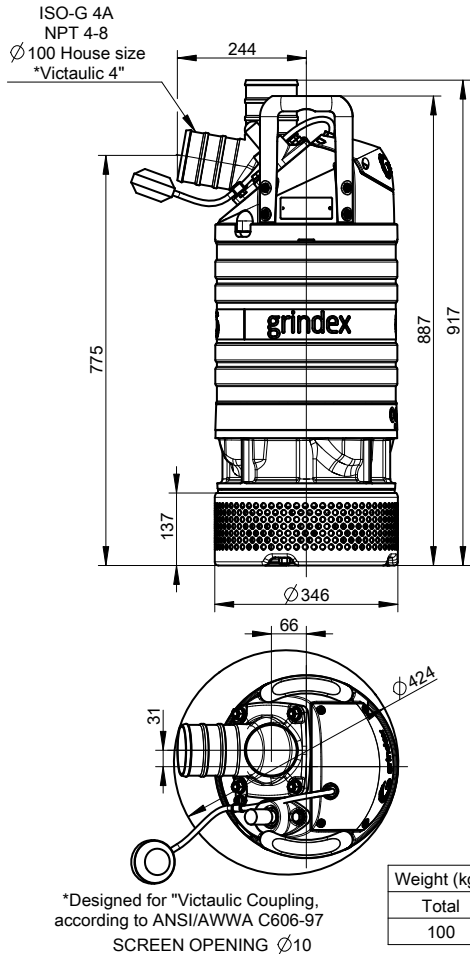

Figure 17: SH, DN 100

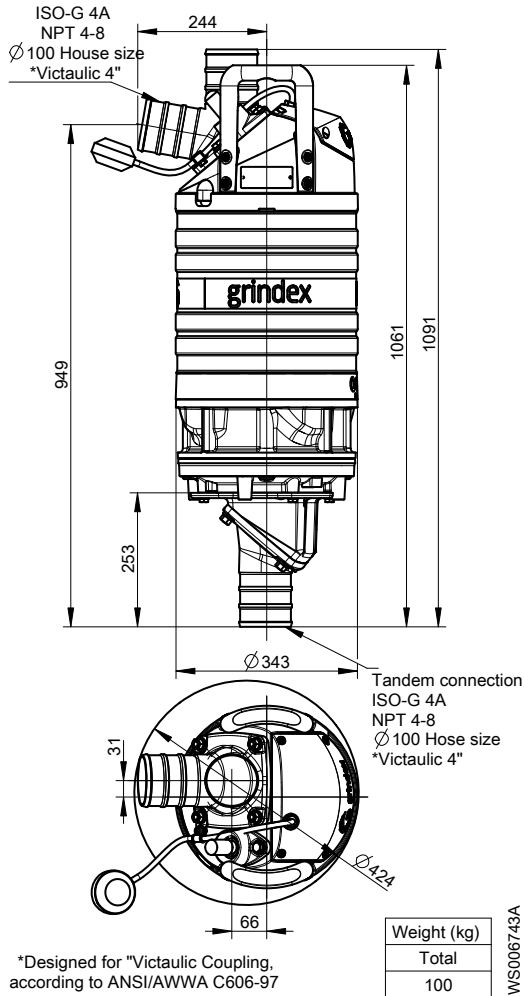

Figure 18: SH, DN 100, tandem

MSHA version

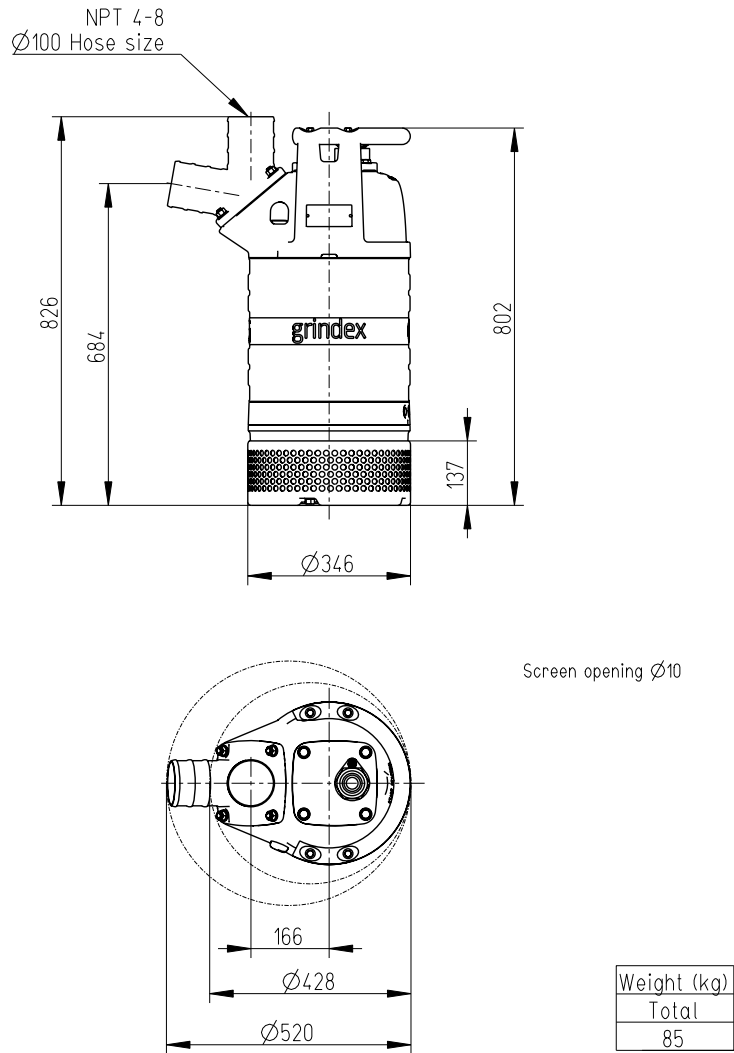
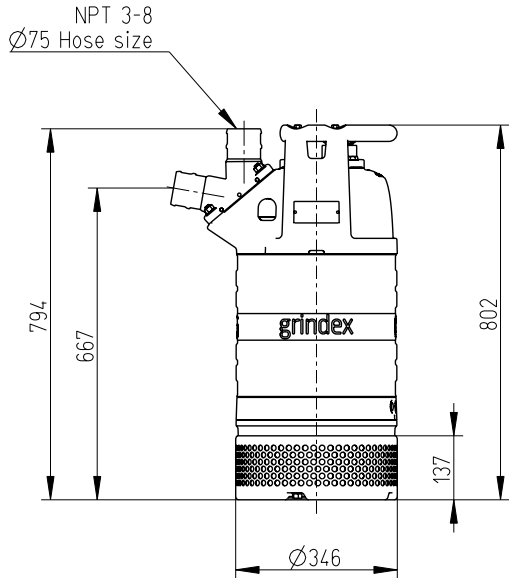
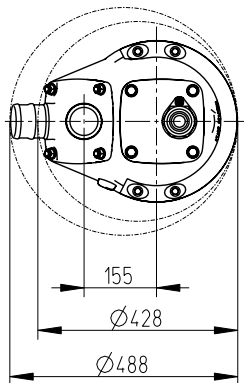

Figure 19: MSHA version, N



Screen opening Ø10



Weight (kg)
Total
85

Figure 20: MSHA version, H

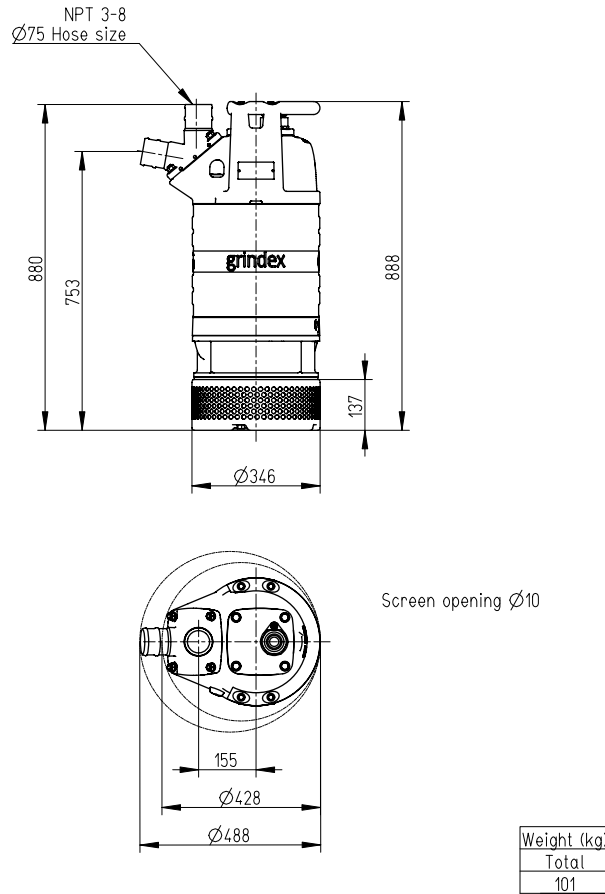

Figure 21: MSHA version, SH

Performance curves

Test standard

Pumps are tested in accordance with ISO 9906:2012, HI 11.6:2012.

Standard pump version, 50 Hz

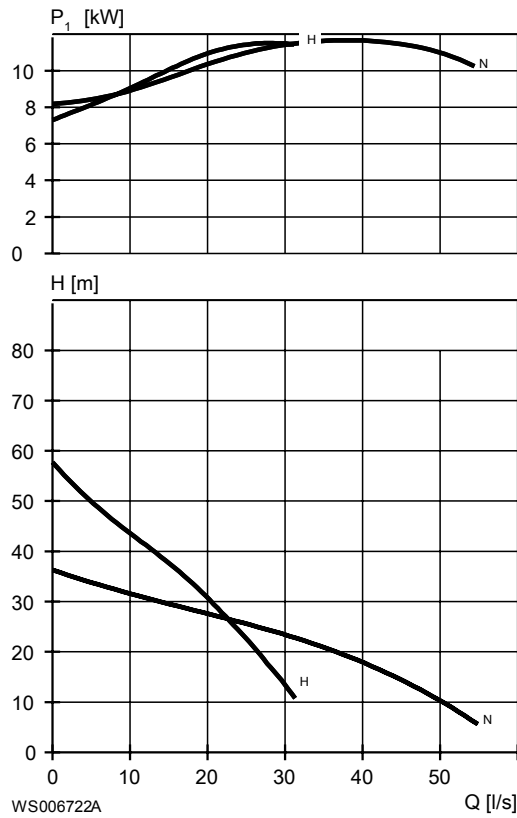

Figure 22: N, H

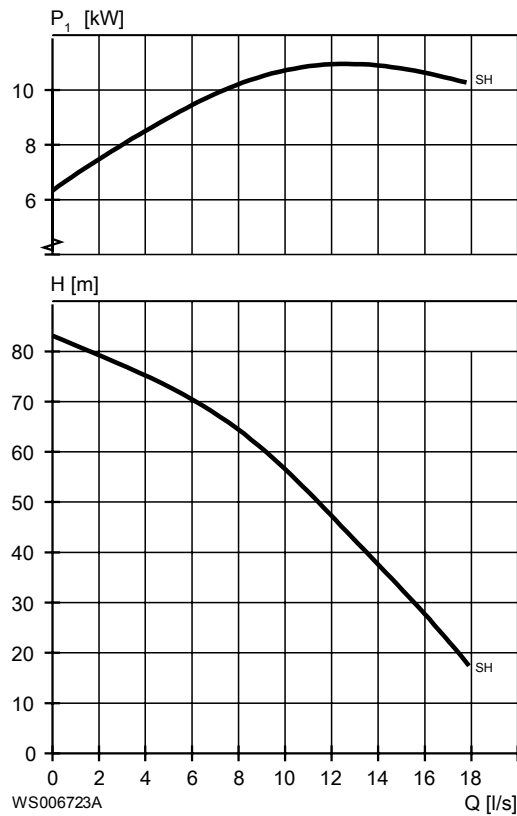

Figure 23: SH

Standard pump version, 60 Hz

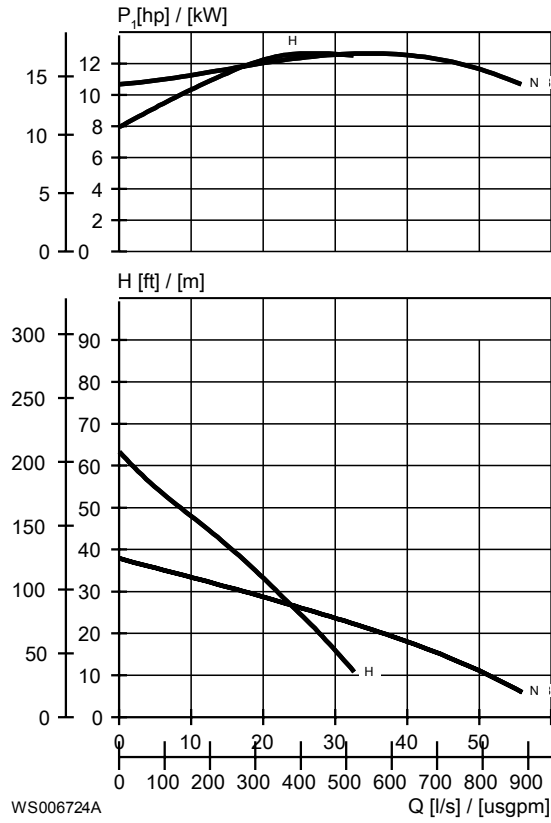

Figure 24: N, H

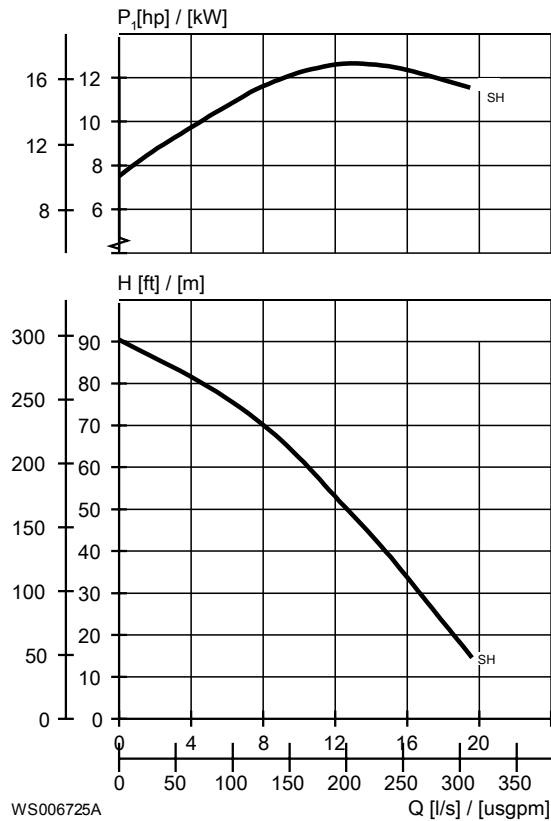

Figure 25: SH

MSHA pump version, 60 Hz

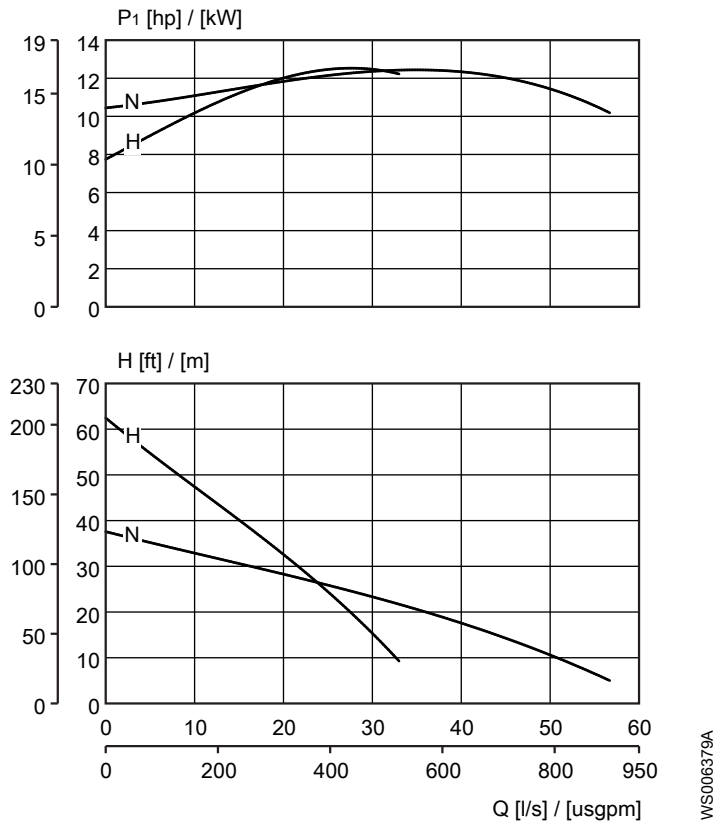

Figure 26: N, H

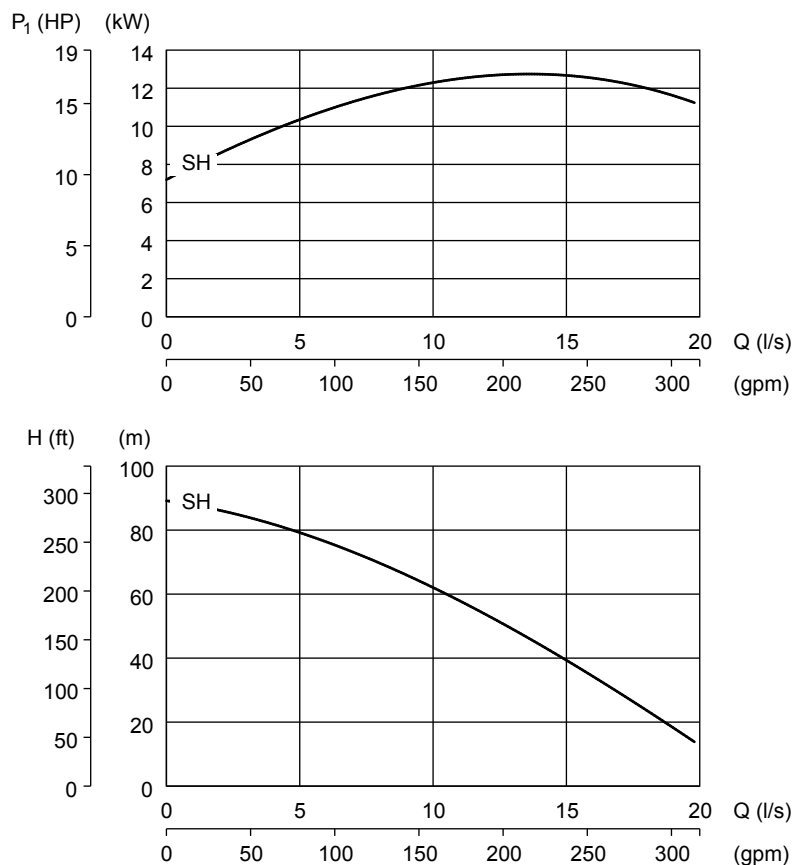

Figure 27: SH



Grindex
Gesällvägen 33
174 87 Sundbyberg
Sweden
Tel: +46-8-606 66 00
Fax: +46-8-745 53 28
www.grindex.com

Visit our Web site for the latest version of this document
and more information

The original instruction is in English. All non-English
instructions are translations of the original instruction.

© 2012 Grindex