

Parts List

Bravo 600 — 8150.020/.190



www.grindex.com



Parts List

Bravo 600 — 8150.020/190

Overview

Table of Contents

This publication contains the following topics:

Topic

Introduction	4
Practical Information	5
Data Plate Interpretation.....	6
Order parts.....	7
Motor Parts	8
Non Explosion-proof	9
Explosion-proof.....	11
List.....	13
Hydraulic Parts.....	18
Without Agitator	19
With Agitator.....	20
List.....	21

Introduction

Purpose

The purpose of this manual is to give the reader information about available spare parts and accessories for the product.

Recipient

The manual is principally intended for Grindex

- customers
 - service personnel
 - sales personnel
-

Contact

For more information

- contact your Grindex representative
 - visit <http://www.grindex.com/>
-

Reference

More information about the product is available in the following documents:

- Installation, Operation and Maintenance
 - Grindex accessories list
-

Practical Information

Overview

Table of Contents

This chapter contains the following topics:

Topic	
Data Plate Interpretation	6
Data Plate.....	6
Order parts	7

Data Plate Interpretation

Introduction

The Grindex product is always provided with data plates:

- The general data plate is used on all products.
- The approval plate is added to all explosion proof products.

Data Plate

The product may only be operated within the parameters stated on the data plate.

Illustration

This is an illustration of a general data plate.

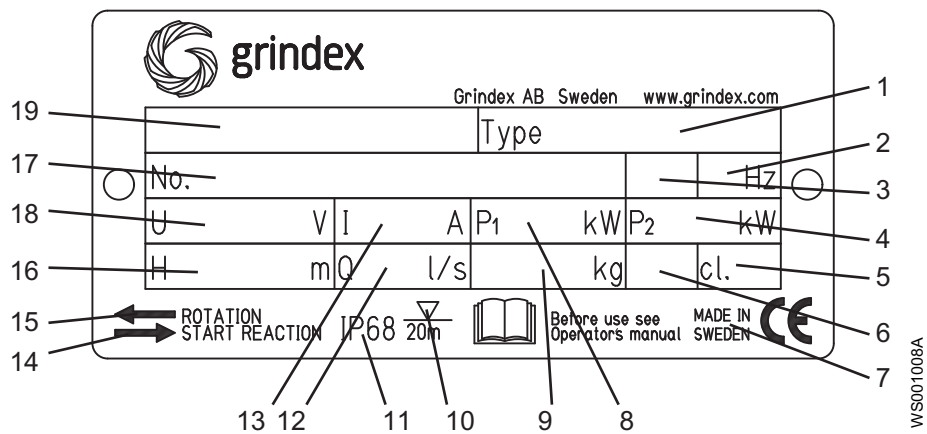

Field description

This table shows the fields on the general data plate, and which information each field contains.

Field	Description	Field	Description
1	Pump type number	11	Degree of protection
2	Frequency	12	Maximum capacity
3	Phases, type of current	13	Rated current
4	Rated shaft power	14	Direction of the start reaction
5	Thermal class	15	Direction of the impeller rotation
6	Locked rotor code-letter	16	Maximum head
7	Country of origin	17	Serial number
8	Maximum power consumption	18	Rated voltage
9	Product weight	19	Pump model
10	Maximum submersion depth	-	-

Order parts

Order

When ordering spare parts, state product number and serial number of the product, spare part number and quantity.

Requirements

Genuine Grindex parts must always be used for repairs if the product is to fulfill requirements and obtain official approval.

Specially Approved Products

Spare parts marked with ^(EX) after the part number are subject to dimensional accuracy inspection.

Motor Parts

Overview

Table of Contents

This chapter contains the following topics:

Topic	
Non Explosion-proof	9
Without Cooling Jacket	9
With Cooling Jacket	10
Explosion-proof	11
Without Cooling Jacket	11
With Cooling Jacket	12
List	13

Non Explosion-proof

Without Cooling Jacket

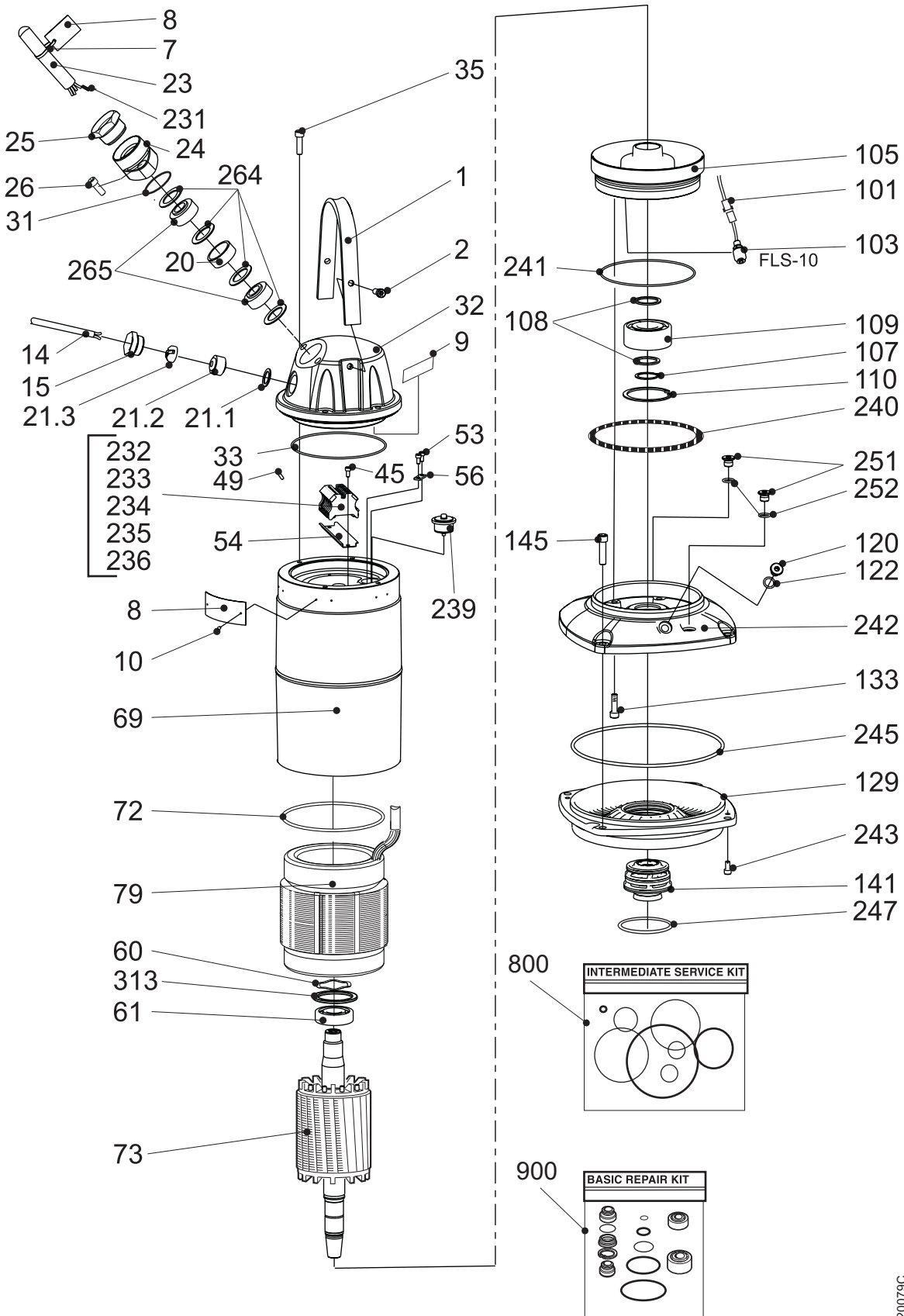

20079C

With Cooling Jacket

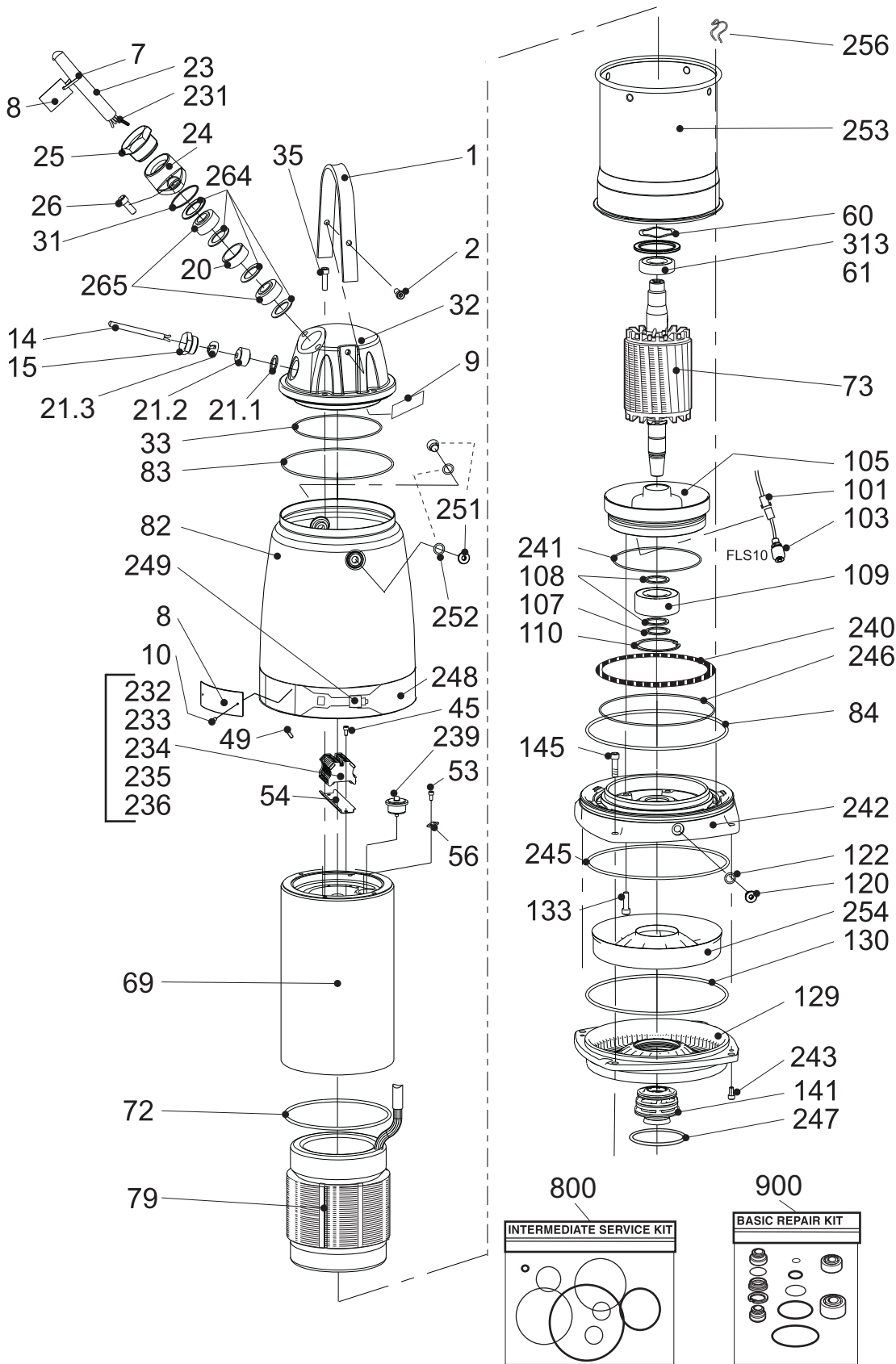

20092B

Explosion-proof

Without Cooling Jacket

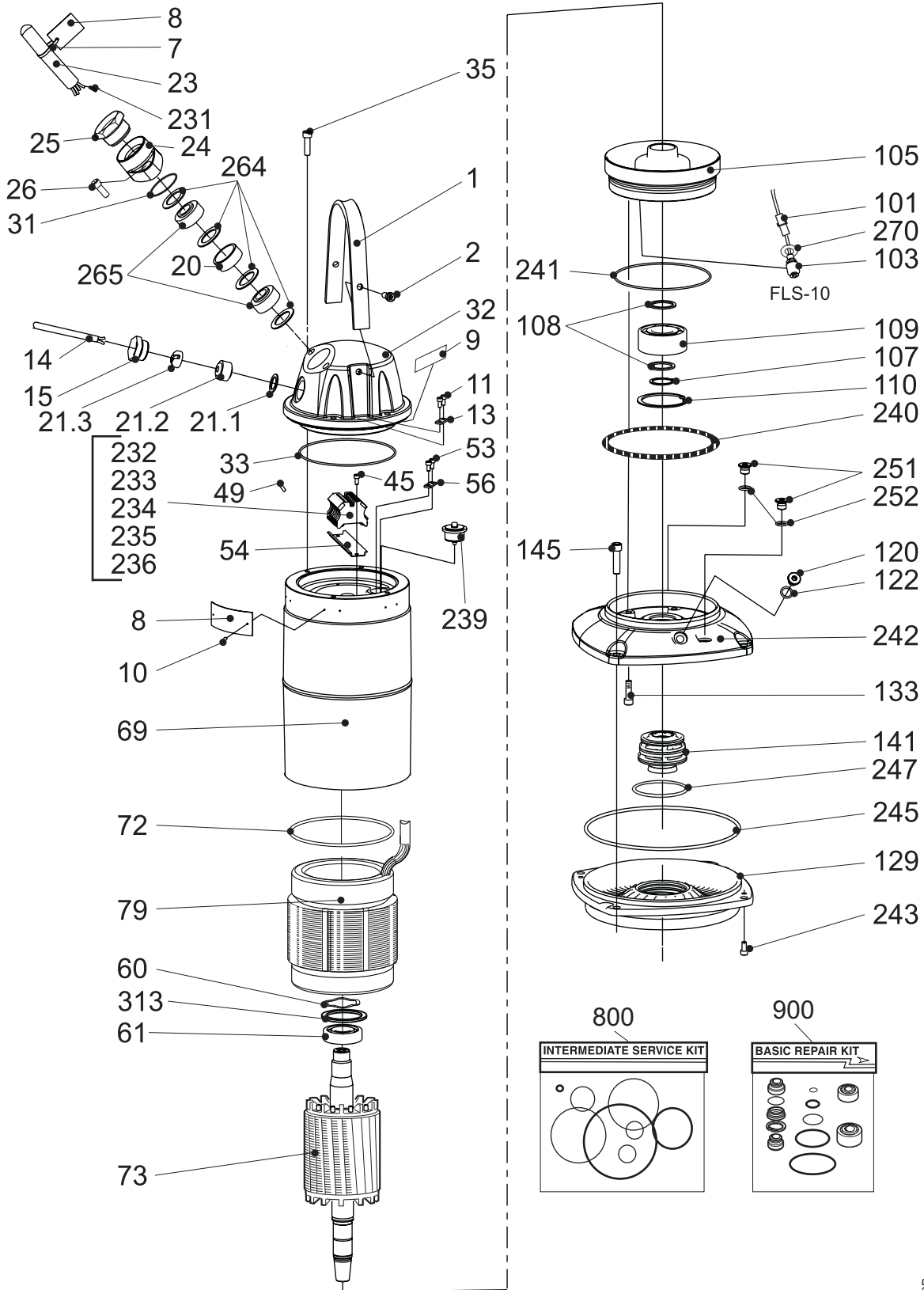

20093B

With Cooling Jacket

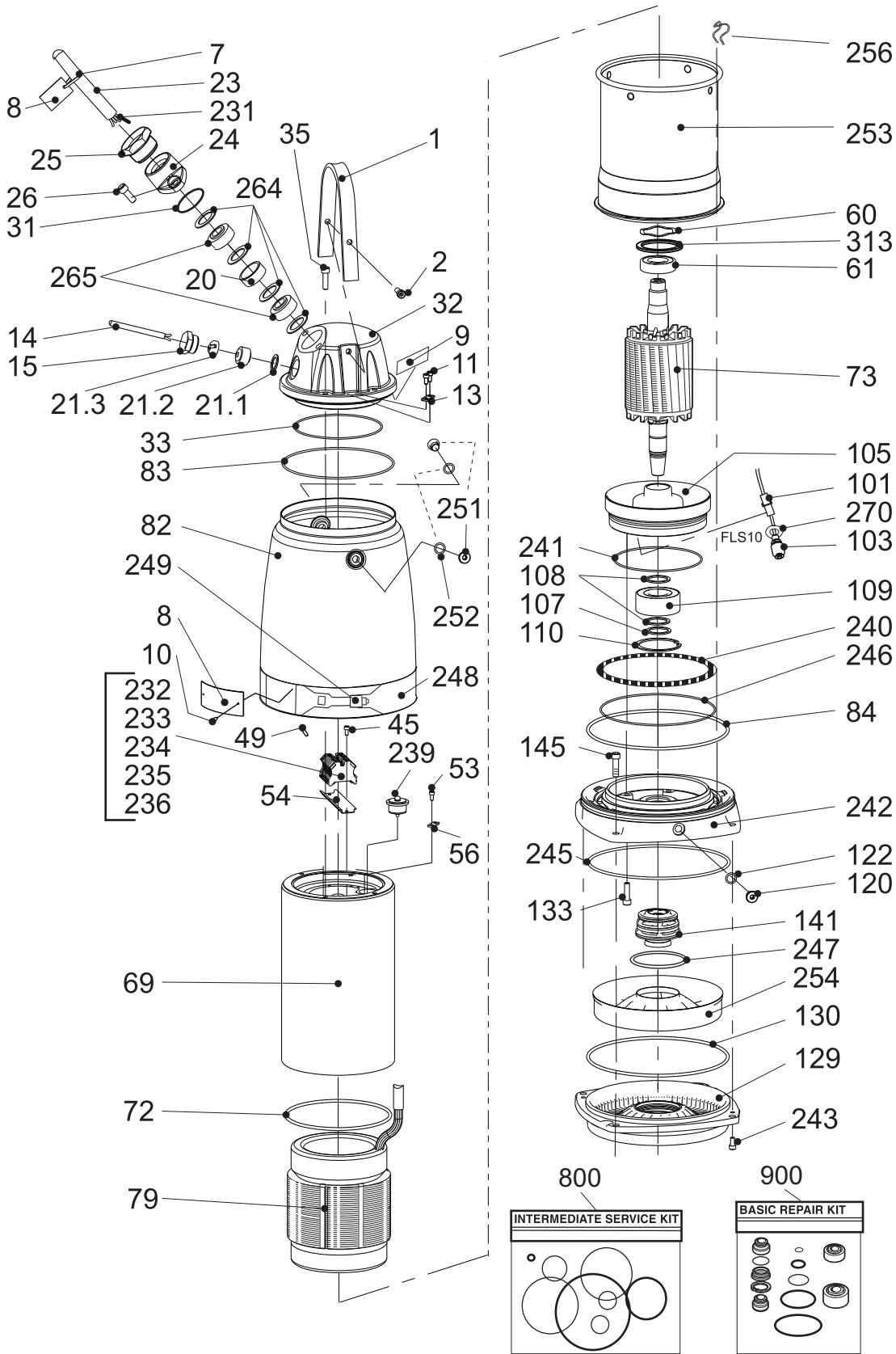

20094B

List

Pos. No	Part. No	Denomination	Qty/Version	
			020	190
1	51 465 00	Lifting handle	1	1
2	410 374	Hex.socket hd screw M12X45-A4-80 ITT Part. No 83 04 53	2	2
7	410 517	Cable tie 200X2.4 PA 6/6 -55+105	1	1
7	50 457 02	Cable tie 292X3.5;NYLON;+125 C	1	1
8	51 648 00	Certificate plate ITT Part. No 630 69 02		2
8	50 888 00	Plate-blank Use 50 907 00 (EU), 50 907 01 (US) as spare part for non explosion-proof version.	1	1
8	50 888 00	Plate-blank Use 51 633 00 (EU), 51 633 02 (US) as spare part for explosion-proof version. ITT Part. No 763 58 00 and 763 58 01 resp.	1	1
8	51 614 00	Certificate plate ITT Part. No 752 20 00		1
9	410 526	Marking strip 5-GW(T1;T2;T15;T16)	1	1
9	410 527	Marking strip W5;V5;U5;V2;W1;U2;V1;W2;U	1	1
9	50 918 00	Connection plate SCREENED CABLE	1	1
9	51 426 00	Connection plate	1	1
9	51 438 00	Plate	1	1
9	51 440 00	Connection plate	1	1
9	51 441 00	Connection plate	1	1
10	410 000	Drive screw 4X5-A2-70 ITT Part. No 82 20 88	4	6
11	410 503	Hex.socket hd screw M6X12-A2-70 ITT Part. No 82 00 11		2
13	50 902 00	Earthing plate		1
14	410 350	Control cable SUBCAB 7X1.5 MM2 OD=15-17	*	*
15	51 407 00	Gland screw FOR CABLE ENTRY ITT Part. No 397 81 00	1	1
20	51 025 02	Ring	1	1
21.1	50 127 04	Plain washer (10)-22 MM	1	1
21.2	410 043	Seal sleeve (10)-12 MM	1	1
21.2	410 045	Seal sleeve (14)-16 MM	1	1
21.3	50 926 00	Cable clip (10)-12 MM	1	1
21.3	50 926 02	Cable clip (14)-16 MM	1	1
23	410 061	Motor cable SCREEN S3X2.5+3X2.5/3+4X1	*	*
23	410 063	Motor cable 7G2.5+2X1.5 MM2 OD=20-23	*	*
23	410 068	Motor cable 12AWG/7 OD=20-22 MM	*	*

Pos. No	Part. No	Denomination	Qty/Version	
			020	190
23	410 069	Motor cable 10AWG/3-2-1-GC OD=20-22MM	*	*
23	410 124	Motor cable SCREEN S3X6+3X6/3+4X1.5	*	*
23	410 126	Motor cable 4G6+2X1.5 MM2 OD=23-25 MM	*	*
23	410 127	Motor cable 4G10+2X1.5 MM2 OD=26-28MM	*	*
23	410 128	Motor cable 4G16+2X1.5 MM2 OD=26-28MM	*	*
23	410 129	Motor cable 4G4+2X1.5 MM2 OD=20-22 MM	*	*
23	410 130	Motor cable 7G4+2X1.5 MM2 OD=22-26 MM	*	*
23	410 131	Motor cable 7G6+2X1.5 MM2 OD=24-28 MM	*	*
23	410 134	Motor cable 8AWG/3-2-1-GC OD=27-29 MM	*	*
23	410 135	Motor cable 6AWG/3-2-1-GC OD=30-32 MM	*	*
23	410 136	Motor cable 4AWG/3-2-1-GC OD=33-35 MM	*	*
23	410 347	Motor cable SUBCAB S3X16+3X16/3+4X1.5	*	*
23	50 777 00	Motor cable 4G2.5+2X1.5 MM2 OD=17-18	*	*
24	51 411 00 (EX)	Entrance flange SS	ITT Part. No 597 87 01	1 1
24	51 411 01 (EX)	Entrance flange ISO 228/1-G2	ITT Part. No 597 87 04	1 1
24	51 411 02 (EX)	Entrance flange 2-11.5 NPT	ITT Part. No 597 87 08	1 1
24	51 411 03 (EX)	Entrance flange 1 1/2-11.5 NPT	ITT Part. No 597 87 11	1 1
24	51 423 00 (EX)	Entrance flange	ITT Part. No 642 17 01	1 1
25	51 419 00	Gland screw 1 1/4" ISO.FOR METALHOSE	For use with metal hose. ITT Part. No 633 11 01	1 1
25	51 419 01	Gland screw 1 1/2" NPT.FOR METALHOSE	For use with metal hose. ITT Part. No 633 11 04	1 1
26	410 374	Hex.socket hd screw M12X45-A4-80	ITT Part. No 83 04 53	2 2
31	410 086	O-ring 49.5X3 NBR		1 1
31	410 513	O-ring 49.5X3 FPM		1 1
32	51 461 00	Entrance cover		1
32	51 461 01	Entrance cover		1
32	51 461 02 (EX)	Entrance cover	ITT Part. No 650 87 03	1

Pos. No	Part. No	Denomination	Qty/Version		
			020	190	
32	51 461 03 (EX)	Entrance cover		1	
33	132 380	O-ring 194.3X5.7 NBR	1	1	
33	410 549	O-ring 194.3X5.7 FPM	1	1	
35	410 374	Hex.socket hd screw M12X45-A4-80	4	4	
45	410 503	Hex.socket hd screw M6X12-A2-70	2	2	
49	410 515	End sleeve H16/24	3	3	
49	410 516	End sleeve H25/30	3	3	
53	410 503	Hex.socket hd screw M6X12-A2-70	4	4	
54	51 464 00	Rail	1	1	
56	50 902 00	Earthing plate	2	2	
60	410 080	Spring washer 71.5X59X0.55	1	1	
61	410 100	Ball bearing 3306A-2Z/C3VT113	1	1	
69	51 463 00	Stator housing	1		
69	51 463 01 (EX)	Stator housing		1	
72	410 546	O-ring 239.5X5.7 NBR	1	1	
72	410 550	O-ring 239.3X5.7 FPM	1	1	
73	51 466 02	Shaft unit	1	1	
79	51 467 01	Stator 25-19-4a	50Hz: 660 - 690V Y, 380 - 400V D. 60Hz: 460V D.	1	1
79	51 467 02	Stator 25-19-4a	50Hz: 400V Y, 230V D.	1	1
79	51 467 05	Stator 25-19-4a	50Hz: 415 - 440V D.	1	1
79	51 467 06	Stator 25-19-4a	50Hz: 500V D. 60Hz: 575 - 600V D.	1	1
79	51 467 07	Stator 25-19-4a	60Hz: 460V Yser, 230V Y//.	1	1
79	51 467 08	Stator 25-19-4a	60Hz: 380V D.	1	1
82	51 627 00	Cooling jacket	Standard	1	1
82	51 627 01	Cooling jacket	Stainless steel	1	1
83	132 415	O-ring 259.3X5.7 NBR	1	1	
83	410 700	O-ring 259.3X5.7 FPM	1	1	
84	131 929	O-ring 339.3X5.7 NBR	1	1	
101	50 698 00	Cable unit FLS10	1	1	
103	50 486 01 (EX)	Level sensor FLS10	ITT Part. No 663 04 00	1	1
105	51 459 00	Bearing holder	1		
105	51 459 01 (EX)	Bearing holder	ITT Part. No 650 80 01		1
107	132 381	Retaining ring SGA 55	1	1	
108	132 373	Supporting washer S 55X68X3	2	2	
109	410 555	Ball bearing 3311A-2Z/C3VT113	1	1	

Pos. No	Part. No	Denomination	Qty/Version	
			020	190
110	410 554	Retaining ring 120/2,85	1	1
120	51 428 00	Plug	1	1
122	410 508	O-ring 17X3 NBR	3	3
122	410 511	O-ring 17X3 FPM	3	3
129	51 458 00	Seal housing cover	1	1
130	410 699	O-ring 290X3 NBR	2	2
133	410 374	Hex.socket hd screw M12X45-A4-80 ITT Part. No 83 04 53	6	6
141	51 455 00	Mechanical seal	1	1
145	410 553	Hex.socket hd screw M16X60-A4-80 ITT Part. No 83 04 58	4	4
231	410 054	Shrink hose ID 6.4	*	*
231	410 122	Shrink hose ID 9.5	*	*
232	410 523	Terminal clamp WDU6/10	3	3
233	410 519	Terminal clamp WDU35/IK/ZA	8	8
233	410 524	Terminal clamp WDU16,1000V	6	6
234	410 520	Cross connection WQW35/2	4	4
234	410 525	Cross connection WQV16/2	3	3
234	51 427 00	Cross connection	1	1
235	410 522	End support WEW 35/2	2	2
236	410 521	Partition	1	1
239	51 460 00	El.lead through unit	1	1
240	51 413 01 (EX)	Spring ITT Part. No 607 48 04	1	1
241	132 422	O-ring 219.3X5.7 NBR	1	1
241	410 547	O-ring 219.3X5.7 FPM	1	1
242	51 462 00	adapter	1	
242	51 462 01 (EX)	adapter ITT Part. No 650 89 01		1
242	51 626 00 (EX)	adapter ITT Part. No 650 88 11		1
242	51 626 01	adapter	1	
243	50 023 09	Hex.socket hd screw M12X25-A4-80 ITT Part. No 83 04 61	2	2
245	131 929	O-ring 339.3X5.7 NBR	1	1
245	410 548	O-ring 339.3X5.7 FPM	3	3
247	410 551	O-ring 92X4 FPM	1	1
248	51 611 01	Strip	1	1
249	410 719	Clip	1	1
251	51 428 00	Plug	2	2
252	410 508	O-ring 17X3 NBR	2	2
252	410 511	O-ring 17X3 FPM	2	2
253	51 629 00	Cooling jacket "INNER"	1	1

Pos. No	Part. No	Denomination	Qty/Version	
			020	190
254	51 630 00	Flow diffusor	1	1
256	51 612 00	Wire bow	4	4
264	132 312	Plain washer (33)-35 MM	4	4
264	132 334	Plain washer (14)-20 MM	4	4
264	132 336	Plain washer (20)-32 MM	4	4
265	410 113	Seal sleeve (17)-20 MM	2	2
265	410 114	Seal sleeve (20)-23 MM	2	2
265	410 115	Seal sleeve (23)-26 MM	2	2
265	410 116	Seal sleeve (26)-29 MM	2	2
265	410 117	Seal sleeve (29)-32 MM	2	2
265	410 118	Seal sleeve (32)-35 MM	2	2
270	51 118 00	Lock washer		1
313	410 084	O-ring 71.2X3 FPM	1	1
800	410 696	O-ring kit	1	1
900	51 619 02	Basic repair kit	1	1

* piece goods

Hydraulic Parts

Overview

Table of Contents

This chapter contains the following topics:

Topic

Without Agitator	19
With Agitator	20
List.....	21

Without Agitator

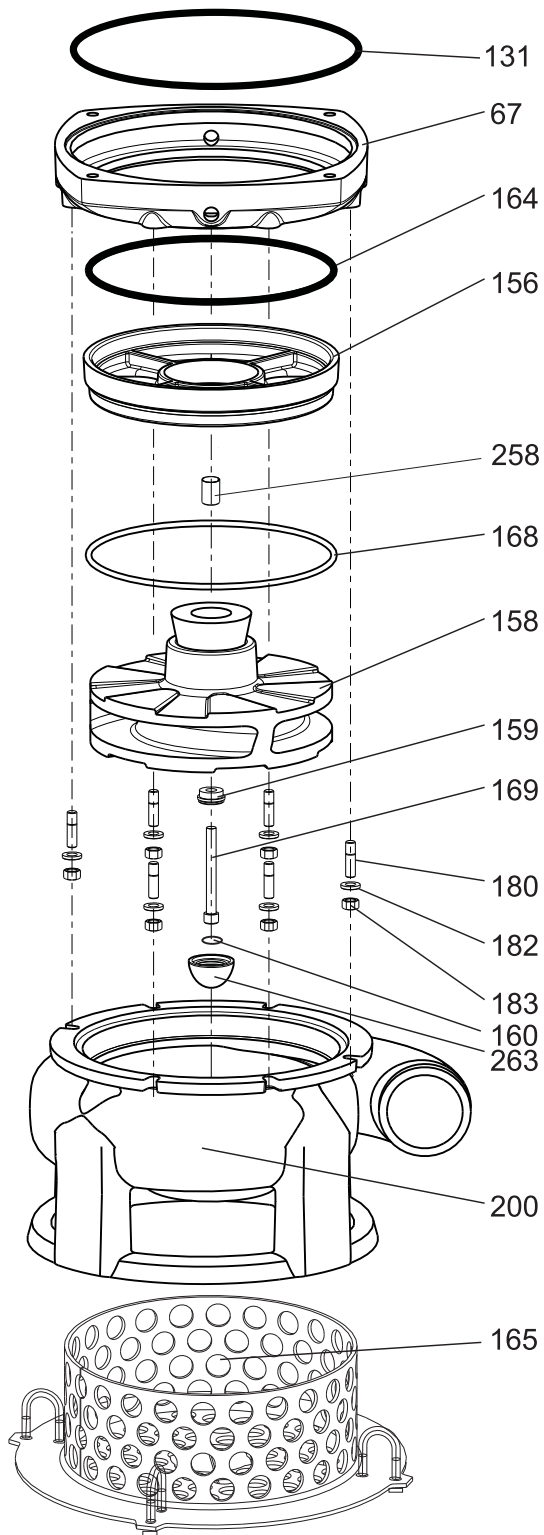

20080A

With Agitator

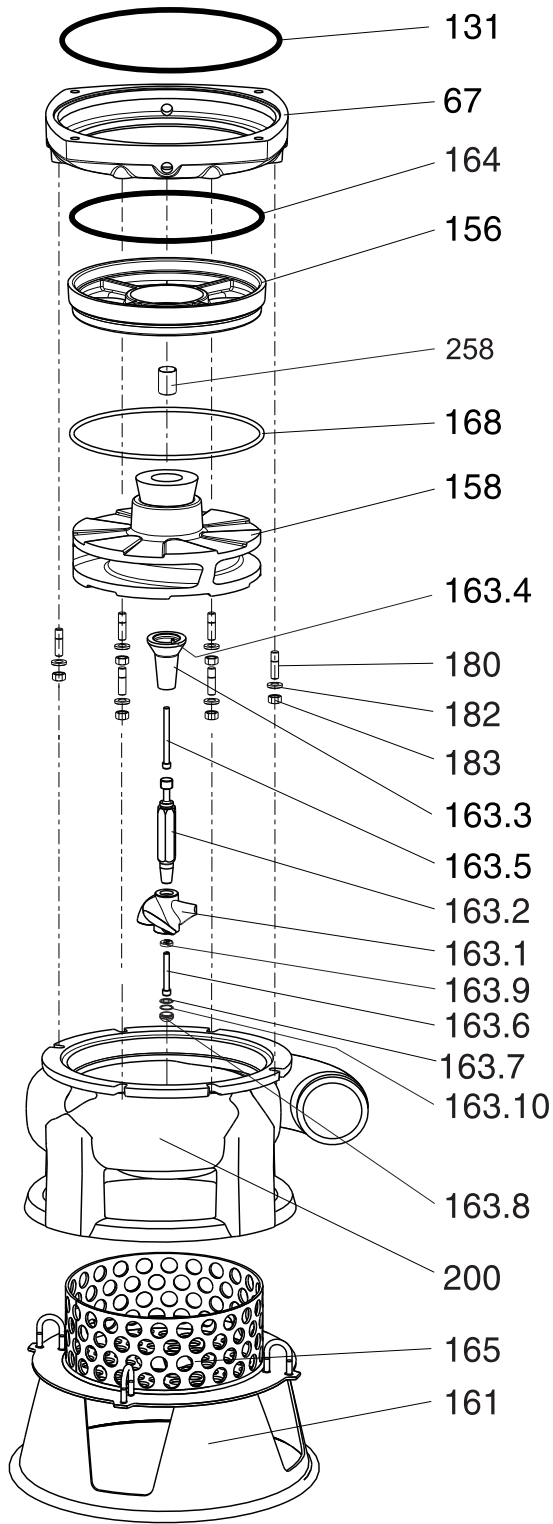

20081A

List

Pos. No	Part. No	Denomination	Qty/Version	
			020	190
67	51 598 00	Pump housing adapter	1	1
131	131 929	O-ring 339.3X5.7 NBR	1	1
156	51 425 00	Wearing cover	1	1
158	51 601 00	Impeller unit 50Hz.	1	1
158	51 601 01	Impeller unit 60Hz.	1	1
159	51 453 00	Sleeve	1	1
160	410 663	Protective plug	1	1
161	51 431 00	Stand compl.	1	1
163	51 436 02	Agitator unit	1	1
164	410 510	O-ring	1	1
165	51 433 00	Strainer compl.	1	1
168	410 509	O-ring 297,8X6,99 NITRIL	1	1
169	410 552	Hex.socket hd screw ITT Part. No 83 02 68	1	1
180	410 502	Stud 12X30-A4-70	6	6
182	410 504	Plain washer STAINLESS STEEL A4	6	6
183	132 280	Hexagon nut M12-A2-70	6	6
200	51 424 00	Pump housing	1	1
258	51 469 00	Sleeve unit	1	1
263	51 454 00	Wear protection	1	1



Grindex AB • Box 7025 • SE-174 07 Sundbyberg • Sweden • Tel +46 8 606 66 00 • Fax +46 8 745 53 28 • marketing@grindex.com

© Grindex AB. The original instruction is in English. All non-English instructions are translations of the original instruction.